

# INTRODUCTION

# 1. Introduction

1.1	Aims of this Manual .....	3
1.2	The Role of the Architect/Consultant .....	4
1.3	The Pre-Engineered Building Concept .....	6
1.4	The Merits of Pre-Engineered Buildings .....	7
1.5	Applications of Pre-Engineered Buildings .....	11
1.6	The Zamil Steel Organization .....	16
1.7	The Zamil Advantage .....	19
1.8	Zamil Steel Literature .....	22
1.9	Initiating a Request for Quotation .....	24
1.10	Placing and Tracking an Order .....	25

It is with great pleasure that we present you with the Zamil Steel Technical Manual for Pre-Engineered Steel Buildings, the most comprehensive such manual in the industry.

The contents of this manual encompass our entire pre-engineered steel buildings product line. Although this manual contains only our **standard** pre-engineered buildings products and details, most of these standards are flexible and can be adapted to broader and more complex limits to address the increasingly creative applications demanded by today's architects and designers.

### Aims of this Manual

We have developed this Manual with the following aims:

- To use as a technical orientation guide and a training tool to acquaint engineers and architects with pre-engineered steel buildings in general.
- To make available, to architects, designers and owners, the standard details of Zamil Steel pre-engineered steel buildings for the purpose of encouraging them to incorporate these details in their projects and enhance them to meet their specific requirements.
- To familiarize consultants, contractors and endusers with the operating systems of Zamil Steel and make them aware of the factors that affect our level of performance and service in the following important areas:
  - Speed of response to requests for quotation
  - Preparation of approval drawings
  - Completion of erection drawings and shop details
  - Delivery of the final building(s)
- To facilitate your interaction with Zamil Steel as we believe that the more you know about our products and our organization the easier it will

be for you to interact and communicate with us. Most of our innovative techniques have been the result of valuable feedback from our regular clientele.

### A Leader You Can Count On

Zamil Steel is recognized as the largest manufacturer of pre-engineered steel buildings in Asia and Africa. Since 1977 we have supplied over 20,000 buildings to 45 countries worldwide. Zamil Steel is continuously expanding and currently



maintains 34 Area Sales Offices located in Asia, Africa, Europe, North America and South America.

We know of no other building system manufacturer having the engineering depth or offering the level of service and technical support to endusers, contractors, architects and consultants. That has become the hallmark of Zamil Steel.

### For the Building Planner

Design your next building project in steel from **ZAMIL STEEL.**

No professional group is more important to the success and growth of the pre-engineered steel buildings industry, and to Zamil Steel, than architects and consultants.

### We Welcome your Technical Inquiries

Zamil Steel welcomes technical inquiries from architects and consultants. We are prepared to assist you in writing specifications for pre-engineered steel buildings and to recommend suitable solutions to your building requirements. Inquiries may be submitted to the attention of the local area manager (at any of Zamil Steel's 34 Area Sales Offices throughout the world) or to the General Sales Manager at Zamil Steel Head Office. Zamil Steel will respond professionally and quickly with viable and practical solutions.

### No Limit to Architectural Imagination

Many impressive architectural projects have used pre-engineered steel buildings. Nowhere has this been more evident than in the USA. Although this



trend is developing in Asia and Africa, still not many architects on these continents have fully realized the economy, versatility and aesthetic features of pre-engineered steel buildings.

### Attend our Product Seminars

Zamil Steel conducts annual product orientation seminars in regions where Zamil Steel maintains offices.





The primary purpose of these seminars is to familiarize architects and designers with the pre-engineered building industry, to highlight to them the vast range of applications for pre-engineered buildings and to encourage them to consider pre-engineered buildings in their forthcoming building projects.

### We Offer Customized Support

If you have just started work on a new building project or if you are working on the initial phase of a building project, we urge you to contact the closest Zamil Steel Area Office to assist you in finding ways that will make you benefit from pre-engineered building system's economy and aesthetics without sacrificing the integrity of your conceptual design. Zamil Steel will provide proposal drawings and building details to you at no cost and without any obligation on your part. This support is intended to extend the awareness of professional designers and specifiers in the use of pre-engineered steel buildings.



A Zamil Steel Proposal Drawing



Pre-engineered buildings (PEBs) use a pre-determined inventory of raw materials that has proven over time to satisfy a wide range of structural and aesthetic design requirements. This flexibility allows PEBs to fulfill an almost unlimited range of building configurations, custom designs, requirements and applications.

A pre-engineered steel building is a building shell utilizing three distinct product categories:



- Built-up “I” shaped primary structural framing members (columns and rafters)
- Cold-formed “Z” and “C” shaped secondary structural members (roof purlin, eave struts and wall girts)
- Roll formed profiled sheeting (roof and wall panels)

Optional structural subsystems are widely incorporated into pre-engineered buildings and provide *functional* as well as *aesthetic* features.



**Functional subsystems** include *mezzanine floors* (including joists and decking), *crane runway beams* (to support crane systems), *roof platforms*, *catwalks*, etc.

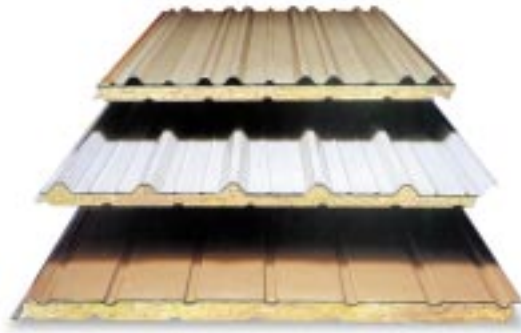

**Aesthetic features** include *fascias*, *parapets*, *canopies* and *roof extensions*.

Until 1990, the use of pre-engineered buildings was confined mostly to North America and the Middle East. Since then, the use of pre-engineered buildings has spread throughout Asia and Africa where the PEB construction concept has now been widely accepted and praised.

A growing number of prominent international contractors and designers, who previously specified conventional structural steel buildings exclusively, have recently converted to the pre-engineered building approach. They now enjoy significant cost savings and benefits from the faster construction cycle resulting from this concept.

From excavation to occupancy no other building system matches the pre-engineered building system when it comes to speed and value.

The advantages of pre-engineered steel buildings are numerous and are the major reason for the spectacular growth of the PEB industry during the past 50 years. These advantages include:



### Low Initial Cost

- The use of tapered built-up primary structural members (columns and rafters) usually results in up to a 40% weight advantage for the main rigid frames when compared to the use of conventional hot rolled sections as primary members.
- The use of “Z” shaped secondary structural members (roof purlins and wall girts), particularly the overlapping of the “Z” shaped purlins at the frames, results in up to a 30% weight saving for the secondary members when compared to the use of hot rolled channels as purlins and girts.
- The manufacturing scrap from the production processes of built-up plate members and cold-formed “Z” sections is typically 75% less than the scrap costs generated from the fabrication of hot rolled members.



- The foundation requirements of pre-engineered steel buildings are fewer and lighter. This is due to wider clear span capability of main frames, longer economic bay lengths and lower weight of the overall PEB steel structure.
- The cost of initial engineering of the structure, as well as later design revisions, is substantially reduced due to the inclusion of the engineering costs within the supply price of the pre-engineered building.



### Superior Quality

- Design quality is consistent and is based on the latest USA codes applicable to the design of pre-engineered steel buildings.
- Welding is performed by AWS certified welders and conforms to the latest version of the Structural Welding Code for Steel published by the American Welding Society.
- Raw materials are ordered to ASTM (American Society of Testing Materials) standards, or equivalent, and are inventoried at the factory adequate with mill certificate traceability.



- Strict adherence to code-specified design live load and wind speed ensures that safety and design integrity are not sacrificed.
- A published standard Quality Plan, with stringent in-house quality control, ensures that manufacturing complies with the acceptance criteria of applicable codes.
- An executive level Quality Assurance Department ensures that quality control checking procedures are adhered to throughout the order processing cycle.

### Fast Project Construction

- Anchor bolt setting plans and anchor bolts can be delivered earlier than the building supply to enable the construction of foundations prior to delivery of the steel buildings.
- Standard building(s) delivery is only 8 weeks (including engineering time) and may be reduced to as low as 6 weeks for special “fast track” projects.
- Fast erection of the steel building(s) because all structural members are field bolted using clear



user-friendly erection drawings. (The typical erection time per erection crew is 1.0 man-hour per square meter).

### Functional Versatility

- Modular construction. (Both the length and the width can be increased incrementally).
- Large unobstructed space utility.
  - Clear spans up to 80 m.



- Bay lengths up to 10 m. (Use of jack beams allows bay lengths up to 20 m).
- Eave heights up to 30 m.
- Buildings are easily expandable on all sides (allowing for future expansion).
- Building shell is designed to accept stocked (custom manufactured) standard accessories (personnel doors, sliding doors, roof ventilators, louvers, windows, skylights, etc.)
- Building design can incorporate additional standard structural subsystems such as



mezzanines, cranes, roof platforms, etc.

#### Architectural Flexibility

- Aesthetic features such as fascias, parapets and curved eaves greatly enhance the architectural appearance of the building and empower designers to create unique buildings.
- Standard and special trims and flashing are available in a wide range of shapes, sizes and colors.

- A wide range of wall panel profiles and colors provides diverse architectural accents.
- Readily available interface details between steel and other façade materials (such as glazing, blockwall, curtainwall, etc.) allow for wider applications.

#### Low Maintenance and Operating Costs

- Virtually no maintenance required for wall panels.
- Roof panels require only periodic cleaning.



- Annual washing of eave gutters.
- Watertight roofs. (Zamil Steel recommends erection by a certified builder).
- Energy efficient roof and wall systems. (When field insulated with standard fiberglass insulation or when clad with insulated Tempcon panels, power usage will be dramatically reduced).



In the USA, where the PEB concept was originally conceived during the early years of this century, nearly 70% of all single storey non-residential construction now utilizes pre-engineered buildings. Applications range from small car parking sheds to 90 m (+), wide clear span aircraft hangars to low-rise multi-storey buildings. Almost every conceivable building use has been achieved using the pre-engineered building approach.



The most common applications of pre-engineered buildings are:

### Industrial

- Factories
- Workshops
- Warehouses
- Cold stores
- Car parking sheds
- Slaughter houses
- Bulk product storage

### Commercial

- Showrooms
- Distribution centers
- Supermarkets
- Fast food restaurants
- Offices
- Labor camps

- Service stations
- Shopping centers

### Institutional

- Schools
- Exhibition halls
- Hospitals
- Theaters/auditoriums
- Sports halls



### Recreational

- Gymnasiums
- Swimming pool enclosures
- Indoor tennis courts

### Aviation & Military

- Aircraft hangars
- Administration buildings
- Residential barracks
- Support facilities

### Agricultural

- Poultry buildings
- Dairy farms
- Greenhouses
- Grain storage
- Animal confinement









**“To appreciate us you must first know us”**

This section is intended to acquaint you with the Zamil Steel organization and to advise you on how to efficiently interact with the different groups within it. Zamil Steel is organized into three divisions. These are:

- The Pre-Engineered Buildings Division (PEB)
- The Structural Steel Division (SSD)
- The Towers and Galvanizing Division (T & G)

Each division has its own factory and is led by a Vice President or a General Manager who reports to Zamil Steel executive management, which is comprised of the President and the Senior Vice President.

The following corporate departments support and service all three divisions and are considered shared resources. Their managers report directly to the Zamil Steel executive management.

- Finance
- Human Resources
- Purchasing
- Facilities Engineering
- Information Technology
- Quality Assurance
- Transport

- Quality Assurance
- Transport

Since this manual is focused on the pre-engineered steel building product line, only the organization of that division will be presented in detail.

### Pre-Engineered Buildings Division

Head Office Organization:

The following departments at the Head Office constitute the core of the Pre-Engineered Buildings Division:

- Marketing
- Products Research & Development (Product Enhancement, Product Development, Engineering Software Development)
- Estimating
- Customer Service
- Engineering (Design and Drafting)
- Manufacturing (Production Control, Production, Industrial Engineering, Shipping and Plant Maintenance)
- Quality Control
- Construction (Erection and Erection Supervision)

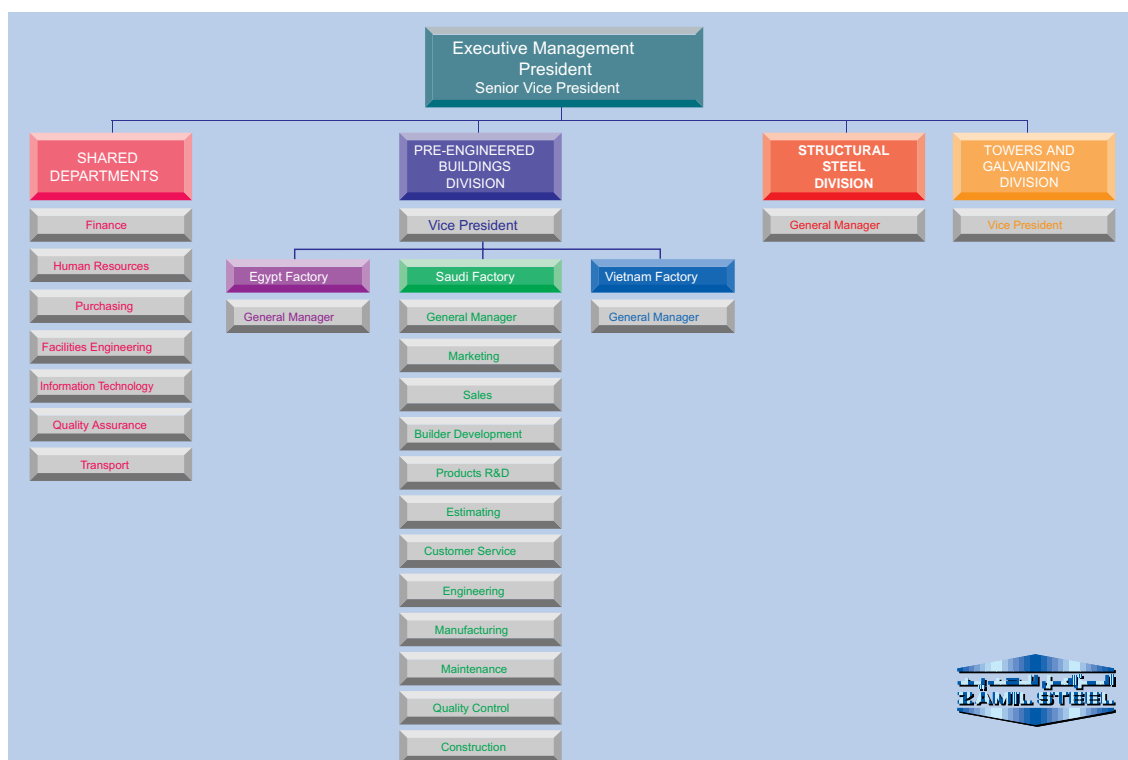





**Products**

The following products are manufactured and marketed by the Pre-Engineered Buildings Division:

- Pre-Engineered Steel Buildings
- Space Frame Structures
- Insulated Sandwich Panels
- Open Web Steel Joists
- Building Components

**Area Sales Offices**

Zamil Steel Sales Department is structured into 5 regions:

- Saudi Region
- Gulf Region
- Intercontinental Region
- Pacific Region
- Africa Region

An updated list of Zamil Steel Area Offices and their respective sales territories is published monthly by the Marketing Manager at the Head Office and may be obtained from any Area Office.

- Saudi Region** Saudi Arabia (Dammam, Riyadh & Jeddah)
- Gulf Region** Kuwait (Kuwait City)  
Bahrain (Manama)

- Qatar (Doha)  
UAE (Dubai & Abu Dhabi)  
Oman (Muscat)  
Yemen (Sanaa)

- Intercontinental Region** Jordan (Amman)  
Lebanon (Beirut)  
India (Chennai)  
Pakistan (Lahore)  
Sri Lanka (Colombo)  
Bangladesh (Dhaka)  
Czech Republic (Prague)  
Romania (Bucharest)  
Greece (Athens)  
France (Paris)  
Poland (Warsaw)

- Africa Region** Egypt (Cairo, Alexandria, Port Said & Assuit)  
Sudan (Khartoum)  
Ethiopia (Addis Ababa)  
Ghana (Accra)  
South Africa (Johannesburg)

- Pacific Region** Thailand (Bangkok)  
Myanmar (Yangon)  
Vietnam (HCMC, Hanoi & Haiphong)  
China (Shanghai)  
Philippines (Manila)  
South Korea (Seoul)



## Certified Builders

Certified builders are independent contractors that are an extension of Zamil Steel in specific sales areas. They have one or more high level managers with extensive experience in pre-engineered steel buildings. Certified builders are appointed for a period of one calendar year, renewable subject to continued demonstration of good performance and high ethical standards. Zamil Steel certification of a builder is conditional upon his continued adherence to Zamil Steel recommended erection practices, adherence to other relevant industry valid construction practices and ethical business practices. Certification is valid for a defined sales territory.

Certified builders specialize in the turnkey construction of pre-engineered steel buildings which normally includes erection services, civil works, foundations, concrete works, finishing, electrical, mechanical, lighting, etc.

Some certified builders offer complementary design and architectural services; some offer a complete design/build service.

Zamil Steel strongly recommends that the erection of its buildings be undertaken only by a Zamil Steel certified builder.

An *updated list of certified builders* is published monthly by the Marketing Manager at the Head Office and may be obtained upon request from any Area Office.

## Your Interaction with Zamil Steel

If you are a consultant, a contractor, or an enduser your interaction with Zamil Steel should be directed through one of the following channels:



- A Zamil Steel Certified Builder
- A Zamil Steel Area Office Staff
- Head Office Marketing Department

We do not encourage direct contact with other departments at the Head Office as it is contrary to internal company policies. You are kindly requested to avoid such contact unless specifically directed to do so by an authorized member of a Zamil Steel Area Office.



Zamil Steel is dedicated to a comprehensive customer support program through a wide range of services, some of which are:

### Area Offices

Area Offices are conveniently located throughout the Middle East, Asia and Africa to enable you to have direct contact with an authorized Zamil Steel company representative. From your first request for a quotation through the actual delivery of materials



at your jobsite to the completion of building(s) erection, you are assured that a dedicated Zamil Steel representative is present to assist you every step of the way. This direct involvement assures you that your order is being professionally handled.

### Consultants and Architects Support

This document, compiled by Zamil Steel, is the most comprehensive technical manual in the Industry. Its table of contents makes it a *quick reference manual*, easy to use and easy to understand.

Since Zamil Steel has an ongoing product review and enhancement program, we reserve the right to change and improve the products as such improvements are identified, tested, and

implemented. This manual is annually revised and reissued to keep it current on our products and services.

No other company offers a wider range of free technical services to consultants and contractors to encourage them to exploit the practical features of pre-engineered steel buildings. Zamil Steel will assist you in developing an appropriate interface detail (between the pre-engineered steel building and another building subsystems) without sacrificing the integrity of your overall design concept. This support is available from the Head Office or through your Area Office contact.

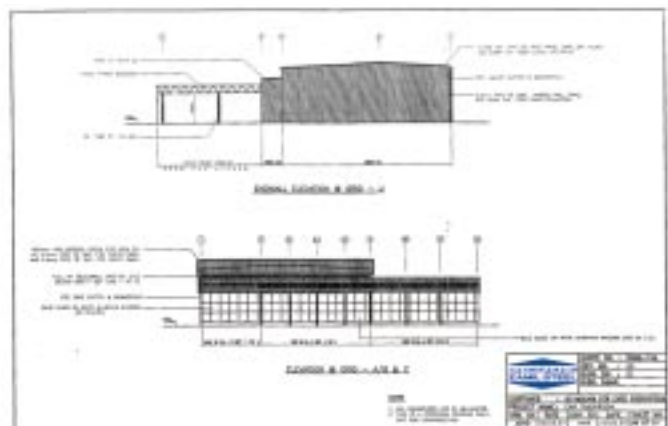

A Zamil Steel Proposal Drawing

### Fast Quotations Turnaround

Every attempt is made to respond to customer requests for quotations in the shortest possible time. The form of the request-for-quotation and the engineering complexity of the building greatly affect our response time. Inquiries containing several special (or complex) buildings may require estimating at the head office and additional design engineering input.

## Comprehensive Quotations and Proposal Drawings

Zamil Steel provides detailed easy to follow quotations, in most cases with proposal drawings, to enable you to verify our understanding of your requirements.

Proposal drawings consist of a column layout plan, a cross-section and four wall elevations for each building. Wall accessories such as doors, windows,



louvers and framed openings are located on these proposal drawings (when locations are known) giving you an opportunity to confirm or change their location prior to the purchase agreement.

Before you buy you see exactly what you are buying.

## Fast Delivery

Zamil Steel operates the largest *single* factory for the manufacture of pre-engineered steel buildings in the world. Our standard ex-works factory delivery starts at 6 weeks for relatively uncomplicated buildings. The delivery period of an order is primarily a function of the engineering complexity of the buildings in the project (which affects both engineering and manufacturing cycle times) and the size of the project.

## Erection Support

A Site Specialist, available at each Area Office, is your assurance that Zamil Steel buildings are erected in strict conformance to the erection drawings. The Site Specialist provides erectors with sound advice and guidance regarding material receiving/unloading procedures, jobsite material storage management, identification of the appropriate erection tools and equipment and efficient building erection sequencing. His involvement begins immediately after a job is released to fabrication and ends when the job is fully erected.



## Long Term Commitment

Zamil Steel is an established and proven manufacturer of steel buildings. When you deal with Zamil Steel you have the comfort of knowing that no matter who your contact is at Zamil Steel, you are dealing with a company that honors its commitments to you today, tomorrow and long into the future.

### Certified Builders

If you are an enduser a Zamil Steel certified builder can offer you a complete turnkey service which saves you the project management costs of coordinating several subcontractors.

If you are the main contractor, the least that a Zamil Steel certified builder can do for you is to undertake the erection of the Zamil Steel pre-engineered steel building in a professional and timely manner. Knowledgeable and updated on the most recent products, policies and procedures, the certified builder is your representative within the Zamil Steel organization.



### Future (Building) Modifications

Designs and drawings for your building are stored at Zamil Steel Head Office archives indefinitely. This enables you to refer to Zamil Steel at any time in the future to confirm the original design criteria before you plan major modifications to your building. Zamil Steel can perform design calculation checks and will update your original erection drawings to bring them to 'as-built' condition.

### Future Parts Replacements

Should any accessory or part of a Zamil Steel building be damaged or need replacement in the future, all you have to do is call a Zamil Steel certified builder or a Zamil Steel Area Office. The component can be supplied by Zamil Steel within a short time and promptly installed by a Zamil Steel certified builder.



Zamil Steel is committed to producing marketing literature that contributes to the education of all parties involved in the purchase of a Zamil Steel pre-engineered steel building. Every effort is made to update this literature on an annual basis.

Effective July 1999, most of Zamil Steel marketing and technical literature will be available in digital format on CD-ROM.



- Erection Manual
- Owners Maintenance Manual
- Pre-Engineered Steel Buildings Versus Conventional Steel Buildings Brochure
- Foundation Design Guide for Zamil Steel Pre-Engineered Steel Buildings
- Zamil Steel Corporate Video & CD-ROM
- Pre-Engineered Buildings Technical Video
- Buildings Around The World CD-ROM

### Space Frames Structures

- Product Brochure
- Technical Manual

The following Zamil Steel literature is currently available and may be obtained from the Marketing Manager at Zamil Steel Head Office or from any Zamil Steel Area Office.

### Pre-Engineered Steel Buildings

- Product Brochure
- Technical Manual
- Insulated Sandwich Panels Brochure
- Pre-Qualification Documents
- Panel Chart (colors & profile)
- Standard Product Specifications
- Standard Terms and Conditions of Sale
- Components Manual

# CHAPTER 1 : INTRODUCTION

## Section 1.8 : Zamil Steel Literature

2 of 2

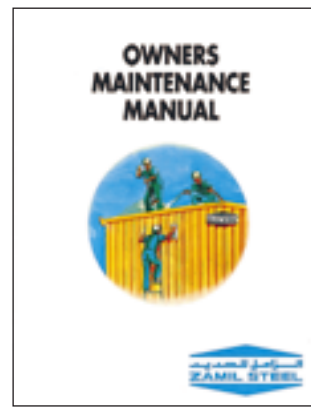
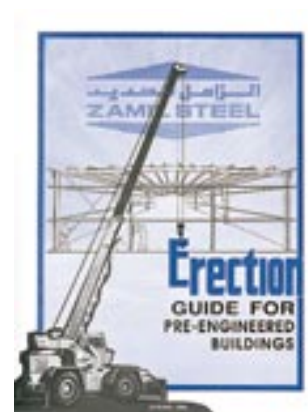
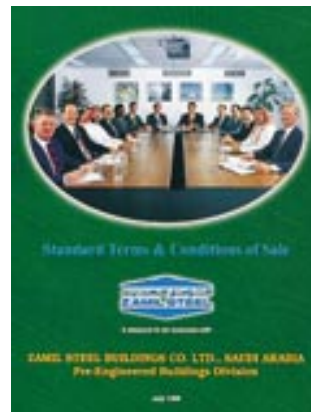
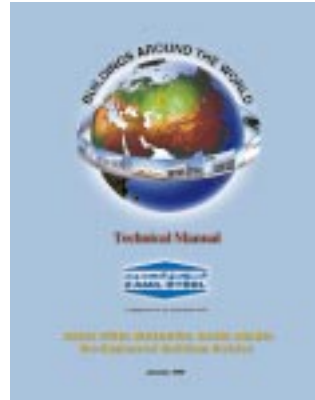

Requests for quotation should be submitted through a Zamil Steel Area Office or through a Zamil Steel certified builder. When you are unsure as to which Zamil Steel Area Office to contact, please contact the Marketing Manager at Zamil Steel Head Office who will direct you to the responsible Area Office.

There are two distinctly different ways to request a quotation for a Pre-Engineered Steel Building :

**Method I: Provide Basic Building(s) Data**

When it is possible to define and provide us with the basic building dimensions (width, length, eave height) and design loads (live load, wind speed, collateral loads, etc.) and Zamil Steel’s standard design approach, manufacturing criteria and materials are acceptable to you, a comprehensive quotation offer based on Zamil Steel standards can be submitted to you within 3 - 7 days by the Area Office.

The interactive nature of this method coupled with the experienced input of a professional Zamil Steel representative often results in shorter deliveries and up to 20% cost saving for the pre-engineered steel buildings.

Approximately 80% of Zamil Steel jobs (orders) are processed from this form of input.

**Method II: Provide Consultant Drawings and Specifications**

Submission of consultant drawings and design specifications as the input for a request for quotation often requires a comprehensive review and thorough analysis of drawings and specifications at Zamil Steel Head Office. This ensures that deviations from specifications and exclusions of special items (outside the scope of Zamil Steel’s normal supply) are appropriately highlighted in our comprehensive quotation offer.

A complete quotation offer for such projects may take up to 10-20 days to prepare depending on the engineering complexity of the buildings.

*A picture is worth a thousand words: Always request proposal drawings from Zamil Steel.*

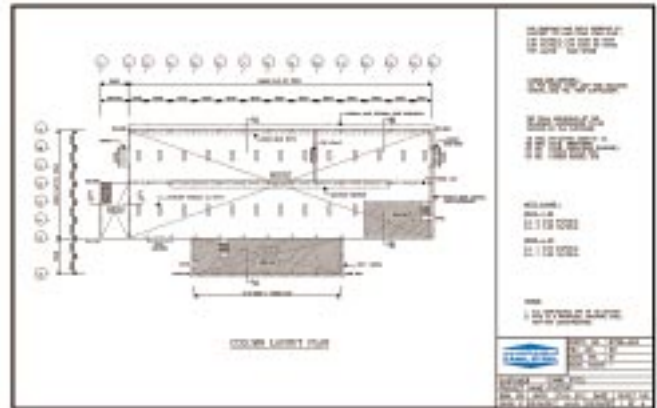

*A Zamil Steel Proposal Drawing*

Most mistakes occur due to miscommunication between a buyer and a seller and/or because of a misinterpretation, by either party, of the information provided. Zamil Steel proposal drawings enable you to verify our interpretation of your requirements and ensure that the final supply is in complete conformance to your needs.





The purpose of including this section is to inform you of the internal procedures followed by Zamil Steel from the time a contract is signed to the time we ship your building. We wish to make you aware of the various factors that may affect Zamil Steel's processing of a job and the impact that changes or clarifications may have on our delivery commitment. In some cases, delivery delays are avoided by more knowledge of the internal Zamil Steel work flow procedures.

This section should be read in conjunction with Zamil Steel's "Standard Terms & Conditions of Sale", a copy of which can be obtained from the Marketing Department at Zamil Steel Head Office or from any Zamil Steel Area Office.

As in the case of quotations, actual orders should be processed through a Zamil Steel Area Office or through a Zamil Steel certified builder. This section specifically addresses orders that are placed through a Zamil Steel Area Office. Orders that are placed through a Zamil Steel certified builder generally follow a similar process.

### Placing an Order

Orders are placed after Zamil Steel submits a typed and signed quotation offer (proposal) to you and it is signed by you. The quotation offer (proposal) is often revised one or more times until all technical and commercial matters are agreed upon. In most projects, Zamil Steel includes proposal drawings to enable you to review and verify Zamil Steel's interpretation of your exact building requirements.

For an order to be valid and binding, your authorized representative and the Zamil Steel Area Office representative must fill and sign a standard contract form which is attached to all Zamil Steel typed quotation offers.

*Important:* Should any word or statement on any

page of the quotation offer or contract be changed prior to signing the contract, the word or statement should be crossed out and the acceptable wording re-written clearly (in block letters) immediately adjacent to the change. Both your representative and the Zamil Steel representative must initial the hand-written change.

A copy of all contract documents is then immediately given to you for your file.

### Order Processing by Zamil Steel Area Offices

The Zamil Steel Area Office representative transfers all relevant order information from the typed quotation offer onto internal Zamil Steel forms, and dispatches the original forms with the original contract documents to Zamil Steel Head Office. A copy of the forms and the contract documents are retained at the Area Office.

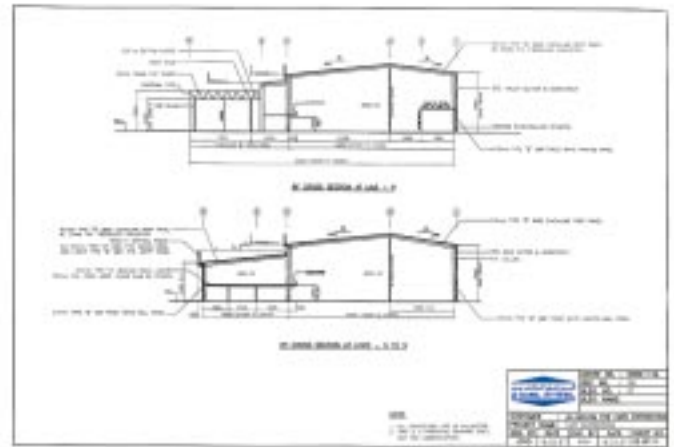

*A Zamil Steel Proposal Drawing*

### 1. Receipt at Head Office

An order is first received at Zamil Steel Customer Service Department. This department is responsible for reviewing the order to ensure that all technical, logistical and financial matters are complete and are in accordance with Zamil Steel policy.

## 2. Design

The screened order is then passed to the Engineering Department for final technical evaluation and for actual engineering of the building(s) in the job. Engineering may, during the process of thorough analysis and design, uncover discrepancies, missing information or contradictory information that may require further clarification.

If this occurs, a questionnaire is prepared by the Engineering Department, verified by the Customer Service Department and submitted to you through your local Zamil Steel Area Office. Prompt response from you for such technical clarification will minimize delays in engineering and consequent delays in fabrication and delivery.

## 3. Preparation of the Approval Package (if applicable)

An approval package normally consists of design calculations and approval drawings. Work on the approval package commences when the Engineering Department has no queries regarding the data provided by you and/or is satisfied that your response to technical queries is complete.

## 4. Dispatch of the Approval Package (if applicable)

The completed approval package is passed from the Engineering Department to the Customer Service Department which then dispatches the package to your local Zamil Steel Area Office for submission to you. Zamil Steel Customer Service Department does not normally dispatch approval documents directly to the buyer. The Area Office is expected to personally submit the approval package to the buyer and to be available to the buyer for consultation at this stage of the order process.

## 5. Awaiting return of Approval Drawings (if applicable)

Once the Head office approval drawings are with you, Zamil Steel effectively suspends further action on the job, awaiting the return of the approval drawings with your full approval or your conditional approval based on clearly noted remarks on the approval drawings.



## 6. Return of Approval Drawings to Zamil Steel (if applicable)

Approval drawings are required to be returned to the relevant Zamil Steel Area Office within two weeks of their submittal to you. Approval drawings must be signed by you as “**Approved As Is**” or signed as “**Approved As Noted**”. Returned approval drawings are forwarded by the Area Office back to the Customer Service Department where they are reviewed and passed to the Engineering Department for final production engineering. The production engineering output consists of the preparation of anchor bolts plans, erection drawings, shop details and bill of materials.



**Major** changes to the approval drawings may result in one or more of the following:

- Re-design of structural elements in the building(s)
- Re-estimate of the price of the building(s)
- Re-submittal of approval drawings for the building(s)
- Creation of a change order that may affect the price and/or the delivery of the building(s)

## 7. Change Orders

Changes made after a contract is signed (whether occurring at the approval stage, the production engineering stage or the fabrication stage) that result in an increased price or extended delivery, necessitate the creation of a change order. Until the change order is signed as accepted by you, and returned to the Zamil Steel Area Office, no further work is undertaken on the job.

## 8. Production Engineering Output

Returned approval drawings are received at the Head Office by the Customer Service Department. They are reviewed for changes and/or customer comments. If no changes are noted or if only minor changes are noted, they are passed to the Engineering Department for preparation of the production engineering output which consists of the following:

- Anchor bolts plans (for construction)
- Erection drawings (for construction)
- Shop details (for production)
- Bill of materials (for production and shipment)

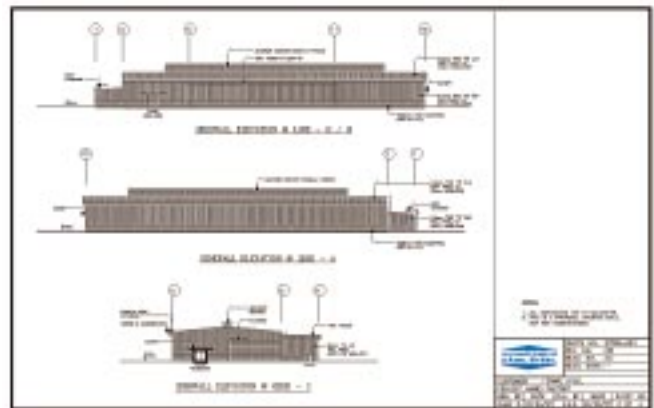

*A Zamil Steel Proposal Drawing*

## 9. Schedule for Manufacturing

Upon the **timely** return of approval drawings (i.e., if no major changes were noted that require processing a change order or a re-submittal of approval drawings) and upon the fulfillment of payment terms (i.e., Finance Department has released the job for production) the job is immediately **scheduled for production**. The job is scheduled in accordance with the delivery commitment specified in our signed contract or our last change order letter.



## 10. Start of Manufacturing

Manufacturing of a building starts after the Engineering Department releases the **Shop Details** and **Bill of Materials** of all the components for the building to the Production Control Group which is a part of the Manufacturing Department.

## 11. Completion of Manufacturing

For small and medium size jobs, manufacturing and painting is normally completed 3 weeks after the start of manufacturing. Complex jobs often take a longer time. Very large jobs may be manufactured

progressively over a longer period of time allowing for phased partial shipments, normally commencing within 4 weeks from the start of manufacturing.

## 12. Shipment of Material

For small and medium orders and for partial shipments of large orders, packing, document legalization, truck loading and dispatch are normally effected within 2 - 5 days from completion of manufacturing.



All materials shipped by Zamil Steel are carefully and safely loaded (onto trailers for overland shipment, or into closed containers for sea freight) with detailed packing lists clearly cross referencing the bill of materials and erection drawings. It should arrive at your site complete and in prime condition.

# NOMENCLATURE

# C H A P T E R 2

## 2. Nomenclature

21	Basic Terms.....	31
22	Abbreviations.....	50

**Accessory:** A supplementary building product, such as a door, window, skylight, ventilator, louver, etc.

**Anchor Bolts:** Bolts used to anchor structural members to a concrete floor, foundation or other support. Usually refers to the bolts at the bottom of all columns and door jambs.

**Anchor Bolt Plan:** A plan view of a building(s) foundations showing all dimensions and sections required to properly locate the anchor bolts, including the projections of the bolts above the concrete surface, required recess, etc. Column reactions (magnitude and direction), and base plate dimensions are also included.

**Angle:** A hot rolled member with two legs forming a 90° angle.

**Approval Drawings:** Drawings sent to the customer to verify design and dimensions and to verify the sales contract description of materials and services the manufacturer has agreed to furnish.

**Assembly:** Two or more components bolted together.

**Astragal:** A bent plate attached to one leaf of double sliding or hinged doors to prevent dust and light ingress.

**Auxiliary Loads:** All specified dynamic live loads, other than the basic design loads, which the building must safely withstand. Examples are loads imposed by crane systems, material handling systems and impact loads.

**Back-up Plates:** Additional plates used in connections to provide sufficient bolt grip, allow for erection tolerances, or increase strength.

**Base Angle:** A continuous angle fixed to the floor slab or to the grade beam to enable the attachment of wall panels.

**Base Plate:** The endplate of a column which rests on the supporting substructure surface.

**Bay:** The space between the center lines of frames or primary supporting members in the longitudinal direction of the building. Also called **Bay Spacing** or **Bay Length**.

**Bead Mastic:** A sealant furnished in a continuous roll, normally used for sealing end laps of roof panels. See also **Endlap Mastic**.

**Beam:** A horizontal structural member designed primarily to resist moments.

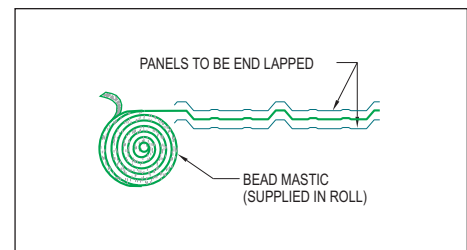
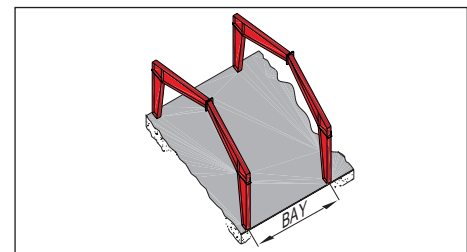
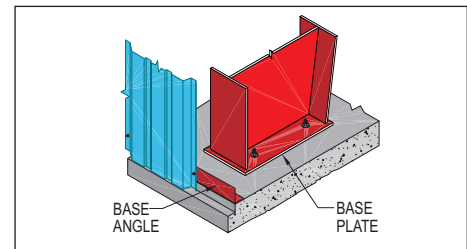
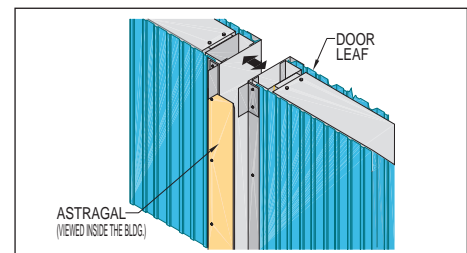
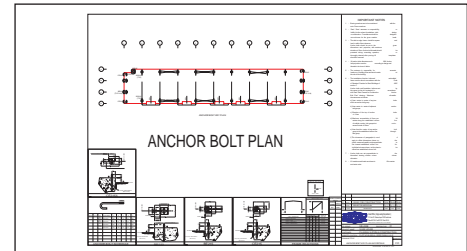
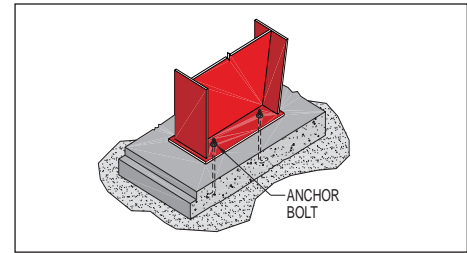

**Bent Plate:** A plate bent to form an angle.

**Bill of Materials:** A list of items or components used for fabrication, shipping, receiving, and accounting purposes.

**Bird Screen:** Wire mesh used to prevent birds from entering the building through ventilators, louvers and roof monitors.

**Blind Rivet:** A small headed pin with an expandable shank for joining light gauge metal. Typically used to attach flashing, gutters, etc. Also referred to as a **Pop Rivet**.

**Brace Grip:** Galvanized steel strands formed into a helical hair pin shape that is wrapped tightly on the strand at the end of the cable brace.

**Brace Rods/Cables:** Rods or cables placed diagonally in the roof and walls for the purpose of transferring wind loads to the foundations and longitudinally stabilizing the building.

**Braced Bay:** The bay where bracing is provided.

**Bracket:** A structural support projecting from a column or rafter to which another structural member is fastened. Example: Brackets supporting crane runway beams.

**Bridge Crane:** Overhead traveling crane supported by rails which are in turn supported by crane runway beams.

**Builder:** A general contractor or sub-contractor responsible for providing and erecting pre-engineered buildings.

**Building Codes:** Regulations developed by recognized agencies establishing minimum building requirements for licensing, safety and functionality purposes such as setbacks, fire regulations, spacing and clearances. Building codes usually address acceptable design codes. An example of a building code is the Uniform Building Code (UBC).

**Building Width:** The lateral width of the building measured from out to out of sidewall steel lines.

**Built-up Section:** A structural member, usually an "I" shape, made from individual flat plates welded together.

**Butt Plate:** The end plate of a structural member which usually rests against a similar end plate of another member to form a moment resisting connection. Also called **Splice Plate**, **End Plate**, or **Cap Plate**.

**By-pass Girt:** The girt which passes continuously along the outside flanges of the columns.

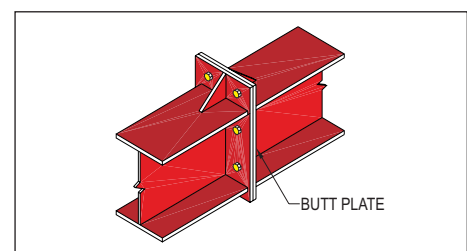
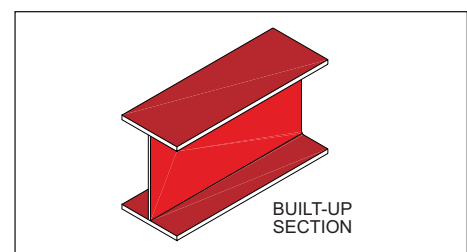
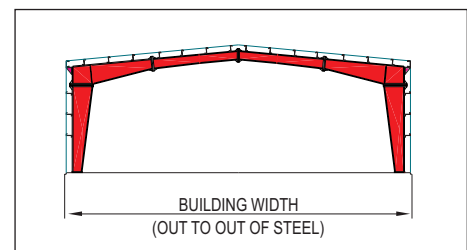
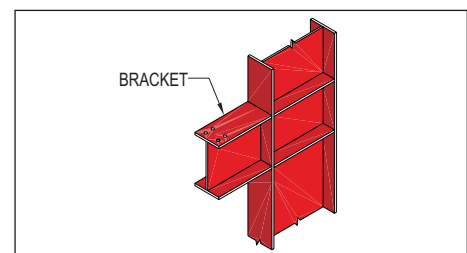
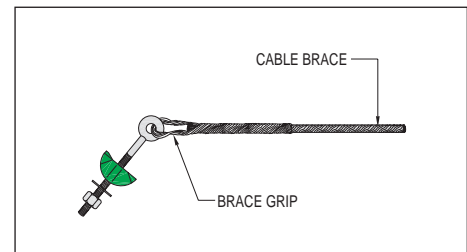
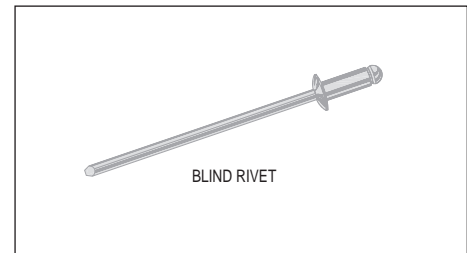



**By-pass Mounted:** See **Exterior Mounted**.

**“C” Section:** A member formed into a “C” shaped profile by cold roll-forming from coils.

**Cable Catch Assembly:** The operating handle used to open and close the ridge ventilator.

**Cables:** Used for cable bracing. Can also be used to operate ridge vent dampers and for temporary bracing. See **Brace Cables**.

**Cantilever:** A projecting beam that is supported and restrained at one end only.

**Canopy:** An overhanging or projecting roof structure, below the eave level, supported at one end only.

**Cap Plate:** A plate located at the top of a column or end of a beam. Also referred to as **End Plate**.

**Capillary Action:** The action of water rising to a higher level.

**Catwalk:** A narrow walkway used to provide access to mechanical equipment normally supported on roof platforms.

**Caulking:** A sealant used in making watertight joints.

**Channel (Hot Rolled):** A member formed, while in a semi-molten state at the steel mill, into a “C” shaped profile having standard dimensions and properties specified by a relevant standard specification.

**Checkered Plate:** Flat hot rolled plate with raised checkered design to prevent slipping; used for industrial equipment platforms, catwalks, stair treads, etc.

**Clear Height:** The vertical dimension from the finished floor level to the lowest underside point of the rafter.

**Clear Span:** A building without internal columns.

**Clip:** A plate or angle used to fasten two or more members together.

**Closer:** Mechanical device, usually attached to a hinged door, which automatically closes the door.

**Closure Strip:** Purpose-made foam fillers to fit inside and outside profiles of roof and wall panels providing a weather-tight seal. Also known as **Foam Closure**.

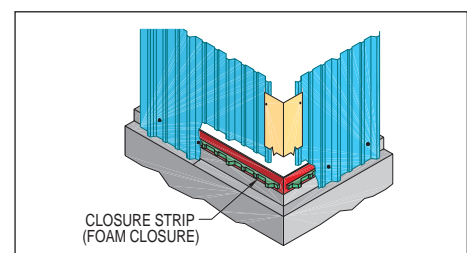
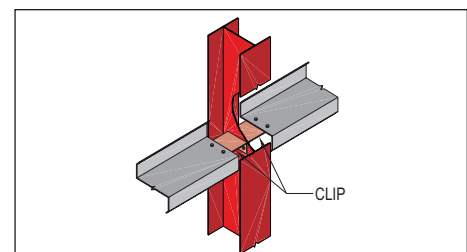
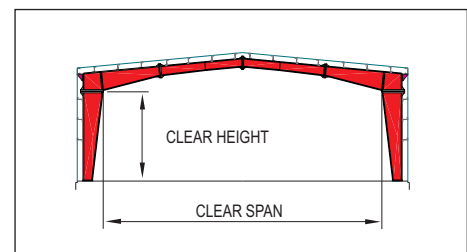
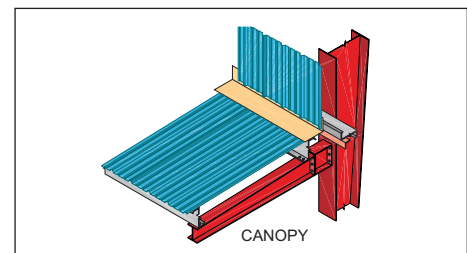
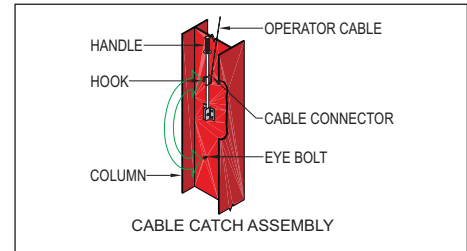
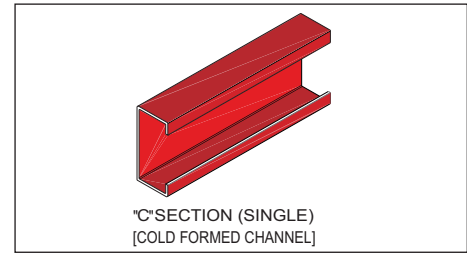

**Coil:** A roll of steel sheet or wire.

**Cold-Formed Member:** A light gauge structural member produced from coiled steel stock running through a series of rolls at normal room temperatures.

**Collateral Load:** The static load other than the basic design loads such as sprinklers, mechanical and electrical systems, ceilings, etc.

**Column:** A vertical structural member used in a building to transfer loads from the main roof beams, trusses or rafters to the foundation.

**Component:** An independent part of an assembly.

**Concrete Notch:** A rebate or notch formed along the edge of the concrete floor slab or grade beam, allowing wall panels to end below the floor level thus preventing ingress of dust or water.

**Continuous Beam:** A beam which has more than two points of support.

**Continuous Ridge Vent:** Two or more ridge ventilators mounted on the building ridge that allow air circulation. See also **Ridge Ventilator**.

**Corner Column:** A column at any corner of a building. Corner columns may be primary rigid frame columns or post-and-beam columns.

**Counter Flashing:** Trim used to connect the sidewall sheeting of a main building to the roof sheeting of a lower building.

**Crane:** A machine designed to lift and/or move material by means of a hoist.

**Crane Beam:** A beam that supports an overhead traveling bridge crane. On underhung bridge cranes, it also acts as a crane rail. Also known as a **Crane Runway Beam**.

**Crane Bracket:** Structural support welded to the primary building frame to permit attachment of a crane runway beam. See also **Bracket**.

**Crane Bridge:** One or two girders or box sections supported on end carriages. See also **Bridge Crane**.

**Crane Capacity:** The maximum weight a crane can safely lift. Crane capacity depends on the standard design of the crane components and their supports.

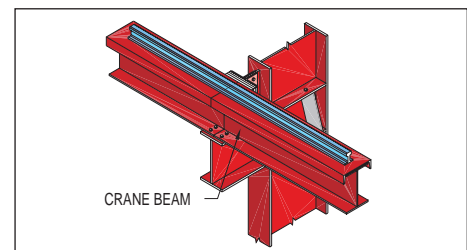
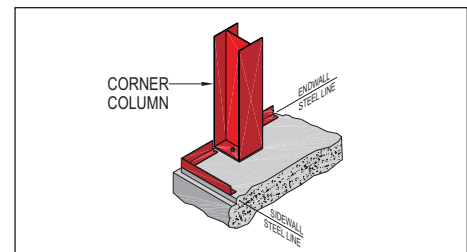
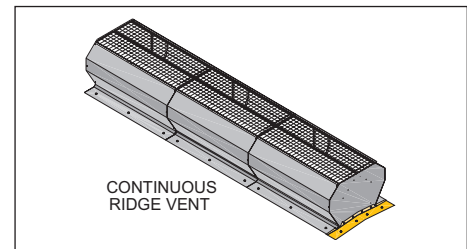
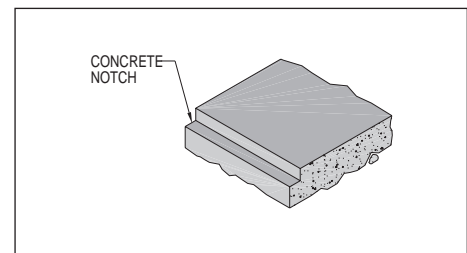
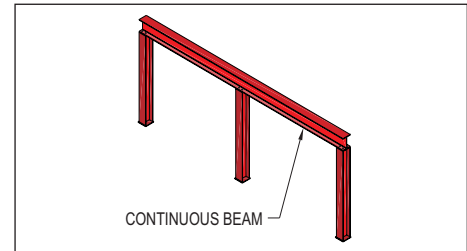
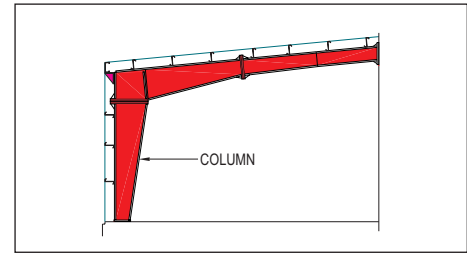

**Crane Rail:** Rail welded or bolted to a crane beam forming the track on which the bridge crane wheels travel.

**Crane Stopper:** A small vertical member welded to the top of the crane beam to stop the crane bridge at the end of the crane run area.

**Cross Section:** A view formed by a plane cutting through an object usually at right angles to its axes.

**Curb:** Raised flashing around roof openings to form waterproof openings. See also **Roof Curb**.

**Curved Eave:** Curved panels provided at the eave.

**Damper:** Baffle plate in a ridge ventilator that can be opened or closed using the cable catch assembly.

**Dead Load:** The self weight of the pre-engineered building structure including all its components such as frames, floors, secondary members, sheeting, bolts, etc.

**Design Codes:** Regulations developed by recognized agencies establishing design loads, procedures, and construction details for structures. Examples are: MBMA, AISC, AISI, AWS, etc.

**Diagonal Bracing:** See **Brace Rods/Cables**.

**Door Guide:** An angle, channel, or proprietary product used to restrain a door leaf or curtain during its opening and closing.

**Door Stopper:** A clip bolted to the vertical door member to prevent opening beyond the door limit.

**Double Channel:** Double or back-to-back “C” sections stitch-bolted together.

**Double Faced Tape:** Used as an aid to fix fiberglass insulation.

**Double Sliding Door:** Sliding door with two door leaves.

**Downspout:** Cold-formed sheet metal section used to carry water from the gutter of a building to the ground or storm drainage system.

**Downspout Elbow/Shoe:** Cold-formed sheet metal section, matching the downspout profile, attached to the lower end of a downspout and curved in such a way as to direct water away from a wall.

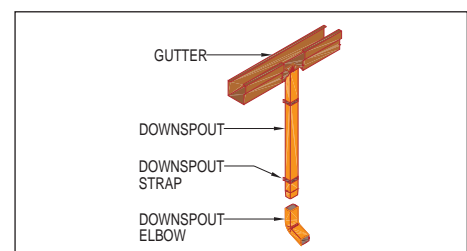
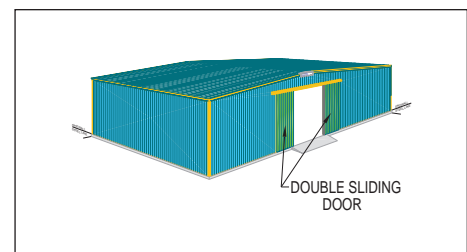
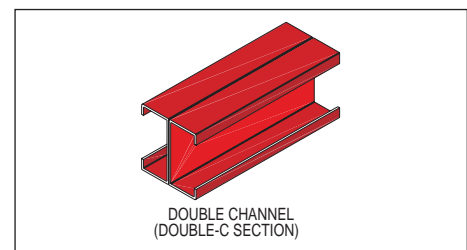
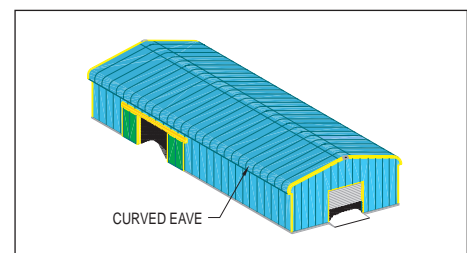
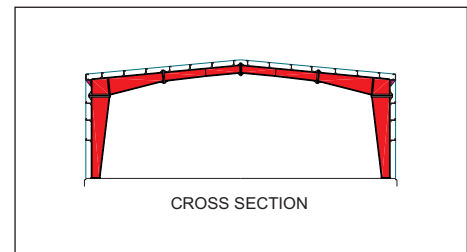
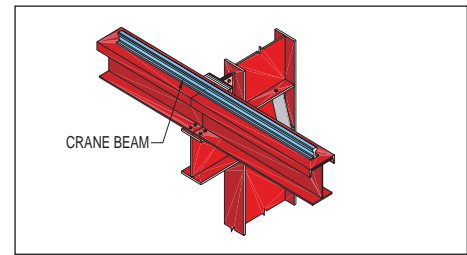

**Downspout Straps:** Metal straps used to fix the downspouts to the sidewalls.

**Eave:** A line along the sidewall formed by the intersection of the inside faces or planes of the roof and the sidewall panels.

**Eave Gutter:** Gutter at the eave of a building.

**Eave Height:** The vertical dimension from the finished floor level to the top of the eave strut.

**Eave Strut:** A structural member, located at the eave, used for supporting the roof panels and the wall panels.

**Eave Strut Clip:** A clip used to support the eave strut.

**Eave Trim/Flashing:** A sheet metal closure whose function is primarily to provide weather-tightness at the eave between the eave gutter and the wall panels.

**Edge Distance:** The perpendicular distance between the plate edge and the center of the bolt hole.

**Elevation:** (a) Distance above or below a prescribed datum or reference. (b) Engineering term referring to any wall view of a structure.

**End Bay:** The first or last bay in the building, as opposed to interior bay. It is the spacing between the outside face of the endwall columns and the center line of the first interior column.

**End Lap:** A term used to describe the lap at a purlin location where the end of one panel overlaps the end of the panel below it.

**End Lap Mastic:** Sealant, in extruded bead form, used to seal end laps of roof panels for weather-tightness. Also called **Bead Mastic**.

**End Plate:** A plate welded at the end of a member.

**Endwall:** A term used to describe the entire composition of a building end. See **Post & Beam Endwall** or **Rigid Frame Endwall**.

**End Wall Framing:** Framing located at the endwall of a building which supports the loads acting on a portion of the end bay.

**Endwall Post/Column:** A vertical member located at the endwall which supports the girts and endwall rafter.

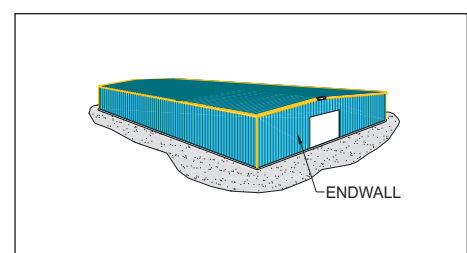
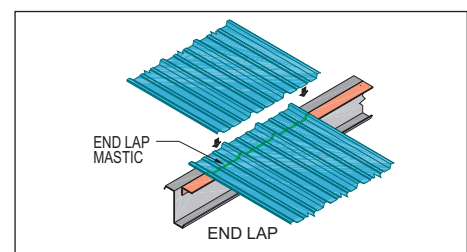
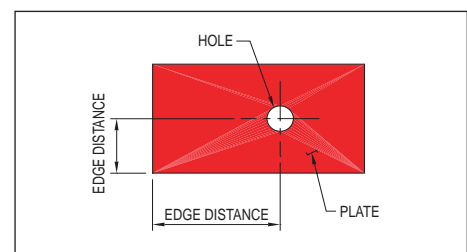
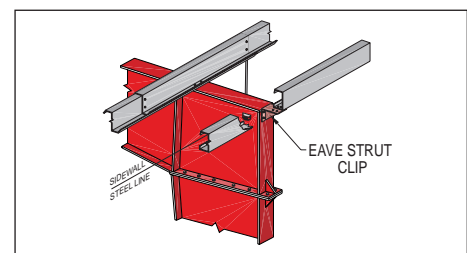
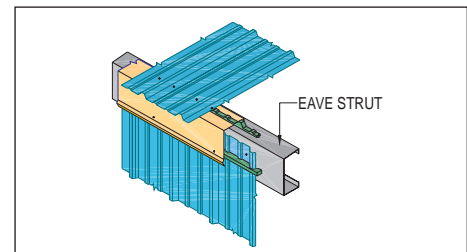
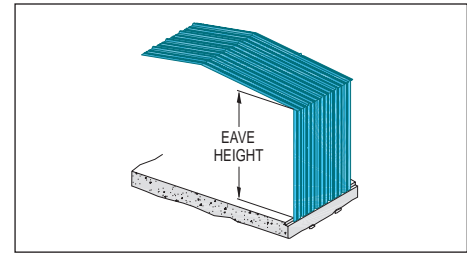

**Endwall Rafter:** Normally a cold-formed “C” section supported by end posts of post-and-beam endwalls. Endwall rafters can also be built-up or hot rolled sections if required by design loads

**Endwall Roof Extension:** Roof cantilevered beyond the endwall.

**Erection:** The on site assembling of pre-fabricated components to form the complete structure.

**Erection Drawings:** Drawings and erection instructions which identify all the individual components in sufficient detail to permit the proper assembly of all parts of the metal building system furnished by the seller.

**Expansion Joint:** A weather-tight joint across the width of the building allowing for expansion and contraction.

**Exterior Mounted:** A girt system where the girts are mounted outside the columns and are attached directly to the outside column flange. Also called **By-pass Mounted**.

**Eye Bolt:** Used in conjunction with a hillside washer for tensioning cable braces.

**Fabrication:** The manufacturing process usually performed in a plant to convert raw material into finished metal building components. The main operations are cold-forming, cutting, punching, welding, cleaning and painting.

**Fascia:** An accessory whose function is to enhance the appearance of a wall. Also used to cover the eave or gable of a building.

**Field Work:** Modification or rectification carried out on site.

**Fin Neck Bolt:** Flat dome headed bolt used in framed openings, fascias, and mezanines.

**Finished Floor:** Top of the concrete slab or the finished concrete surface.

**Fixed Base:** A column base that is designed to resist rotation as well as horizontal or vertical movement.

**Flange:** The projecting edge of a structural member.

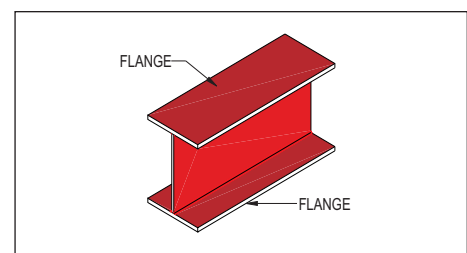
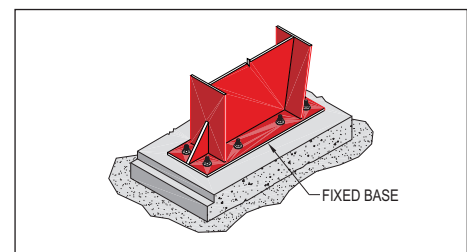
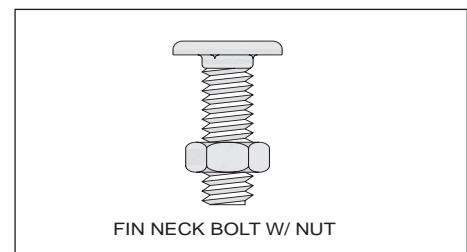
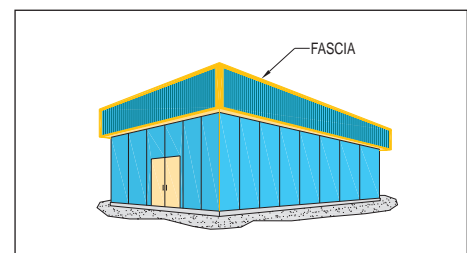
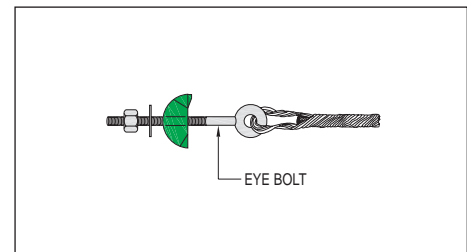
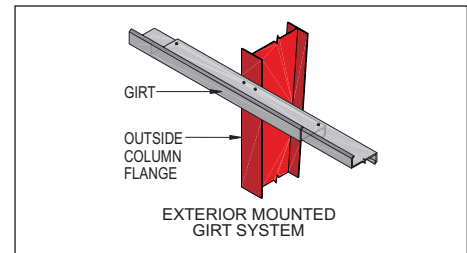

**Flange Brace:** An angle member extending between girts or purlins to the inner flange of columns or rafters respectively, to provide them with lateral support and stability.

**Flashing:** A sheet metal closure used to provide weather-tightness in a structure.

**Flowable Mastic:** Supplied in a nozzled cartridge. Used to seal overlapping flashing, gutter joints, etc.

**Flush Mounted:** A girt system where the outside flanges of the girts and columns are flush. The girts are supported by the use of girt clips bolted to the column webs.

**Footing:** Reinforced concrete base that provides support for a column.

**Force:** The action of one body on another body which changes or tends to change its state of rest or motion. A force may be expressed in kilonewton(s) (kN), or other similar units.

**Foundation:** The substructure which supports a building or other structure. Usually constructed in concrete.

**Framed Opening:** Framing (headers, sills, and jambs) and flashing which surround an opening in a building. Usually provided to accommodate field installed accessories such as sliding doors, roll-up doors, etc.

**Framing:** Primary and secondary members (columns, rafters, girts, purlins, brace cables, etc.) which when connected together make up the skeleton of a structure to which the covering can be fastened.

**Gable:** The triangular portion of the endwall of a building directly under the sloping roof and above the eave height line.

**Gable Angle:** An angle fastened to the purlins at rake for the attachment of endwall sheets.

**Gable Trim:** A flashing designed to close the opening between the roof panels and endwall panels.

**Gage or Gauge:** The distance between holes along the transverse axis of a plate.

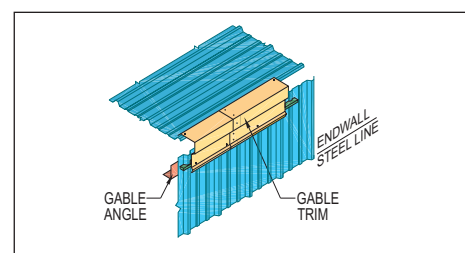
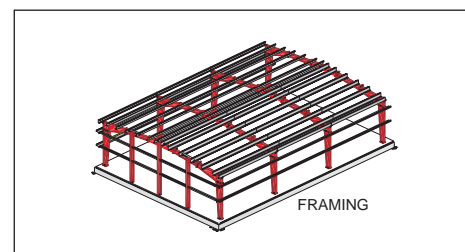
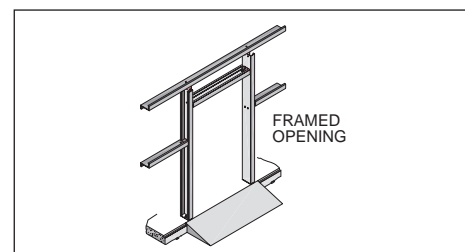
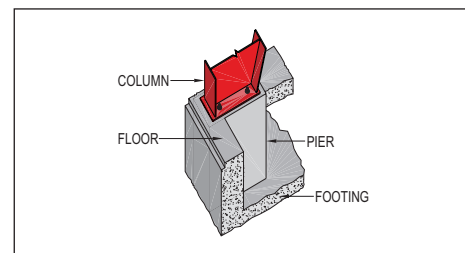
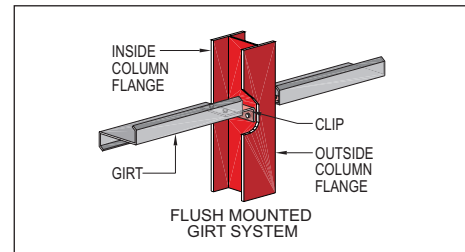
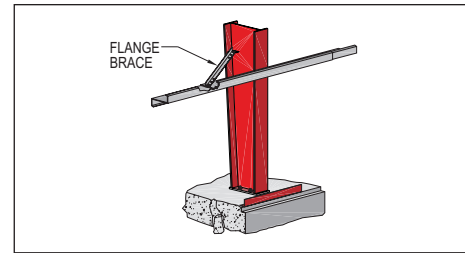

**Galvanized:** Steel coated with a layer of zinc for corrosion resistance.

**Girder:** See **Beam**.

**Girt:** Secondary horizontal member attached to the main frame columns. Girts normally support wall panels.

**Girt Clip:** Angle clips used to connect girts to the endwall columns.

**Glazing:** Installation of glass.

**Grade:** Ground level (or elevation) surrounding a building.

**Grating:** Welded framework of crossbars used in flooring of equipment platforms, platform walkways, catwalks and stair treads.

**Grout:** Non-shrinking sand and cement based mixture used under base plates to obtain a uniform bearing surface.

**Gusset Plate:** Steel stiffener plate used to help distribute load at a connection.

**Gutter:** Pre-formed light gauge metal channel at the roof, along the side walls, or in valleys of multi-gabled roofs for the collection of rainwater.

**“H” Section:** A steel member with an “H” cross section.

**Hair Pin:** Reinforcement bars used in distributing forces from the column foundation to the floor slab.

**Handrails:** Horizontal and vertical pipes fixed to stair stringers, edges of mezzanine floors, openings in floors and platform walkways.

**Hangar Door:** A large multi-leaf door that is used in aircraft hangars or similar buildings.

**Haunch:** Intersection of the column and rafter. Also referred to as **Knee**.

**Header:** A horizontal member over an opening in a wall.

**High Strength Bolt:** Any bolt made from steel having a tensile strength in excess of 690 megapascal (MPa). Some examples are: ASTM A325, A354, A449 and A490.

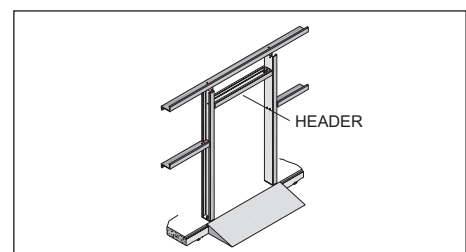
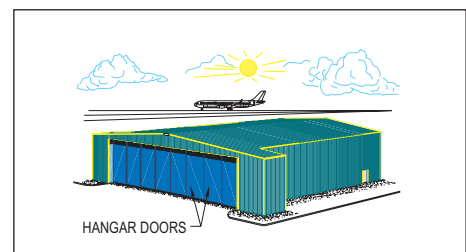
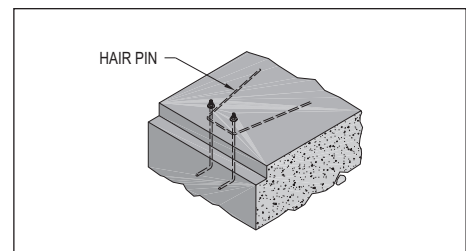
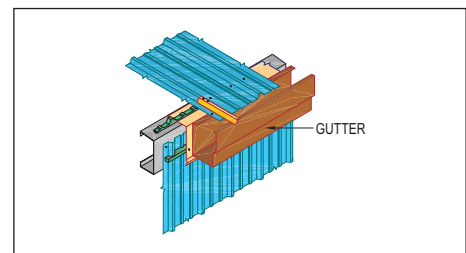
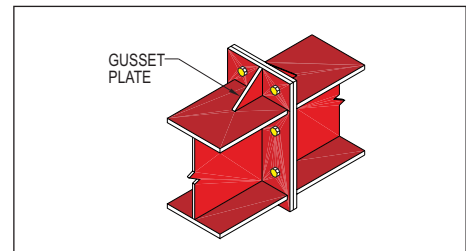
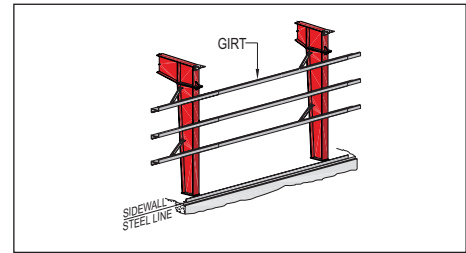

**Hillside Washer:** A washer having non-parallel faces normally used on brace cables or rods. Also known as **Bevel Washer**.

**Hinged Base:** See **Pinned Base**.

**Hoist:** A lifting device that is mechanically, electrically or manually operated.

**Horizontal Knee Splice:** Horizontal connection of the column to the rafter.

**Hot Rolled Shapes:** Steel sections (angles, channels, I-sections, etc.) which are formed, while in a semi-molten state at the steel mill, into a shape having standard dimensions and properties specified by relevant standard specifications.

**Impact Load:** A dynamic load resulting from the motion of machinery, cranes, elevators and other similar moving forces.

**Insulation:** Any material used in building construction for the reduction of heat transfer.

**Interior Bay:** The distance between the center lines of two adjacent interior rigid frames.

**Intermediate Rafter Splice:** Connection of two pieces of the rafter.

**Jack Beam:** A primary horizontal member used to support another beam, truss or rafter.

**Jamb:** Vertical member at the side of a wall opening.

**Jib Crane:** A cantilever boom or horizontal beam with a hoist and trolley.

**Joist:** A horizontal member for supporting the decking of floors or roofs.

**Knee:** See **Haunch**.

**Lean-To:** A structure dependent upon another structure for partial support and having only one slope or pitch.

**Liner Panel:** Interior wall or roof sheeting attached to the inside flanges of the girts or purlins.

**Lintel:** A beam (either concrete or steel) in masonry walls placed above doors, windows or openings to support masonry above.

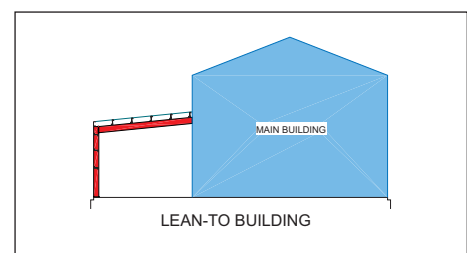
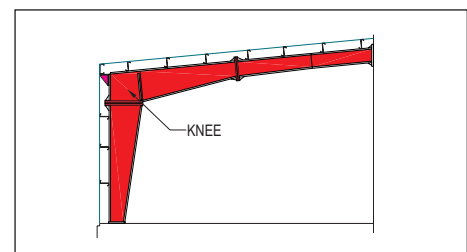
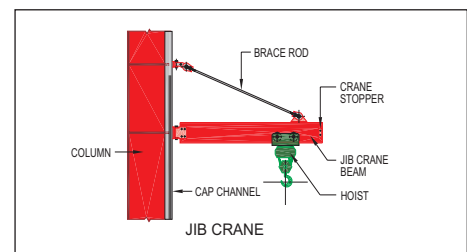
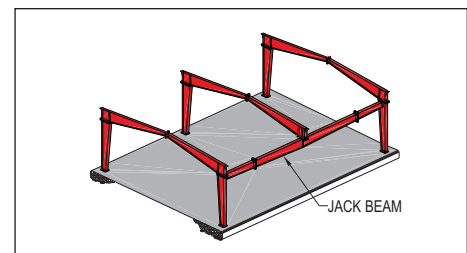
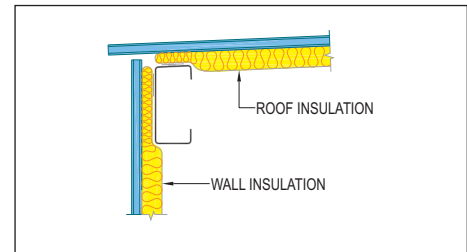
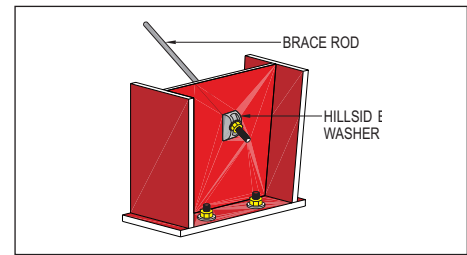



**Live load:** Any variable load that results from intended use of the structure during its life time.

**Loads:** Anything that causes a force to be exerted on a structural member. Examples of different types of loads are:

- a) Dead Load
- b) Live Load
- c) Impact Load
- d) Seismic Load
- e) Wind Load
- f) Crane Load
- g) Collateral Load
- h) Auxiliary Load

**Longitudinal:** The direction parallel to the ridge line.

**Louver:** A wall opening provided with slanted blades, fixed or movable, to allow flow of air inside the building.

**Machine Bolts:** Mild steel bolts conforming to ASTM A307 standard specifications.

**Mastic:** See **Caulking**.

**Mezzanine:** An intermediate floor within a building above the ground floor that occupies all or part of the building floor area and consists of columns, beams, joists, deck panels and edge trims to receive reinforced concrete.

**Masonry:** Construction materials such as bricks, concrete blocks and stone.

**Moment:** The tendency of a force to cause rotation about a point or axis.

**Moment Connection:** A connection designed to transfer moment, as well as axial and shear forces, between connecting members.

**Monorail Beam:** A single beam support for a material handling system. It is normally a hot rolled "I" beam.

**Mono-Slope:** A building sloped in one direction.

**Mullion:** A vertical bar or pier between panes or sections of windows and screens.

**Multi-Gable Buildings:** Buildings consisting of one or more gables across the width of the building.

**Multi-Span Buildings:** Buildings with interior columns.

**Notch:** A rebate. See also **Concrete Notch**.

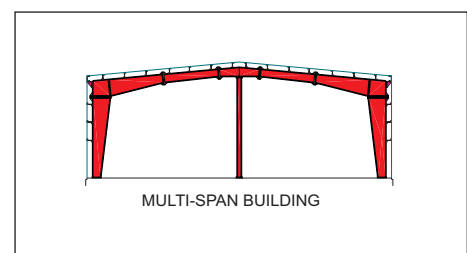
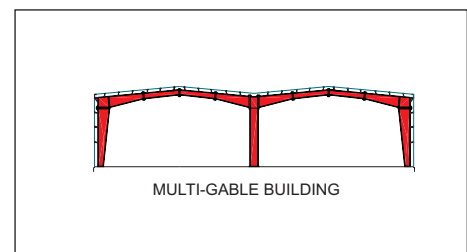
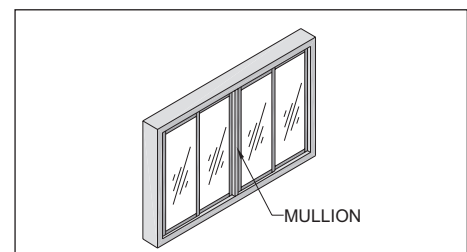
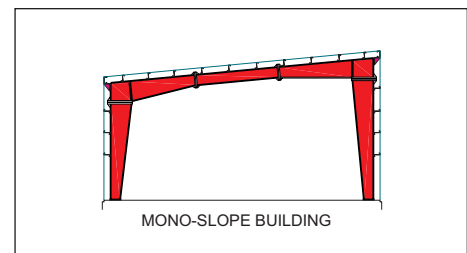
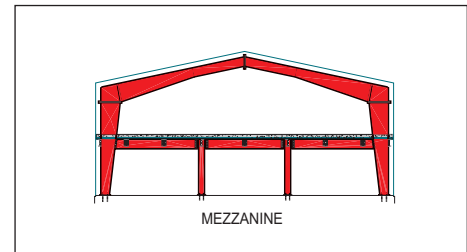
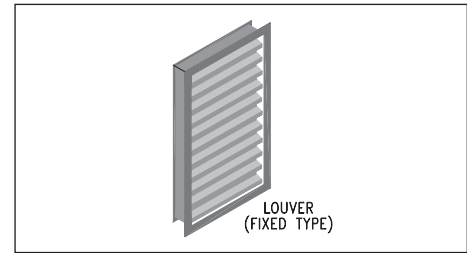

**Panel:** A piece of roof or wall sheeting. See also **Sheeting**.

**Parapet Wall:** That portion of the vertical wall which extends above the roof line at the intersection of the wall and roof.

**Part Mark:** A number physically marked on a piece or packing that identifies each component of the building for erection and shipping purposes.

**Partition:** A non-load bearing interior dividing wall. It can sustain its own weight but does not support the ceiling or roof and is designed to withstand a maximum lateral load of 0.25 kN/m<sup>2</sup>.

**Peak:** The uppermost point of a gable. Also called **Peak Point** or **Ridge Point**.

**Peak Panel:** Also known as **Ridge Panel**. Used to link and weather-seal roof panels on opposing slopes.

**Peak Sign:** A sign attached to the peak of the building at the endwall showing the name of the manufacturer of the building. Also called **Ridge Sign**.

**Personnel Door:** An access door.

**Pier:** A concrete structure designed to transfer the vertical load from the column base to the footing.

**Pilot Door:** A small access door within one leaf of a sliding door. Also called **Wicket Door**.

**Pin Connection:** A connection designed to transfer the axial and shear forces between connecting members, but not moment forces.

**Pinned Base:** A column base that is designed to resist horizontal and vertical movement, but not rotation.

**Pipe Flashing:** Used in sealing roof penetrations.

**Pitch (Hole):** Distance between center lines of holes along longitudinal axis of plate.

**Pitch (Roof):** Slope of the roof

**Plan:** Details of a building as viewed from the top.

**Pop Rivet:** Used for joining flashing and light gauge metal trims. See also **Blind Rivet**.

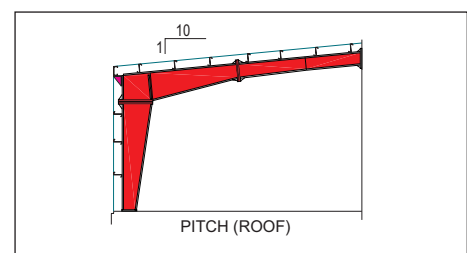
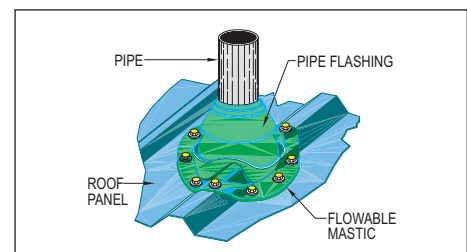
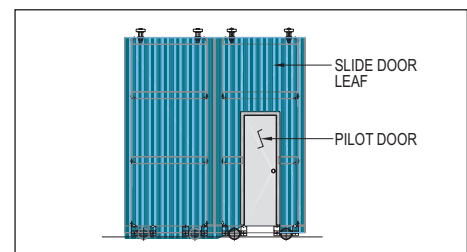
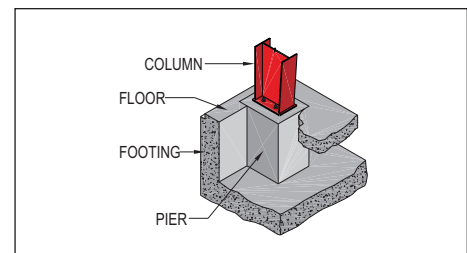
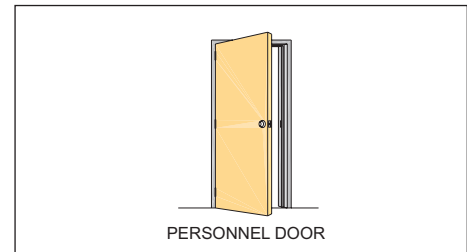
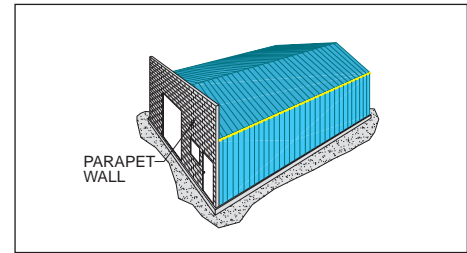

**Portal Frame:** Column and beam bracing used in lieu of standard diagonal cable bracing to provide clear access.

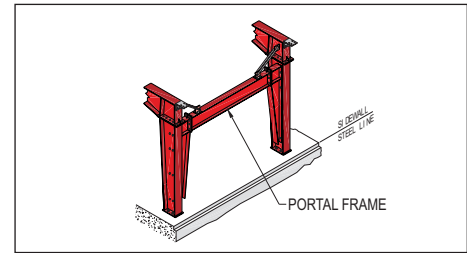

**Post-and-Beam Endwall:** A system of endwall framing consisting of vertical columns (posts), with pinned ends, which support rafters (beams). These posts and beams are normally light members made from cold-formed sections.

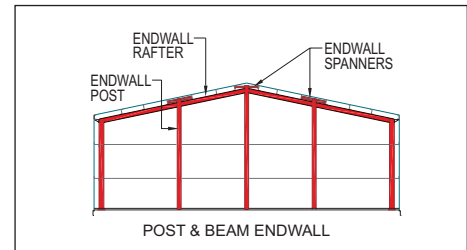

**Pre-Engineer:** To design and detail components beforehand.

**Pre-Fabricate:** To fabricate parts in the shop beforehand. To manufacture standard sections that can be rapidly assembled.

**Primary Framing:** The main load carrying members of a structural system, generally the columns, rafters, and/or other main support members.

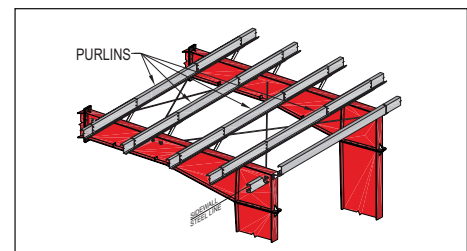

**Primer Paint:** The initial coat of paint applied in the shop to the structural framing of a building for protection against aggressive environmental conditions during shipping and erection.

**Purlin:** A horizontal secondary structural member, bolted to the rafters, which transfers the roof loads from the roof covering to the primary frames.

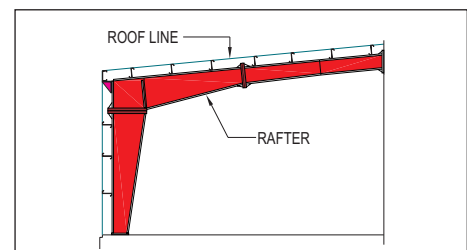

**Purlin Extension:** A projecting secondary member used in roof extensions at the endwall.

**Purlin Line:** The line joining the extreme outer, or exterior, edges of the purlins parallel to the frames.

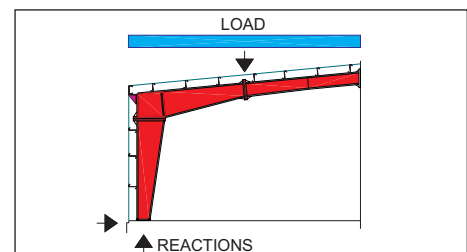

**Rafter:** A primary beam member supported on columns.

**Rake:** The intersection of the plane of the roof and the plane of the gable.

**Rake Trim:** The sheeting item joining the roof and wall sheeting at the rake. Also called **Gable Trim**.

**Reactions:** The resisting forces, at the column bases of a frame, holding the frame in equilibrium under a given loading condition.

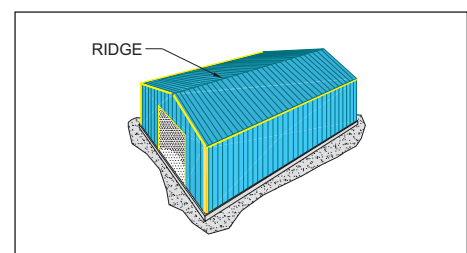

**Revision:** A change that is made to the building design, component details, location of accessories, etc.

**Ridge:** The peak, or highest point of a gabled building, which describes a horizontal line running the length of the building.

**Ridge Flashing:** Continuous metal flashing used to close roofing material along the ridge of a roof. Also called **Ridge Cap** or **Peak Panel**.

**Ridge Connection:** A connection, between two rafter members, which transfers the moment from one side of the connection to the other and maintains, under application of load, the same angle between the connected members that exists prior to the loading. See also **Moment Connection**.

**Ridge Sign:** The manufacturer's sign at the peak or highest point of the gable. Also called **Peak Sign**.

**Ridge Ventilator:** The ventilator used at the ridge line.

**Rigid Frame:** A structural frame consisting of members joined together with rigid (or moment) connections so as to render the frame stable with respect to imposed loads, without the need for bracing in its plane.

**Rigid Frame Endwall:** A system of endwall framing where the main interior frame is used at the endwall mostly for the purpose of future expansion.

**Risers:** The vertical rise of the steps of a staircase.

**Roll-Up Door:** A door which opens vertically and is supported on a shaft or drum and runs along vertical tracks.

**Roof Covering:** The exterior roof skin consisting of panels or sheets, their attachments, and weather sealant.

**Roof Curb:** Weatherproof flashing used on roofs to support power ventilators or ducting. Roof curbs can be fiberglass or sheet metal.

**Roof Extension:** An extension of the roof beyond the endwall and/or sidewall of a building.

**Roof Monitor:** Raised gable, or portion of the main building, located at the ridge, to allow lighting and ventilation.

**Roof Slope:** The angle that a roof surface makes with the horizontal. Usually expressed in units of vertical rise to 10 units of horizontal run.

**Sag Rod:** A tension member used to limit the movement of a girt or purlin in the direction of its weak axis before the installation of sheeting.

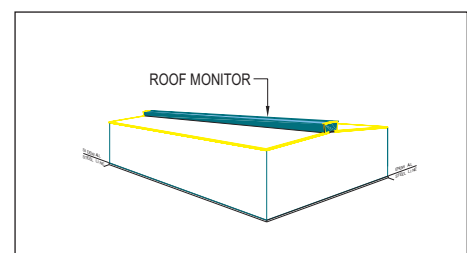
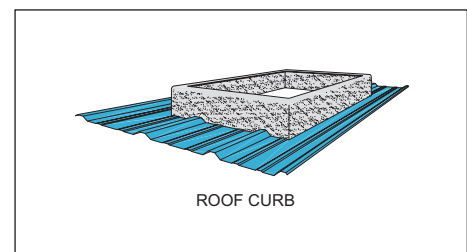
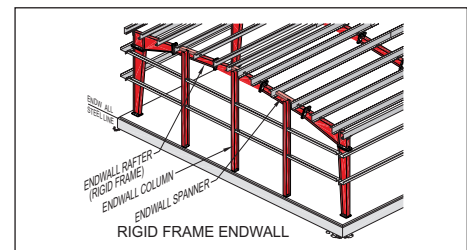
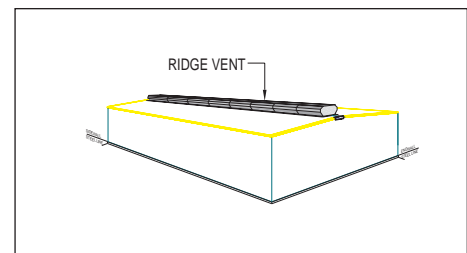
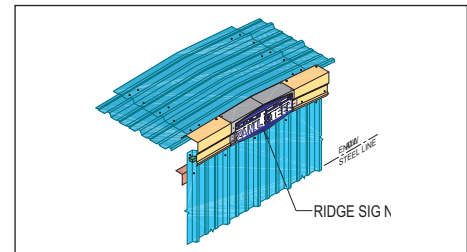
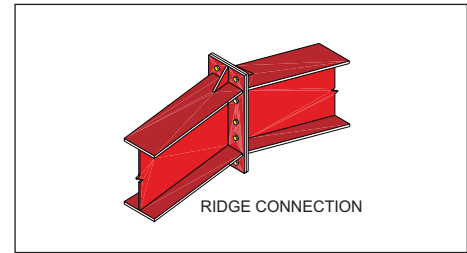

**Sealant:** See **Caulking**.

**Secondary Framing:** Members which carry loads to the primary framing. In metal buildings this term includes purlins, girts, eave struts, flange braces, etc.

**Seismic Load:** The assumed lateral load acting in any horizontal direction on the structural system due to earthquakes.

**Self Drilling Fasteners:** See **Self Drilling Screws**.

**Self Drilling Screws (SDS):** Fasteners, used for attaching panels and trims to girts and purlins, which drill their own holes and eliminate the pre-drilling operation.

**Self Tapping Screws (STS):** Have the same function as SDS but need pre-drilled holes.

**Sheeting:** Profiled metal panels.

**Sheeting Angle:** An angle used to support sheeting.

**Shims:** Small steel plates used for levelling base plates or for packing between structural members.

**Shipping List:** A list that enumerates, by part number or description, each piece of material or assembly to be shipped. Also known as **Packing List**.

**Shop Details:** Drawing details for fabrication of parts and assemblies.

**Side Lap:** A term used to describe the lap at the side or lengthwise direction of panels.

**Sidewall:** A term used to describe the entire composition of a building side which is parallel to the ridge.

**Sill:** The bottom horizontal member of a door or window opening.

**Simple Span:** The term used in structural engineering to describe a support condition, for a beam, girt, purlin, etc., which offers no resistance to rotation at the supports.

**Single Slope Building:** See also **Mono-Slope**.

**Skylight:** A translucent panel used at the roof to transmit natural light. It is usually made of fiberglass.

**Slats:** Flat strips used in the shutters of roll-up doors.

**Sleeve Nut:** A long nut normally used to join two brace rods of the same diameter together. Also known as **Coupling**.

**Sliding Door:** A single or double leaf door which opens horizontally by means of overhead trolleys or bottom wheels.

**Slot:** An elongated hole.

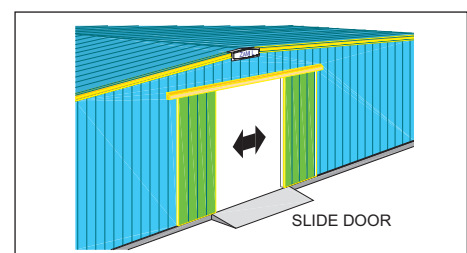
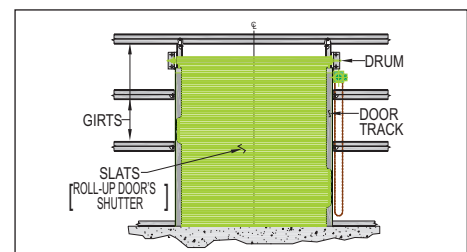
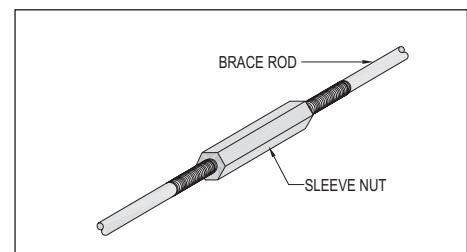
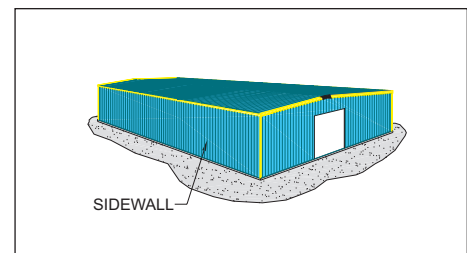
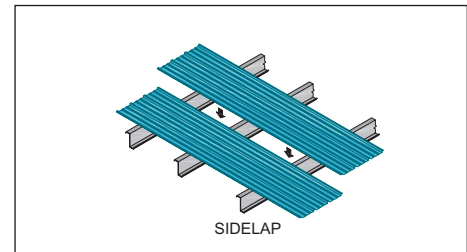
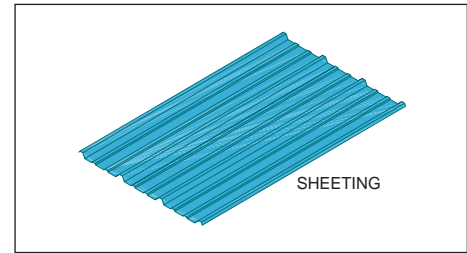

**Soffit:** The underside covering of any exterior portion of the metal building such as canopies, sidewall and endwall roof extensions.

**Soil Pressure:** The load, per unit area, a structure will exert, through its foundations, on the soil.

**Soldier Column:** A column, in sidewalls outside the main frame lines, located in extended bays to support sidewall girts, wall canopies and Lean-To's.

**Space Saver:** Building with a single gable clear span and straight columns. Wall girts are flush mounted.

**Span:** Distance between the supports of beams, girders or trusses. In a pre-engineered building distance between interior columns.

**Spanner:** A component used to connect the endwall post (column) to the endwall roof purlins.

**Specification:** A statement of particulars defining physical dimensions, strength and other properties, or a statement defining performance expectations of materials or devices.

**Splice:** The connection between two structural members.

**Steel Line:** The extreme outer limits of the structural framing system of a building to which the sheeting is attached.

**Step in Eave Height:** The condition where a lower building is attached to a higher building at the endwalls, resulting in one building with different eave heights at each end. Sometimes called **Roof Transition**.

**Stiffener:** Plate welded to a member to increase strength of the web or to provide continuity at connections.

**Stiffening Lip:** A short extension of material, at an angle to the flange of cold-formed structural members, which adds strength to the member.

**Stiles:** The vertical side members of a door frame.

**Stitch Screws:** Fasteners used to fasten side laps of panels and for attaching trims or flashing.

**Structural Steel Members:** Load carrying members. May be hot rolled sections, cold-formed shapes, or built-up sections.

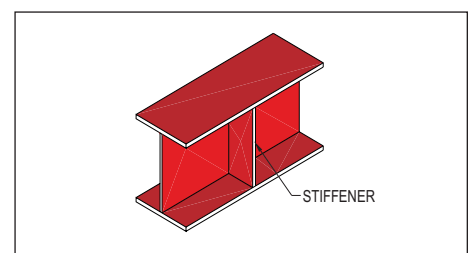
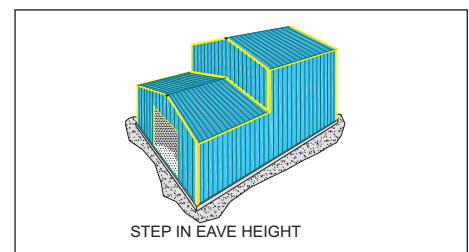
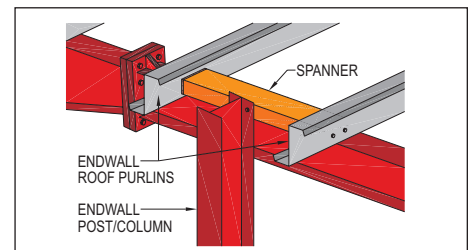
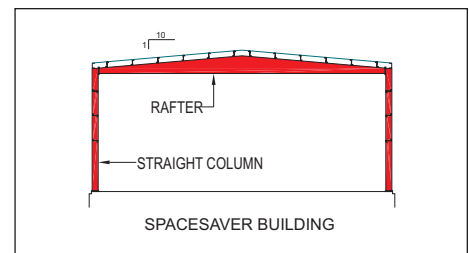
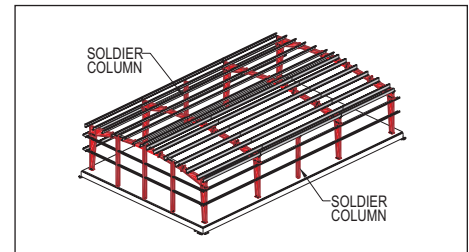
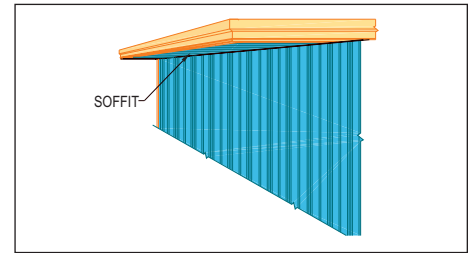

**Strut:** A brace fitted into a framework to resist force in the direction of its length.

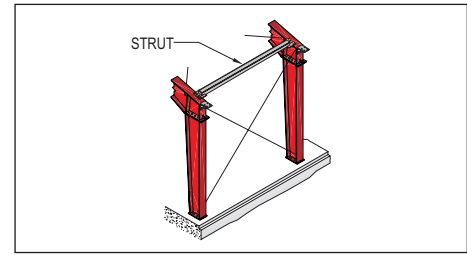

**Strut Purlin:** An additional purlin, in braced bays, located close to the normal purlin at the intersection of roof brace rods or cables and the frame rafter, as required by design.

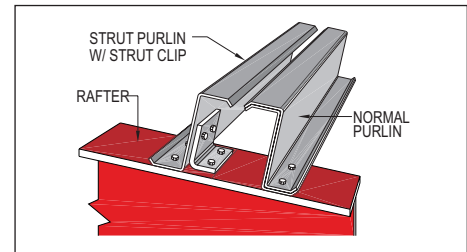

**Suction:** A partial vacuum, resulting from wind loads on a building, which causes a load in the outward direction.

**Tapered Member:** A built-up plate member consisting of flanges welded to a web of variable depth.

**Tempcon Panel:** A panel assembly consisting of an insulated core material sandwiched between an interior and exterior skin panel. Sometimes called **Sandwich Panel**.

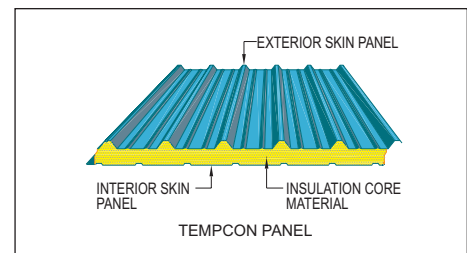

**Throat:** Minimum width of the ventilator air inlet.

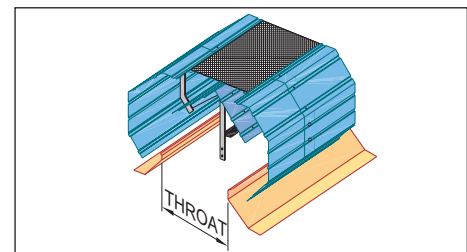

**Thrust:** A horizontal component of a reaction.

**Tolerance:** A fractional allowance for variations from the specified standard weight, dimensions, etc., of mechanical construction.

**Track:** A metal way for wheeled components, specifically one or more lines of ways, with fastenings, ties, etc., for a craneway, monorail or sliding door.

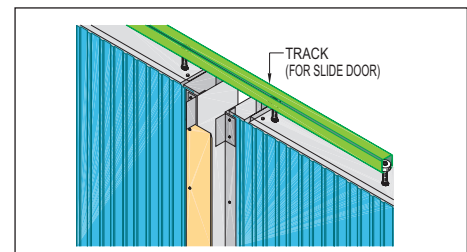

**Translucent:** Allowing the passage of light, but not permitting a clear view of any object. A translucent material is semi-transparent or semi-clear.

**Transverse:** From sidewall to sidewall of a building.

**Tread:** The horizontal step of a staircase.

**Trim:** Pre-formed light gauge metal used as a cover to cut edges, sides or junctions of sheeting.

**Truss:** A structural member, made up of several individual parts welded or bolted together, designed to carry a tension or compression force with the complete structure acting as a beam.

**Tube Column:** A vertical structural support member made of a hollow square tube. Normally used as an interior support column in Multi-Span buildings or mezzanine floors.

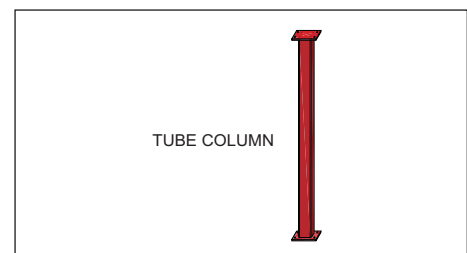

**Turn-of-Nut Method:** A method of tightening high strength bolts in accordance with AISC: "Specifications for Structural Joints using ASTM A325 Bolts".

**Under Hung Crane:** Bridge crane hanging from beams, rather than supported on beams.

**UL Rating:** Underwriters Laboratories certification rating for reliability and quality.

**Uniform Load:** Load that covers all or part of a beam or surface where, throughout the portion covered, the intensity of load per unit of length or area is the same.

**Uplift:** Wind load on a building which causes a load in the upward direction. See also **Suction**.

**Valley Gutter:** A channel used to carry off water, normally from roofs of multi-gabled buildings.

**Vapor Barrier:** Material used to retard the flow of vapor or moisture into walls and roofs and thus prevent condensation within them.

**Ventilation:** The process of changing the air within a building.

**Ventilator:** A means of providing air changes within a building.

**Wall Covering:** The exterior wall skin consisting of panels or sheets and their attachments, trims and weather sealants.

**Web:** That portion of a structural member between the flanges.

**Web Member:** A structural member vertically or diagonally interposed between the top and bottom chords of a truss.

**Wheel Base:** The distance between the two wheels of a crane along the crane beam.

**Wheel Load:** The maximum load which is transferred through the wheels of a crane to a crane beam.

**Width Extension:** A Lean-To connected at the sidewall of a main building and having a roof with the same slope and level of the main building. See **Lean-To**.

**Wind Column:** A vertical member supporting a wall system designed to withstand horizontal wind loads usually at endwalls.

**Wind Bent:** See **Portal Frame**.

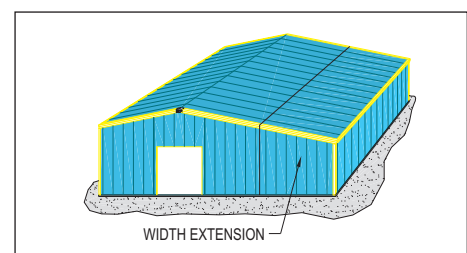
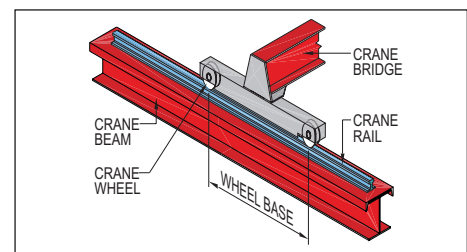
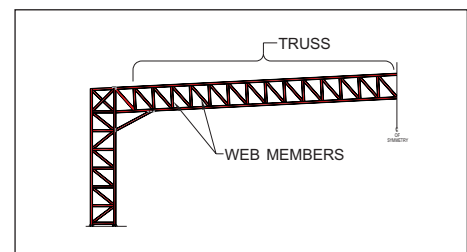
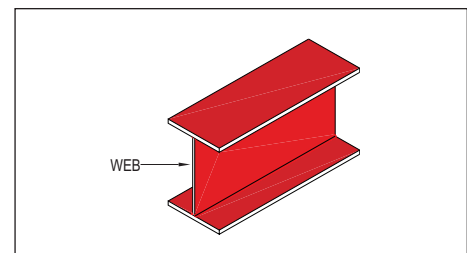
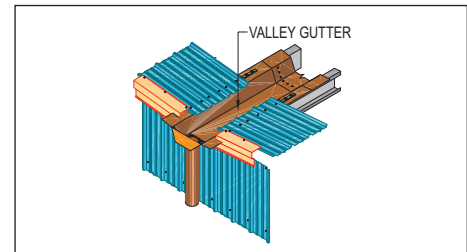
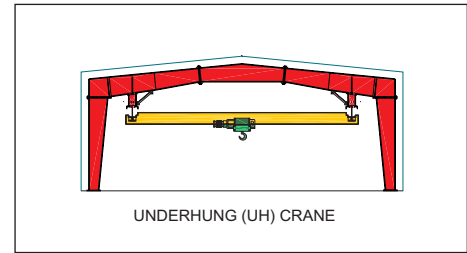



**Wind Load:** A loading representing the pressure exerted on a structure by a given wind velocity. A load caused by the wind blowing from any horizontal direction.

**“Z” Liner:** A liner which features a concealed fastener attachment with a flat surface profile. It is available in two profiles; Profile “D” (Sculptured) and Profile “E” (Flat).

**“Z” Section:** A member formed from coiled steel stock into the shape of a block “Z”. Usually used for purlins and girts.

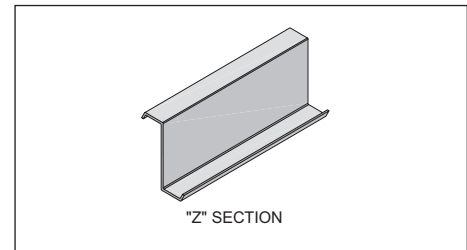
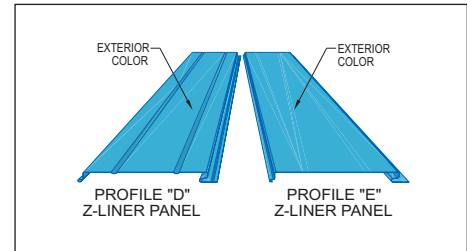

**Standard Abbreviations and Symbols**

<b>AB</b>	-	Anchor bolts
<b>ASSY</b>	-	Assembly
<b>Btu</b>	-	British thermal unit
<b>C</b>	-	Celcius
<b>C.O.</b>	-	Change order
<b>C/C</b>	-	Center to center
<b>CIF</b>	-	Contract information form
<b>CL</b>	-	Center line
<b>CONC.</b>	-	Concrete
<b>COL.</b>	-	Column
<b>COLL.</b>	-	Collateral
<b>CPU</b>	-	Customer pick-up
<b>CS</b>	-	Clear Span
<b>DET</b>	-	Detail
<b>dB</b>	-	Decibel
<b>DIM.</b>	-	Dimension
<b>DSD</b>	-	Double sliding door
<b>DWG</b>	-	Drawing
<b>EH(E.H.)</b>	-	Eave height
<b>ES</b>	-	Eave strut
<b>EW</b>	-	Endwall
<b>F</b>	-	Fahrenheit
<b>FFL(F.F.L.)</b>	-	Finished floor level
<b>FO(F.O.)</b>	-	Framed opening
<b>FNB</b>	-	Fin neck bolt
<b>HSB</b>	-	High strength bolt (ASTM A325)
<b>INT</b>	-	Internal or interior
<b>KD</b>	-	Knocked-down
<b>K</b>	-	Kelvin
<b>kg/cm<sup>2</sup></b>	-	Kilogram per square centimeter
<b>kg/m<sup>3</sup></b>	-	Kilogram per cubic meter
<b>km/h</b>	-	Kilometer per hour
<b>kN</b>	-	Kilonewton
<b>kN/m<sup>2</sup></b>	-	Kilonewton per square meter
<b>L</b>	-	Length
<b>L/C</b>	-	Letter of credit
<b>LG</b>	-	Long
<b>LT</b>	-	Lean-To
<b>m</b>	-	Meter
<b>M.T.</b>	-	Metric ton
<b>MAX. (max.)</b>	-	Maximum
<b>MG</b>	-	Multi-Gable

<b>MIN. (min.)</b>	-	Minimum
<b>mm</b>	-	Millimeter
<b>MR</b>	-	Monorail crane
<b>MSB</b>	-	Mild steel bolt or machine bolt
<b>N</b>	-	Newton
<b>NS/FS</b>	-	Near side / Far side
<b>OA</b>	-	Overall
<b>OC(O.C)</b>	-	On center
<b>O/O</b>	-	Out-to-out
<b>P &amp; B</b>	-	Post-and-Beam
<b>PL</b>	-	Plate
<b>REV.</b>	-	Revision
<b>RF(R.F.)</b>	-	Rigid frame
<b>RUD</b>	-	Roll-up door
<b>SBO(S.B.O.)</b>	-	Special buy out
<b>SDS</b>	-	Self drilling screw
<b>SF</b>	-	Space frame
<b>SI</b>	-	International System of Units
<b>SS</b>	-	Single Slope
<b>SSD</b>	-	Single sliding door
<b>STD.</b>	-	Standard
<b>STS</b>	-	Self tapping screw
<b>SV</b>	-	Space Saver
<b>SW</b>	-	Sidewall
<b>TC</b>	-	Tempcon panel
<b>THK(T)</b>	-	Thickness
<b>TRC</b>	-	Top running crane
<b>TYP</b>	-	Typical
<b>TYP UN</b>	-	Typical unless noted
<b>UHC</b>	-	Underhung crane
<b>W</b>	-	Watt or width
<b>W/</b>	-	With
<b>W/O</b>	-	Without
<b>WG</b>	-	Weatherguard (Panel)
<b>Wt.</b>	-	Weight
<b>ZS</b>	-	Zamil Steel
<b>∠</b>	-	Diameter
<b>@</b>	-	At
<b>#</b>	-	Number
<b>%</b>	-	Percentage

### Standard Colors & Finishes

<b>AB</b>	-	Arabian Beige
<b>BB</b>	-	Bronze Brown
<b>CG</b>	-	Cactus Green
<b>DG</b>	-	Desert Gold
<b>FW</b>	-	Frost White
<b>PVF2</b>	-	Polyvinylidene Flouride
<b>SB</b>	-	Shasta Blue
<b>TC</b>	-	Terra Cotta
<b>XPD</b>	-	Exterior Premium Durability
<b>XRW</b>	-	Exterior Roofing and Walling
<b>XSE</b>	-	Exterior Severe Environments
<b>Z/A</b>	-	Zincalume

### Standard Panel Profiles

<b>Profile “A”</b>	-	High-Rib panel
<b>Profile “B”</b>	-	High-Rib Plus panel
<b>Profile “C”</b>	-	Low-Rib panel
<b>Profile “D”</b>	-	Sculptured “Z”-Liner panel
<b>Profile “E”</b>	-	Flat “Z”-Liner panel
<b>Profile “F”</b>	-	5-Rib panel
<b>Profile “G”</b>	-	Deep-Rib panel
<b>Profile “R”</b>	-	“R” panel
<b>TCHR</b>	-	Tempcon High-Rib Sandwich panel
<b>TCLR</b>	-	Tempcon Low-Rib Sandwich panel
<b>TCMD</b>	-	Tempcon Modified Sandwich panel

### Codes, Specifications and Standards

<b>ACI</b>	-	American Concrete Institute
<b>AISC</b>	-	American Institute of Steel Construction
<b>AISI</b>	-	American Iron and Steel Institute
<b>ANSI</b>	-	American National Standard Institute
<b>AS</b>	-	Australian Standard
<b>ASCE</b>	-	American Society of Civil Engineers
<b>ASTM</b>	-	American Society for Testing and Materials
<b>AWS</b>	-	American Welding Society
<b>BS</b>	-	British Standard (Institute)
<b>DIN</b>	-	Deutsches Institut für Normung e. V. (German Institute for Standardization)
<b>EN</b>	-	Europe Standards
<b>ISO</b>	-	International Organization for Standardization
<b>JIS</b>	-	Japanese Industrial Standards
<b>MBMA</b>	-	Metal Building Manufacturers Association
<b>SSPC</b>	-	Steel Structures Painting Council
<b>UBC</b>	-	Uniform Building Code
<b>UL</b>	-	Underwriters Laboratories Inc.

# ENGINEERING PRACTICES

# C H A P T E R 3

# 3. Engineering Practices

3.1	General .....	55
3.2	Design Codes and Building Codes .....	56
3.3	Design Loads .....	57
3.4	Collateral Loads .....	59
3.5	Mezzanine Live Loads .....	60
3.6	Building Material Weights .....	61
3.7	Conversion Factors .....	62
3.8	Deflection Criteria .....	64
3.9	Engineering Output .....	65
3.10	Building Design Certification .....	67

Since its establishment in 1977, Zamil Steel has aggressively pursued complex engineering projects and has taken an active role in converting complex buildings designed with conventional structural steel into simpler and more economical pre-engineered steel buildings without sacrificing the utility and function of these buildings.

In its quest to become the engineering leader in the pre-engineered steel building industry, Zamil Steel has pioneered notable advancements in software development and computerization. Today, Zamil Steel is the only PEB company in the world where all professional staff are equipped with a state-of-the-art computer and where 100% of the engineering output (design calculations, erection drawings, shop details and bills of material) is produced in digital format.

In-house developed programs include the following proprietary software :

- **ASFAD** (Advanced Steel Frame Analysis and Design)
- **AGOSED** (Automatic Generator of Shop and Erection Drawings)
- **INTELEST** (Intelligent Building Estimator)



This brief chapter is intended to highlight the following :

- The standard design codes and building codes to which Zamil Steel designs.
- Zamil Steel's recommended deflection limitations.
- Description and scope of Zamil Steel engineering output.

This chapter should be read in conjunction with the following Zamil Steel publications :

- Standard Product Specifications
- Panel Chart (colors & profiles)

The latest edition of the above publications may be requested from the Marketing Department at Zamil Steel Head Office or from any Zamil Steel Area Office.

Zamil Steel follows universally accepted codes of practice in the analysis, design and fabrication of its pre-engineered buildings.

Zamil Steel is familiar with and is capable of designing and fabricating in accordance with many accepted international codes including, but not limited to *European Norms (EN)*, *British Standards (BS)*, *German Standards (DIN)*, *Uniform Building Code (UBC)*, *American National Standard Institute (ANSI)*.

We prefer to follow the following codes due to their wide usage in the U.S.A. where the PEB industry designs, manufactures and erects over 250,000 pre-engineered steel buildings every year.

It is Zamil Steel's policy to comply with the latest issues, supplements or addenda of these codes.



**Metal Buildings Manufacturers Association (MBMA)**  
1996 Low Rise Building Systems Manual 1300 Summer Ave. Cleveland, Ohio 44115

This manual is the authoritative guide for the design and manufacture of pre-engineered steel buildings.



**American Iron and Steel Institute (AISI)**  
Cold Formed Steel Design Manual, 1986 Edition / 1989 Addendum  
1000 16th Street, NW Washington, DC 20036

This manual is used to design cold-formed sections.

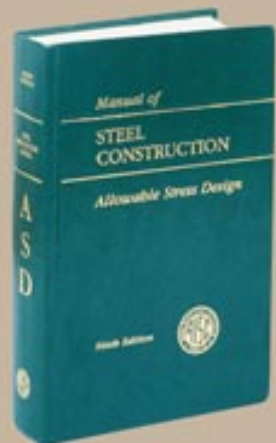

**American Institute of Steel Construction (AISC)**  
Manual of Steel Construction-Allowable Stress Design, 1989 Edition  
1 East Wacker Drive, Suite 3100 Chicago, Illinois 60601-2001

This manual is used to design built-up sections, hot rolled sections and welded plates and for the design of bolted connections.

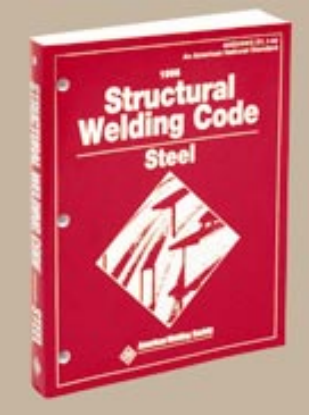

**American Welding Society (AWS)**  
Structural Welding Code - Steel, 1996 Edition, ANSI/AWS D1.1-96  
550 N.W. LeJeune Road Miami, FL 33126

This manual is used to design welded connections and to establish welding specifications and procedures.



As a minimum requirement, a building must be designed to support its own dead load, a specified live load and a specified wind load.

Other loads such as collateral loads, crane loads, seismic loads, mezzanine loads or thermal loads are considered only when specified by the customer.

1. *Dead load* is defined as the total weight of the building and its components. This includes main frames, purlins, girts, cladding, bracing, connections, etc.
2. *Live load* includes all loads that the structure is subjected to during erection, maintenance and usage throughout the life time of the structure. The live load is specified by the applicable building code for which the structure is designed.

Unless otherwise specified, Zamil Steel designs buildings for a minimum roof live load of 0.57 kN/m<sup>2</sup> as recommended in the 1986 Edition / 1990 Supplement of the “Low Rise Building Systems Manual” of the Metal Building Manufacturers Association (MBMA).

3. *Snow load* is the load resulting from the accumulation of snow on the roof. Snow loads depend on the geographic area where the building is located and the intensity of snow fall in that area. Snow load and roof live load should not be combined when considering vertical loads.
4. The application of *wind load* to a structure varies from one code of practice to another. For wind load design, Zamil Steel uses the “1996 Low Rise Building Systems Manual” of the Metal Building Manufacturers Association (MBMA). The concept is summarized as follows:

A basic wind speed is specified from which a velocity pressure is calculated. This velocity

pressure and a peak combined pressure coefficient are used to determine the design wind pressure according to the following equation:

$$q = 2.456 \times 10^{-5} V^2 H^{2/7}, \quad \text{where}$$

$q$  = velocity pressure in kilonewton per square meter (kN/m<sup>2</sup>).

$V$  = specified basic wind speed in kilometers per hour (km/h).

$H$  = mean roof height above ground in meters (m). ( $H$  must be greater than or equal to 4.6 m.)

Note: Eave height may be used instead of mean roof height if roof slope is not greater than 10° (1.76:10).

5. *Collateral load* is the weight of additional materials permanently fixed to the building (other than the dead load and the live load of the building) such as fire sprinklers, mechanical systems, electrical systems, false ceilings, partitions, etc.
6. *Crane load* is calculated in accordance with Section 6 of the “1996 Low Rise Building Systems Manual” of the Metal Building Manufacturers Association (MBMA). Crane loads and their corresponding vertical, lateral and longitudinal impacts are applied in accordance with the above noted section.
7. *Seismic load* is caused by earthquake forces and is applied horizontally at the center of mass of the main structure.

In pre-engineered buildings that do not contain heavy internal structural subsystems, such as mezzanines and crane systems, the horizontal seismic force is normally applied at the eave of these buildings.

In pre-engineered buildings with mezzanines and/or crane systems, the horizontal seismic force resulting from each system will be applied at the center of mass of that system.

The structure is designed and constructed to resist a minimum total lateral seismic force (assumed to act non-concurrently in the direction of each of the main axes of the structure) in accordance to the following formula:

$$V = 0.14ZKW, \quad \text{where}$$

$V$  = total lateral seismic force or shear at the base in kN.

$Z$  = numerical coefficient corresponding to the seismic zone in which structure is sited, 3/16 for zone 1, 3/8 for zone 2, 3/4 for zone 3 and 1.0 for zone 4.

$K$  = 1.0 for a moment resisting frame. (This typically applies to pre-engineered buildings)

= 1.33 for a braced frame or shear wall.

$W$  = total dead load, including collateral loads and partitions, and a portion of the building live load specified by the code according to the usage classification of the building.

For more information, consult the “1996 Low Rise Building Systems Manual” of the Metal Building Manufacturers Association (MBMA).

8. *Mezzanine load* is the *dead load* of the mezzanine framing, including all finishes, in addition to the *live load* applied on the mezzanine according to its occupancy and usage classification.

Where mezzanine live loads are not specified by the customer, the live loads shall be as

recommended in Table 8.1 of the “1996 Low Rise Building Systems Manual” of the Metal Building Manufacturers Association (MBMA). “Some most frequently used mezzanine live loads are listed in **section 3.5**. Typical dead loads are listed in **section 3.6**.”

When partitions are installed on a mezzanine, it is important to specify their type, weight and exact location.

9. *Thermal load* is the load introduced into structural members as a result of temperature variations. Thermal loads increase the unit stresses in the members. This increase in unit stress is calculated from the following formula:

Changes in unit stress =  $E e t$ , where

$E$  = Modulus of elasticity of steel  
= 20340 kN/cm<sup>2</sup>

$e$  = Coefficient of thermal expansion  
= 0.0000117 for each degree Celsius

$t$  = Difference in temperature in degrees Celsius.

*Collateral loads* can be uniformly distributed or concentrated. Collateral loads result from permanent installations inside the building that are planned and used to provide the functions of the building such as false ceiling, lighting, ventilation, AC ducting, piping, electrical installation, etc. It is recommended to plan the connection of such installations so that they result in uniformly distributed loads and minimize the concentrated loads. This is due to the fact that

distributed loads impose a more uniform effect on frames, and thereby provides greater flexibility in locating points of suspension.

The most common collateral loads normally applied to pre-engineered steel building are:



Description	Uniform Load (kN/m <sup>2</sup> )
Suspended ceiling (framing and tiles)	0.05
Roof metal liner panel	0.05
Heating / air conditioning ducting	0.10
Lighting	0.05
Fire sprinkler system	0.15

In the absence of actual load data, the following live loads, extracted from Table 8.1 of the “1996 Low Rise Building Systems Manual” of MBMA,

are assumed by Zamil Steel when designing mezzanine structures:

Type of Building	Type of Occupancy	Live Load (kN/m <sup>2</sup> )
Assembly Halls	With Fixed Seats	2.50
	With Movable Seats	5.00
	Stage Floor	7.50
Gymnasiums	Main Floor	5.00
Libraries	Reading Rooms	3.00
	Stack Rooms	7.50
Manufacturing Facilities	Light	5.00
	Heavy	7.50
	Maintenance Platforms	3.00
Office Buildings	Offices	2.50
	Lobbies	5.00
	Computer Rooms	5.00
	Corridors above first floor	4.00
Schools	Class Rooms	2.00
	Corridors	4.00
	Recreation Rooms	3.75
Warehouses	Light	6.25
	Heavy	12.50
Shopping Stores	Retail	3.75
	Wholesale	5.00
Stairs and Exitways		5.00

The weights of the most common building materials are given in the table below:

Category	Material		Weight (kg/m <sup>2</sup> )
Floors	Terrazzo tile	25 mm thick	65
	Ceramic or quarry tile	20 mm thick	50
	Linoleum or vinyl	6 mm thick	5
	Mastic	20 mm thick	45
	Hardwood	20 mm thick	18
	Softwood	20 mm thick	12.5
Partitions	Clay tile	75 mm thick	85
		100 mm thick	90
		150 mm thick	140
		200 mm thick	170
		250 mm thick	200
	Gypsum board	50 mm thick	47.5
		75 mm thick	52.5
		100 mm thick	62.5
		125 mm thick	70
		150 mm thick	92.5
Roofs	Built-up	3-ply ready roofing	5
		3-ply felt and gravel	27.5
		5-ply felt and gravel	30
	Shingles	Wood	10
		Asphalt	15
		Clay tile	45 - 70
		Slate (6 mm thick)	50
	Sheathing	Wood (20 mm thick)	15
		Gypsum (25 mm thick)	20
		Insulation (per 25 mm thickness)	Loose
	Poured-in-place		10
	Rigid		7.5
Walls	Bricks	100 mm thick	200
		200 mm thick	400
		300 mm thick	600
	Hollow concrete block (heavy aggregate)	100 mm thick	150
		150 mm thick	215
		200 mm thick	275
	Hollow concrete block (light aggregate)	300 mm thick	400
		100 mm thick	105
		150 mm thick	150
	Clay tile Load Bearing	200 mm thick	190
		300 mm thick	275
		100 mm thick	125
	Plastering (25 mm thick)	150 mm thick	150
		200 mm thick	165
		300 mm thick	225
	Stone	Cement	50
		Gypsum	25
	Structural glass	(100 mm thick)	275
	Corrugated asbestos	(25 mm thick)	75
		(6 mm thick)	15

The table below contains some of the most commonly used conversion factors.

<b>Length</b>	Mile (mi)	1.609 kilometer (km)
	Yard (yd)	0.914 meter (m)
	Foot (ft)	0.304 meter (m)
		304.8 millimeter (mm)
	Inch (in)	25.4 millimeter (mm)
	Mil (mil)	25.4 microns ( $\mu\text{m}$ )
<b>Area</b>	Square mile ( $\text{mi}^2$ )	2.590 square kilometer ( $\text{km}^2$ )
	Acre (ar)	4047 square meter ( $\text{m}^2$ )
	Square yard ( $\text{yd}^2$ )	0.836 square meter ( $\text{m}^2$ )
	Square foot ( $\text{ft}^2$ )	0.093 square meter ( $\text{m}^2$ )
	Square inch ( $\text{in}^2$ )	645.2 square millimeter ( $\text{mm}^2$ )
<b>Volume</b>	Cubic yard ( $\text{yd}^3$ )	0.765 cubic meter ( $\text{m}^3$ )
	Cubic foot ( $\text{ft}^3$ )	0.028 cubic meter ( $\text{m}^3$ )
	Cubic inch ( $\text{in}^3$ )	16390 cubic millimeter ( $\text{mm}^3$ )
		16.39 milliliter (ml)
	U.S. gallon (gal)	3.785 liters (l)
<b>Velocity, Speed</b>	Foot per second (ft/s)	0.305 meter per second (m/s)
	Mile per hour (mi/h)	1.609 kilometer per hour (km/h)
		0.447 meter per second (m/s)
<b>Mass</b>	Short ton (2000 lb)	0.907 metric ton (M.T.)
		907.2 kilogram (kg)
	Pound (lb)	0.454 kilogram (kg)
	Ounce (oz)	28.35 gram (g)



<b>Pressure</b>	Pound per square foot (lb/ft <sup>2</sup> )	4.883 kilogram per square meter (kg/m <sup>2</sup> )
		47.88 newton per square meter (N/m <sup>2</sup> )
<b>Density</b>	Pound per cubic foot (lb/ft <sup>3</sup> )	16.02 kilogram per cubic meter (kg/m <sup>3</sup> )
	Ton per cubic yard (ton/yd <sup>3</sup> )	1.187 metric ton per cubic meter (M.T./m <sup>3</sup> )
<b>Force</b>	Ton-force (tonf)	8.896 kilonewton (kN)
	KIPS (KIP)	4.448 kilonewton (kN)
	Pound-force (lbf)	4.448 newton (N)
<b>Moment or Torque</b>	Pound-force-foot (lbf.ft)	1.356 newton-meter (N.m)
	Pound-force-inch (lbf.in)	0.113 newton-meter (N.m)
	KIPS-foot (KIP.ft)	1.356 kilonewton-meter (kN.m)
<b>Force per Unit Length</b>	Pound per foot (lb/ft)	14.59 newton per meter (N/m)
<b>Stress</b>	KIPS per square inch (ksi)	0.690 kilonewton per square centimeter (kN/cm <sup>2</sup> )
<b>Work, Energy &amp; Heat</b>	British thermal unit (Btu)	1055 joules (J)
	Pound-foot (lbf.ft)	1.356 joules (J)
<b>Heat Transfer</b>	British thermal unit per square foot hour degree fahrenheit (Btu/ft <sup>2</sup> hr.°F)	5.678 watt per square meter kelvin (W/m <sup>2</sup> .K)
<b>Thermal Conductivity</b>	British thermal unit per foot hour degree fahrenheit (Btu/ft. hr.°F)	1.731 watt per meter kelvin (W/m.K)

Standard codes of practice do not establish clear or rigid criteria for limiting the deflection of structural members, this decision is left to the judgment of the professional design engineer.

Zamil Steel, based upon its extensive building

design experience, has adopted a conservative policy for defining deflection criteria.

The following table specifies the deflection limitations used by Zamil Steel for the various structural members used in Zamil Steel buildings.

Deflection		Structural Member	Deflection Limitation	Load Combination
<b>Vertical Deflection</b>	1	Main frame rafters	Span/ 180	Dead + Live
	2	Roof purlins	Span/ 180	Dead + Live
	3	Mezzanine beams and joists	Span/ 240	Dead + Live
	4	Top running crane (TRC) beams	Span/ 600	Dead + Crane
	5	Underhung crane (UHC) beams	Span/ 500	Dead + Crane
	6	Monorail crane (MR) beams	Span/ 500	Dead + Crane
	7	Relative deflection of adjacent frames at point of support of UHC or MR beam.	Bay/225	Crane only
	8	Relative deflection of UHC beams supported by the same frame.	Crane span/ 500	Crane only
	9	Rigid frame rafters supporting UHC or MR beams running laterally in the building.	Bldg. span/ 500	Crane only
<b>Lateral Deflection</b>	1	Main frame columns with eave height (EH) up to 9.0 m	Eave height/45	Dead + Wind
	2	Main frames supporting top running cranes (TRC) or underhung cranes (UHC)	Eave height/60	All
	3	Wall girts	Span/ 120	Wind only
	4	Endwall wind columns	Span/ 120	Wind only
	5	Portal frames	Eave height/45	Wind only



The Engineering Department produces the documents required for the approval, fabrication and erection of the building. The Engineering Department can provide those documents in a printed format or in electronic format (computer files or CD-ROM) upon the customer request.

Engineering output consists of the following :

- Approval drawings (optional)
- Design calculations
- Anchor bolt plans
- Erection drawings
- Shop details
- Bill of materials (BOM)

Shop details are internal documents intended for Zamil Steel factory use only and are not circulated outside Zamil Steel.

### **Approval Drawings (Optional)**

The approval drawings package consists of the following (for each building) :

- Anchor bolt plan
- Frame cross-section
- Roof and wall framing
- Roof and wall elevations
- Location of building accessories
- Important notes

Approval drawings shall be submitted upon request. If approval drawings are requested, fabrication shall not start until one set of the approval drawings has been signed by the customer or his representative “**Approved As Is**” or “**Approved As Noted**” and returned to Zamil Steel. The customer is responsible to check all information thoroughly and add his



comments (if any) on the drawings. Notes on the returned approval drawings must be specific and legible. Non specific and open ended remarks such as “what”, “why”, question marks, exclamation marks, etc. should be avoided as they do not contribute to the resolution of the intended query.

When the customer’s notes are accepted by Zamil Steel, the approval package becomes binding on both parties. Waiver of approval drawings for simple buildings expedites the fabrication and delivery of the building(s).

Approval drawings should not be used for construction or for civil works design.

### **Design Calculations**

Design calculations consist of the structural analysis and design of all the primary and secondary structural members of a building and are submitted only when specifically requested by the customer. Design calculations are intended for reference only; customer approval of design calculations is not required by Zamil Steel.

### **Anchor Bolt Plans**

Anchor bolt plans are submitted after all technical matters are finalized. They are “**Issued For Construction**” drawings and are intended to enable the customer to proceed with civil work foundations in preparation for the delivery of the pre-engineered steel building. Anchor bolt plans are put in erection drawings

Anchor bolt plans contain :

- Size and quantity of anchor bolts and their exact location.
- Dimensions of all column bases.
- Column reactions for all main and secondary columns.

- Door (sliding, roll up, personnel, etc.) fixing details.
- Recommended drainage outlet locations.

During the execution of civil works, anchor bolt plans must be fully complied with to avoid fitting problems during erection.

### **Erection Drawings**

Erection drawings are final “**Issued For Construction**” drawings. They show the installed locations of every component of a building. Erection drawings identify the **part marks** (usually factory stamped on the steel members) of all the components of the pre-engineered building.

Like anchor bolts plans, erection drawings must be followed precisely by the erector in order to result in a quality building.

### **Bill of Materials (BOM)**

This is a list of all the components used in a building and their respective quantities. It is used to verify the quantities received in the delivery packing lists and corresponds to the quantities shown on the erection drawings.



Often a government building authority requires the buyer of a pre-engineered steel building to furnish a building design certificate to attest the design adequacy of the steel building. Zamil Steel can

furnish such a certification, signed and stamped by a U.S. registered professional engineer, at no cost to the buyer. An example of a **Building Design Certification** is shown below.

**ZAMIL STEEL BUILDINGS**  
**Head Office**  
 P.O. Box 270 Dhahran Airport 31932 Saudi Arabia  
 Phone (966 3) 857 1840 • Fax 857 1291 • Telex 801414  
 Industrial Licence No. 68 Dated 11-1-1415 H. C.R. 2050004215  
 Limited Liability Company Paid up capital 28,500,000 Saudi Riyals

**الزامل للمباني الحديدية**  
 المكتب الرئيسي  
 ص.ب. ٢٧٠ مطار الظهران ٣١٩٣٢ المملكة العربية السعودية  
 هاتف: ٨٥٧ ١٨٤٠ • فاكس: ٨٥٧ ١٢٩١ • تليكس: ٨٠١٤١٤  
 ترخيص صناعي رقم ٦٨ تاريخ ١١-١-١٤١٥ هـ س.ت ٢٠٥٠٠٠٤٢١٥  
 شركة ذات مسئولية محدودة رأس المال المذخور ٢٨.٥٠٠.٠٠٠ ريال سعودي

**Customer Name** \_\_\_\_\_  
**Address** \_\_\_\_\_

**Subject :** Building Design Certificate

**Reference :** Zamil Steel Job No. \_\_\_\_\_

Dear Sirs,

The building(s) in the above referenced job has/have been designed to withstand the following loads:

Live Load on roof panels	=	_____	kN/m <sup>2</sup>	
Live Load on roof purlins	=	_____	kN/m <sup>2</sup>	
Live Load on frames	=	_____	kN/m <sup>2</sup>	
Wind Speed	=	_____	km/h	
Dead Load	=	_____	kN/m <sup>2</sup>	(Total self weight of structure and components)
Collateral Load	=	_____	kN/m <sup>2</sup>	

- The above loads have been applied on the structure in accordance with:  
 MBMA "Metal Building Manufacturers Association"  
 Low Rise Building Systems Manual, 1986 Edition/1990 Supplement.  
 1230 Keith Building, Cleveland, Ohio 44115.
- Hot rolled section and built-up components have been designed in accordance with:  
 AISC "American Institute of Steel Construction"  
 Manual of Steel Construction - Allowable Stress Design, 1989 Edition  
 1 East Wacker Drive, Suite 3100, Chicago, Illinois 60601 - 2001
- Cold-formed components have been designed in accordance with:  
 AISI "American Iron and Steel Institute"  
 Cold Formed Steel Design Manual, 1986 Edition/1989 addendum.  
 1000 16<sup>th</sup> Street, NW, Washington, DC 20036
- Welding has been performed in accordance with:  
 AWS "American Welding Society"  
 ANSI/AWS D1.1-96 Structural Welding Code - Steel, 1996 Edition.  
 550 N.W. Lejeune Road, Miami, FL33126

**Phone :** \_\_\_\_\_  
**Fax :** \_\_\_\_\_  
**Date :** \_\_\_\_\_

Sincerely yours,  
  
**MOHAMMED H. AL-YOUSIF, P.E.**  
 Engineering Manager  
 Pre-Engineered Buildings Division

cc: SSD, Job file

- Area Offices**
- Saudi Arabia (Dammam, Riyadh, Jeddah) ● Kuwait ● Bahrain (Manama) ● Qatar (Doha) ● United Arab Emirates (Dubai & Abu Dhabi)
  - Oman (Muscat) ● Yemen (Sanaa) ● Jordan (Amman) ● Czech Republic (Prague) ● Romania (Bucharest) ● Lebanon (Beirut) ● India (Chennai)
  - Pakistan (Lahore) ● Sri Lanka (Colombo) ● Bangladesh (Dhaka) ● USA (Houston) ● Greece (Athens) ● France (Paris) ● Poland (Warsaw)
  - Egypt (Cairo & Alexandria, Port Saeed Assuit) ● Sudan (Khartoum) ● Ethiopia (Addis Ababa) ● Ghana (Accra) ● South Africa (Johannesburg)
  - Thailand (Bangkok) ● Myanmar (Yangon) ● Vietnam (Ho Chi Minh City & Hanoi) ● China (Shanghai) ● Philippines (Manila) ● Korea (Seoul)



# STANDARD STRUCTURAL SYSTEMS

# C H A P T E R 4

# 4. Standard Structural Systems

4.1	General .....	71
4.2	Clear Span Buildings .....	72
4.3	Multi-Span Buildings .....	74
4.4	Space Saver Buildings .....	77
4.5	Lean-To Buildings .....	78

In this Chapter the term “standard” refers to the most common and most economical **structural systems** supplied by Zamil Steel. More than 80% of the pre-engineered steel buildings supplied by Zamil Steel utilize one of the standard structural systems mentioned in this chapter. The other 20% utilize the “other” structural systems described in **chapter 5**.

This section contains information in the form of standard building widths, frame clearance dimensions, design live load, design wind speed, column reactions, and anchor bolt setting plans, that is useful to specifiers. Although this section pertains specifically to the standard buildings shown, this information may also serve as a guide to non-standard conditions.

Zamil Steel can, and often does, supply non-standard, “custom” buildings without additional charges for engineering. Non-standard buildings differ from standard structural systems in that they can have non-standard design loads, building widths, bay lengths, roof slopes, eave heights, module sizes etc.

For these special conditions, it is advisable that you seek the advice of a Zamil Steel representative or a Zamil Steel certified builder for the most economical framing system for your building prior to specifying the basic parameters of a building. Experience has demonstrated that consultation with a Zamil Steel representative prior to fixing the parameters of a building often results in overall building supply savings that range from 5% to 20%.

## Design Loads

Zamil Steel standard design loads are:

- Live load (LL) = 0.57 kN/m<sup>2</sup>
- Wind speed (WL) = 130 km/h

It is the responsibility of the buyer to provide Zamil Steel with the wind speed applicable to a particular project as wind speed varies drastically from area to area. Zamil Steel will not design a building for a wind speed that is lower than 110 km/h.

## Bay Length

A bay length of 7.5 m is used in this chapter because it is the most economical in most PEB applications. However, 9 m bay lengths are gaining popularity and acceptance because longer bays often result in savings to the overall project cost as their use results in lower foundation costs (fewer rigid frames translates into fewer footings). When bay lengths greater than 9 m are required, jack beams or open web joists are used. These permit bay lengths of up to 18 m.

## Eave Height

The eave heights noted in this chapter are the most common. Eave heights as high as 30 m can be accommodated. Consult your Zamil Steel representative for advice.

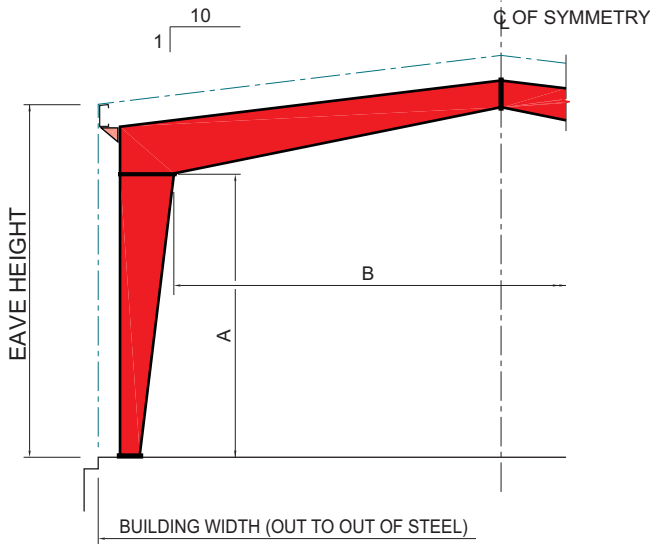

**CROSS SECTION**

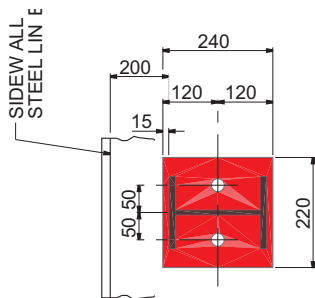

**COLUMN BASE PLAN**

**NOTES :**

1. THE POSITIVE DIRECTION OF LOADS AND REACTIONS IS INDICATED BY THE DIRECTION OF THE ARROWS.
2. ALL DATA ON THIS PAGE IS DERIVED FROM THE FOLLOWING :
  - DEAD LOAD (DL) = 0.10 kN/m<sup>2</sup>
  - LIVE LOAD (LL) = 0.57 kN/m<sup>2</sup>
  - WIND SPEED = 130 km/h
  - BAY LENGTH = 7.5 m
3. "WL" IS THE WIND LOAD RESULTING FROM THE SPECIFIED WIND SPEED. WIND LOAD IS APPLIED IN ACCORDANCE WITH MBMA 1996 MANUAL.
4. TO CALCULATE COLUMN REACTIONS FOR OTHER BAY LENGTHS, APPLY THE FOLLOWING MULTIPLIER FACTOR :
  - 6 m BAY = 0.80
  - 9 m BAY = 1.25
 NOTE : FOR BAY LENGTHS GREATER THAN 9 m, CONSULT A ZAMIL STEEL REPRESENTATIVE.
5. V = VERTICAL REACTIONS      H = HORIZONTAL REACTIONS  
 L = LEFT COLUMN                      R = RIGHT COLUMN
6. CLEARANCES SHOWN BELOW MAY VARY SLIGHTLY FOR 6 m AND 9 m BAYS.

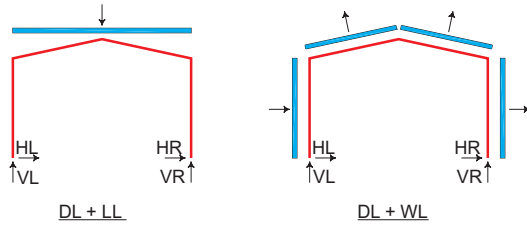

**COLUMN REACTIONS DIAGRAM**

BUILDING WIDTH (mm)	EAVE HEIGHT (mm)	MINIMUM CLEARANCE (mm)	
		A	B
12000	4000	3470	10940
	6000	5470	10940
	8000	7340	10540
15000	4000	3380	13740
	6000	5380	13740
	8000	7340	13540
18000	4000	3250	16538
	6000	5250	16538
	8000	7250	16538
21000	4000	3200	19338
	6000	5200	19338
	8000	7200	19338
24000	4000	3160	22138
	6000	5160	22138
	8000	7160	22138

COLUMN REACTIONS (kN)					
DL + LL		DL + WL			
VL = VR	(+)HL = (-)HR	VL	HL	VR	HR
35	15	-20	-15	-15	-5
35	10	-25	-15	-10	-15
35	10	-35	-20	-10	-20
40	25	-25	-20	-15	5
45	15	-30	-20	-15	-5
45	10	-35	-20	-15	-15
50	35	-30	-25	-20	10
50	25	-35	-25	-20	-5
50	15	-40	-25	-20	-10
60	55	-30	-30	-25	20
60	30	-40	-25	-25	5
60	25	-45	-30	-25	-10
70	70	-35	-40	-25	30
70	50	-45	-35	-30	15
70	35	-50	-35	-30	-5



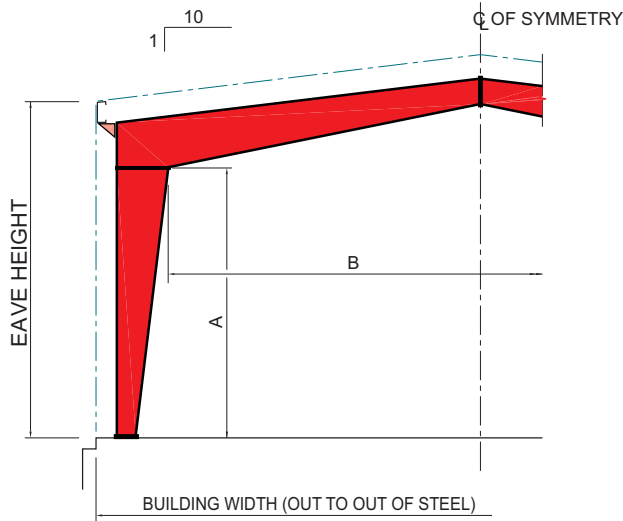

**CROSS SECTION**

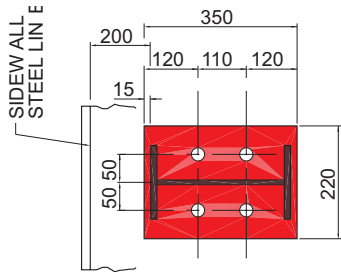

FOR 30 & 36 METER BUILDING WIDTHS  
**COLUMN BASE PLAN**

**NOTES :**

1. THE POSITIVE DIRECTION OF LOADS AND REACTIONS IS INDICATED BY THE DIRECTION OF THE ARROWS.
2. ALL DATA ON THIS PAGE IS DERIVED FROM THE FOLLOWING :
  - DEAD LOAD (DL) = 0.10 kN/m<sup>2</sup>
  - LIVE LOAD (LL) = 0.57 kN/m<sup>2</sup>
  - WIND SPEED = 130 km/h
  - BAY LENGTH = 7.5 m
3. "WL" IS THE WIND LOAD RESULTING FROM THE SPECIFIED WIND SPEED. WIND LOAD IS APPLIED IN ACCORDANCE WITH MBMA 1996 MANUAL.
4. TO CALCULATE COLUMN REACTIONS FOR OTHER BAY LENGTHS, APPLY THE FOLLOWING MULTIPLIER FACTOR :
  - 6 m BAY = 0.80
  - 9 m BAY = 1.25
 NOTE : FOR BAY LENGTHS GREATER THAN 9 m, CONSULT A ZAMIL STEEL REPRESENTATIVE.
5. V = VERTICAL REACTIONS      H = HORIZONTAL REACTIONS  
L = LEFT COLUMN                      R = RIGHT COLUMN
6. CLEARANCES SHOWN BELOW MAY VARY SLIGHTLY FOR 6 m AND 9 m BAYS.

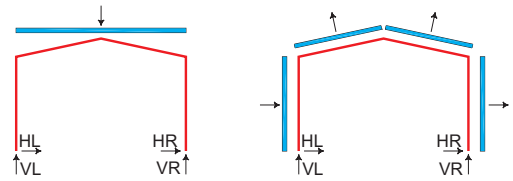

**COLUMN REACTIONS DIAGRAM**

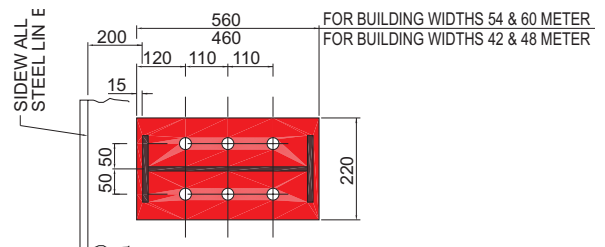

FOR 42 , 48 , 54 , & 60 METER BUILDING WIDTHS  
**COLUMN BASE PLAN**

BUILDING WIDTH (mm)	EAVE HEIGHT (mm)	MINIMUM CLEARANCE (mm)	
		A	B
30000	4000	3060	27934
	6000	5060	27734
	8000	7060	27734
36000	6000	4880	33530
	8000	6880	33530
42000	6000	4880	39134
	8000	6880	39134
48000	6000	4700	44930
	8000	6700	44930
54000	6000	4700	51126
	8000	6700	50726
60000	6000	4690	56530
	8000	6690	56526

COLUMN REACTIONS (kN)					
DL + LL		DL + WL			
VL = VR	(+)HL = (-)HR	VL	HL	VR	HR
85	110	-45	-55	-30	45
85	75	-50	-50	-35	30
85	60	-55	-45	-35	15
105	115	-60	-65	-40	-45
105	90	-65	-60	-45	-35
125	155	-65	-80	-45	-65
125	120	-70	-75	-50	-50
145	200	-70	-100	-50	80
145	155	-80	-90	-55	65
165	250	-80	-115	-55	100
165	195	-85	-105	-60	80
185	310	-80	-130	-55	115
190	245	-90	-120	-60	95

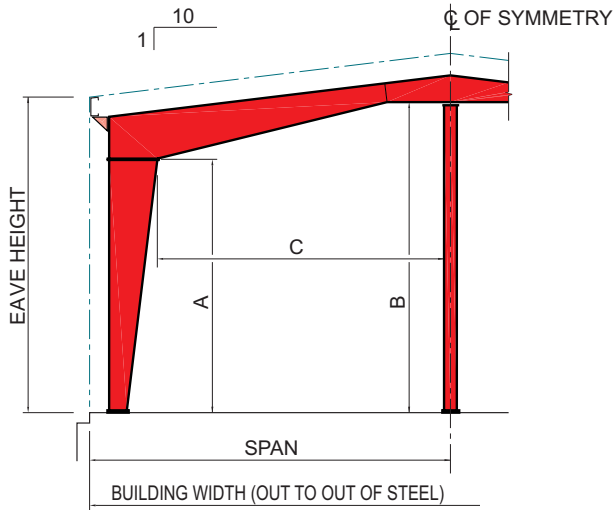

**CROSS SECTION**

**NOTES :**

1. THE POSITIVE DIRECTION OF LOADS AND REACTIONS IS INDICATED BY THE DIRECTION OF THE ARROWS.
2. ALL DATA ON THIS PAGE IS DERIVED FROM THE FOLLOWING :
  - DEAD LOAD (DL) = 0.10 kN/m<sup>2</sup>
  - LIVE LOAD (LL) = 0.57 kN/m<sup>2</sup>
  - WIND SPEED = 130 km/h
  - BAY LENGTH = 7.5 m
3. "WL" IS THE WIND LOAD RESULTING FROM THE SPECIFIED WIND SPEED. WIND LOAD IS APPLIED IN ACCORDANCE WITH MBMA 1996 MANUAL.
4. TO CALCULATE COLUMN REACTIONS FOR OTHER BAY LENGTHS, APPLY THE FOLLOWING MULTIPLIER FACTOR :
  - 6 m BAY = 0.80
  - 9 m BAY = 1.25
 NOTE : FOR BAY LENGTHS GREATER THAN 9 m, CONSULT A ZAMIL STEEL REPRESENTATIVE.
5. V = VERTICAL REACTIONS      H = HORIZONTAL REACTIONS  
L = LEFT COLUMN                      R = RIGHT COLUMN
6. CLEARANCES SHOWN BELOW MAY VARY SLIGHTLY FOR 6 m AND 9 m BAYS.

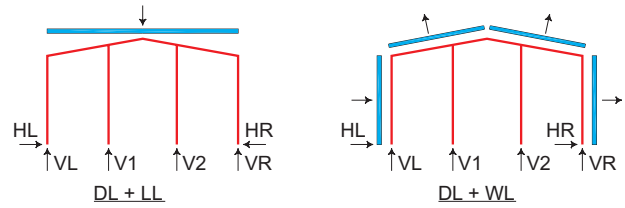

**COLUMN REACTIONS DIAGRAM**

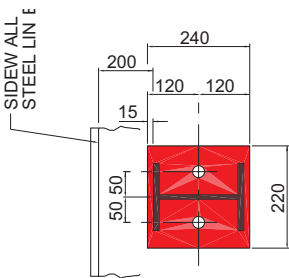

FOR 24 & 30 METER BUILDING WIDTHS.

**COLUMN BASE PLAN**

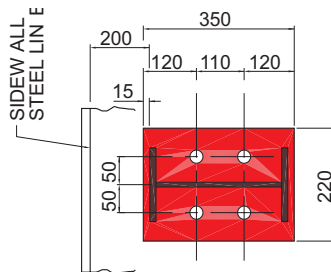

FOR 36, 42 & 48 METER BUILDING WIDTH.

**COLUMN BASE PLAN**

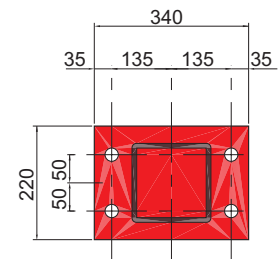

**INTERIOR COLUMN BASE PLAN**

BUILDING WIDTH (mm)	EAVE HEIGHT (mm)	MINIMUM CLEARANCE (mm)		
		A	B	C
24000	4000	3520	4384	11370
	6000	5520	6384	11370
	8000	7340	8384	11170
30000	4000	3430	4682	14370
	6000	5430	6682	14370
	8000	7340	8684	14170
36000	6000	5340	6881	17170
	8000	7340	8881	17170
42000	6000	5340	7079	20169
	8000	7340	9079	20170
48000	6000	5250	7375	22969
	8000	7250	9375	22969

COLUMN REACTIONS (kN)							
DL + LL				DL + WL			
VL = VR	HL = HR	V1	VL	HL	V1	VR	HR
30	10	80	-20	-10	-40	-10	-5
30	5	80	-25	-15	-45	-10	-10
30	5	80	-30	-20	-45	-10	20
35	15	95	-25	-15	-45	-15	5
35	10	100	-30	-15	-55	-15	-10
40	10	100	-35	-20	-55	-15	-15
45	20	110	-35	-20	-60	-20	-5
45	10	110	-40	-20	-70	-15	-15
55	25	130	-40	-20	-70	-20	55
5	15	140	-45	-25	-80	-20	-10
65	45	140	-45	-30	-70	-25	15
65	30	145	-50	-30	-80	-25	-5

# CHAPTER 4 : STANDARD STRUCTURAL SYSTEMS

## Section 4.3 : Multi-Span II Buildings (Two Interior Columns) 2 of 3

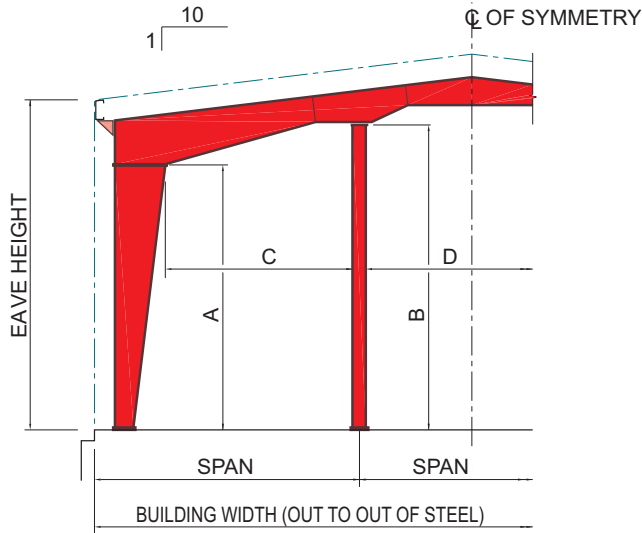

CROSS SECTION

NOTES :

1. THE POSITIVE DIRECTION OF LOADS AND REACTIONS IS INDICATED BY THE DIRECTION OF THE ARROWS.
2. ALL DATA ON THIS PAGE IS DERIVED FROM THE FOLLOWING :
  - DEAD LOAD (DL) = 0.10 kN/m<sup>2</sup>
  - LIVE LOAD (LL) = 0.57 kN/m<sup>2</sup>
  - WIND SPEED = 130 km/h
  - BAY LENGTH = 7.5 m
3. "WL" IS THE WIND LOAD RESULTING FROM THE SPECIFIED WIND SPEED. WIND LOAD IS APPLIED IN ACCORDANCE WITH MBMA 1996 MANUAL.
4. TO CALCULATE COLUMN REACTIONS FOR OTHER BAY LENGTHS, APPLY THE FOLLOWING MULTIPLIER FACTOR :
  - 6 m BAY = 0.80
  - 9 m BAY = 1.25
 NOTE : FOR BAY LENGTHS GREATER THAN 9 m, CONSULT A ZAMIL STEEL REPRESENTATIVE.
5. V = VERTICAL REACTIONS      H = HORIZONTAL REACTIONS  
L = LEFT COLUMN                      R = RIGHT COLUMN
6. CLEARANCES SHOWN BELOW MAY VARY SLIGHTLY FOR 6 m AND 9 m BAYS.

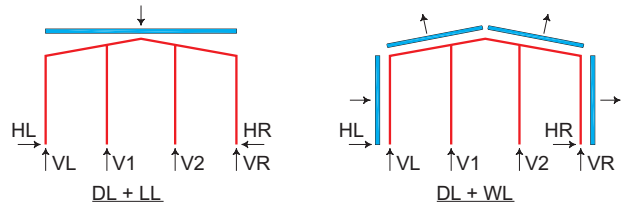

COLUMN REACTIONS DIAGRAM

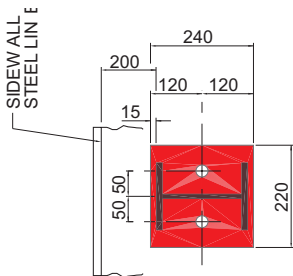

FOR 36 & 45 METER BUILDING WIDTHS

COLUMN BASE PLAN

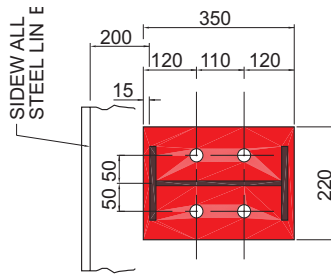

FOR 54, 63 & 72 METER BUILDING WIDTH

COLUMN BASE PLAN

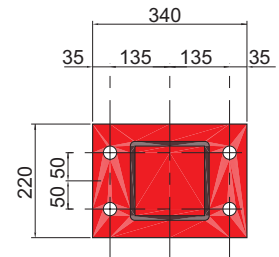

INTERIOR COLUMN BASE PLAN

BUILDING WIDTH (mm)	EAVE HEIGHT (mm)	MINIMUM CLEARANCE (mm)			
		A	B	C	D
36000	4000	3520	4633	11370	11800
	6000	5520	6633	11370	11800
	8000	7340	8633	11170	11800
45000	4000	3340	4782	14170	14800
	6000	5340	6782	14170	14800
	8000	7340	8782	14170	14800
54000	6000	5250	6980	17169	17800
	8000	7250	8980	17169	17800
63000	6000	5250	7276	20069	20800
	8000	7250	9276	20069	20800
72000	6000	5070	7572	23069	23800
	8000	7070	9572	23069	23800

COLUMN REACTIONS (kN)								
DL + LL			DL + WL					
VL=VR	HL=HR	V1=V2	VL	HL	V1	V2	VR	HR
35	15	70	-20	-15	-45	-25	-15	-5
30	10	70	-25	-15	-45	-35	-15	-10
35	10	70	-30	-20	-45	-40	-10	-15
45	30	80	-30	-20	-55	-30	-20	10
40	20	85	-30	-20	-60	-35	-20	-5
40	15	85	-35	-20	-60	-45	-15	-15
50	20	100	-35	-20	-70	-40	-20	-5
50	15	105	-40	-25	-75	-50	-20	-10
60	35	115	-40	-25	-85	-45	-25	10
60	25	120	-45	-30	-90	-50	-25	-5
70	40	135	-45	-30	-95	-50	-30	15
70	25	140	-50	-30	-105	-60	-30	-5

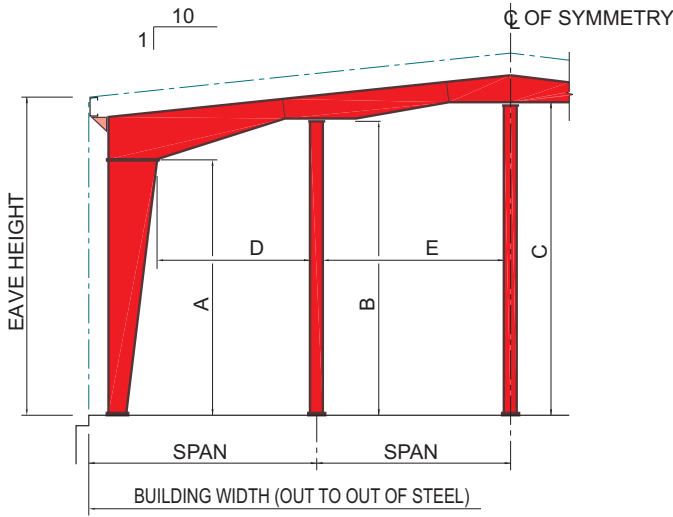

**CROSS SECTION**

**NOTES :**

1. THE POSITIVE DIRECTION OF LOADS AND REACTIONS IS INDICATED BY THE DIRECTION OF THE ARROWS.
2. ALL DATA ON THIS PAGE IS DERIVED FROM THE FOLLOWING :
  - DEAD LOAD (DL) = 0.10 kN/m<sup>2</sup>
  - LIVE LOAD (LL) = 0.57 kN/m<sup>2</sup>
  - WIND SPEED = 130 km/h
  - BAY LENGTH = 7.5 m
3. "WL" IS THE WIND LOAD RESULTING FROM THE SPECIFIED WIND SPEED. WIND LOAD IS APPLIED IN ACCORDANCE WITH MBMA 1996 MANUAL.
4. TO CALCULATE COLUMN REACTIONS FOR OTHER BAY LENGTHS, APPLY THE FOLLOWING MULTIPLIER FACTOR :
  - 6 m BAY = 0.80
  - 9 m BAY = 1.25
 NOTE : FOR BAY LENGTHS GREATER THAN 9 m, CONSULT A ZAMIL STEEL REPRESENTATIVE.
5. V = VERTICAL REACTIONS  
L = LEFT COLUMN  
R = RIGHT COLUMN
6. CLEARANCES SHOWN BELOW MAY VARY SLIGHTLY FOR 6 m AND 9 m BAYS.

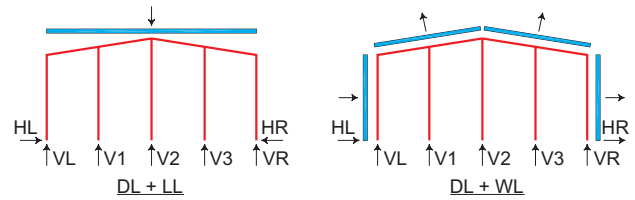

**COLUMN REACTIONS DIAGRAM**

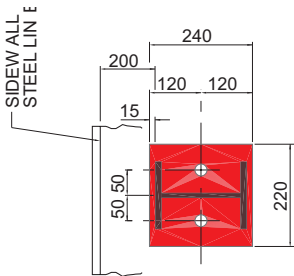

FOR 48 & 60 METER BUILDING WIDTHS

**COLUMN BASE PLAN**

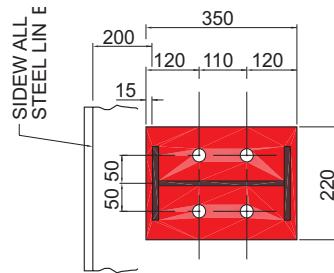

FOR 72, 84 & 96 METER BUILDING WIDTHS

**COLUMN BASE PLAN**

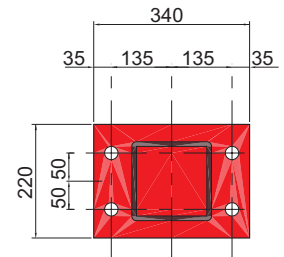

**INTERIOR COLUMN BASE PLAN**

BLDG. WIDTH (mm)	EAWE HEIGHT (mm)	MINIMUM CLEARANCE (mm)				
		A	B	C	D	E
48000	4000	3520	4484	5584	11370	11800
	6000	5520	6484	7584	11370	11800
	8000	7340	8683	9584	11170	11800
60000	4000	3430	4684	6184	14270	14800
	6000	5430	6684	8184	14270	14800
	8000	7340	8682	10184	14270	14800
72000	6000	5340	6879	8784	17170	17800
	8000	7340	8879	10784	17170	17800
84000	6000	5250	7175	9283	20169	20800
	8000	7250	9175	11283	20169	20800
96000	6000	5160	7375	10185	22969	23800
	8000	7160	9373	12185	23069	23800

COLUMN REACTIONS (kN)										
DL + LL				DL + WL						
VL=VR	HL=HR	V1=V3	V2	VL	HL	V1	V2	V3	VR	HR
30	10	75	60	-20	-10	-50	-30	-25	-15	-5
30	10	75	60	-25	-15	-55	-35	-30	-10	-10
35	10	65	70	-30	-20	-50	-45	-35	-15	-15
40	20	90	70	-25	-15	-60	-35	-30	-15	5
40	15	95	75	-25	-15	-70	-40	-40	-15	-5
40	10	95	75	-30	-20	-75	-45	-45	-15	-15
45	20	115	85	-30	-20	-85	-45	-45	-20	-5
45	15	115	90	-35	-20	-90	-50	-55	-20	-10
55	25	130	105	-35	-20	-95	-55	-50	-25	5
55	15	130	105	-40	-20	-105	-60	-55	-25	-10
65	35	145	120	-40	-25	-110	-60	-50	-25	10
65	25	155	120	-45	-25	-120	-65	-60	-25	-5

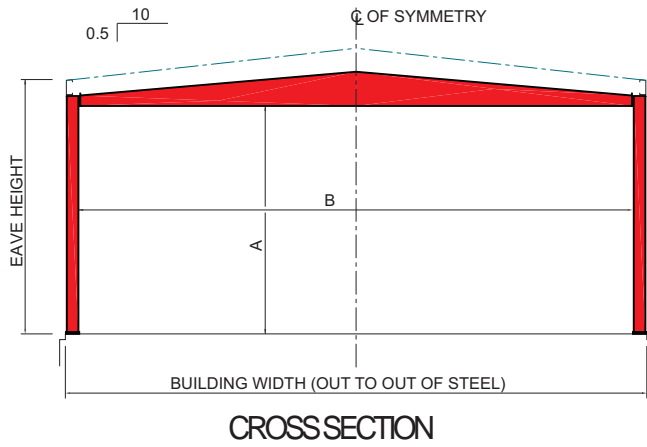

**NOTES :**

1. THE POSITIVE DIRECTION OF LOADS AND REACTIONS IS INDICATED BY THE DIRECTION OF THE ARROWS.
2. ALL DATA ON THIS PAGE IS DERIVED FROM THE FOLLOWING :
  - DEAD LOAD (DL) = 0.10 kN/m<sup>2</sup>
  - LIVE LOAD (LL) = 0.57 kN/m<sup>2</sup>
  - WIND SPEED = 130 km/h
  - BAY LENGTH = 7.5 m
3. "WL" IS THE WIND LOAD RESULTING FROM THE SPECIFIED WIND SPEED. WIND LOAD IS APPLIED IN ACCORDANCE WITH MBMA 1996 MANUAL.
4. TO CALCULATE COLUMN REACTIONS FOR OTHER BAY LENGTHS, APPLY THE FOLLOWING MULTIPLIER FACTOR :
  - 6 m BAY = 0.80
  - 9 m BAY = 1.25
 NOTE : FOR BAY LENGTHS GREATER THAN 9 m, CONSULT A ZAMIL STEEL REPRESENTATIVE.
5. V = VERTICAL REACTIONS      H = HORIZONTAL REACTIONS  
 L = LEFT COLUMN                  R = RIGHT COLUMN
6. CLEARANCES SHOWN BELOW MAY VARY SLIGHTLY FOR 6 m AND 9 m BAYS.

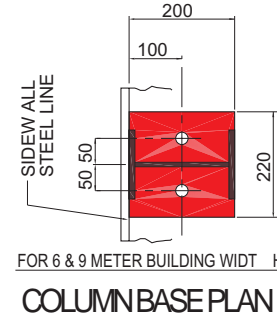
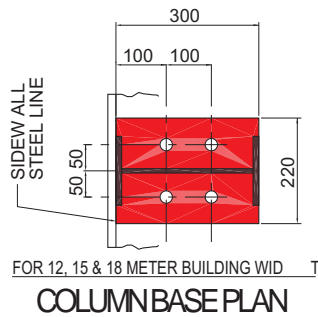
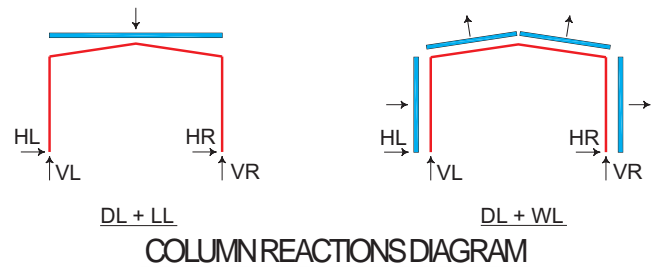

BUILDING WIDTH (mm)	EAVE HEIGHT (mm)	MINIMUM CLEARANCE (mm)	
		A	B
6000	4000	3590	5580
	6000	5590	5380
9000	4000	3590	8580
	6000	5590	8380
12000	4000	3590	11570
	6000	5580	11380
15000	4000	3490	14370
	6000	5490	14370
18000	4000	3480	17360
	6000	5480	17360

COLUMN REACTIONS (kN)					
DL + LL		DL + WL			
VL = VR	(+)HL = (-)HR	VL	HL	VR	HR
20	5	-15	-10	-5	-10
20	5	-25	-15	5	-15
25	5	-20	-10	-10	-10
30	5	-25	-12	-5	-15
35	15	-20	-15	-15	-5
35	10	-30	-15	-10	-10
50	15	-25	-15	-15	5
45	10	-30	-15	-15	-10
50	25	-30	-20	-20	5
50	15	-35	-20	-20	-10

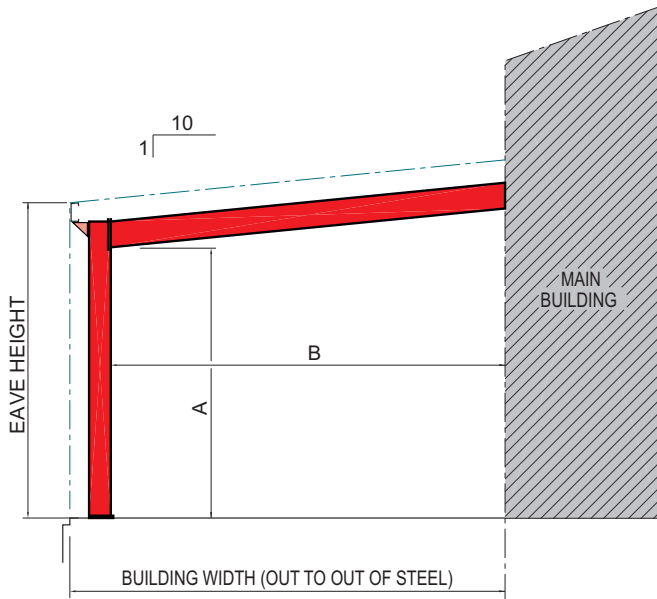

**CROSS SECTION**

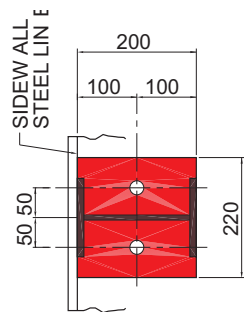

**COLUMN BASE PLAN**

**NOTES :**

1. THE POSITIVE DIRECTION OF LOADS AND REACTIONS IS INDICATED BY THE DIRECTION OF THE ARROWS.
2. ALL DATA ON THIS PAGE IS DERIVED FROM THE FOLLOWING :
  - DEAD LOAD (DL) = 0.10 kN/m<sup>2</sup>
  - LIVE LOAD (LL) = 0.57 kN/m<sup>2</sup>
  - WIND SPEED = 130 km/h
  - BAY LENGTH = 7.5 m
3. "WL" IS THE WIND LOAD RESULTING FROM THE SPECIFIED WIND SPEED. WIND LOAD IS APPLIED IN ACCORDANCE WITH MBMA 1996 MANUAL.
4. TO CALCULATE COLUMN REACTIONS FOR OTHER BAY LENGTHS, APPLY THE FOLLOWING MULTIPLIER FACTOR :
  - 6 m BAY = 0.80
  - 9 m BAY = 1.25
 NOTE : FOR BAY LENGTHS GREATER THAN 9 m, CONSULT A ZAMIL STEEL REPRESENTATIVE.
5. V = VERTICAL REACTIONS    H = HORIZONTAL REACTIONS  
 L = LEFT COLUMN            R = RIGHT COLUMN  
 WLL = WIND LOAD FROM LEFT    WLR = WIND LOAD FROM RIGHT
6. CLEARANCES SHOWN BELOW MAY VARY SLIGHTLY FOR 6m AND 9m BAYS.

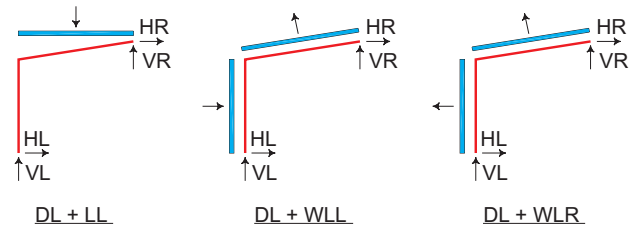

**COLUMN REACTIONS DIAGRAM**

BUILDING WIDTH (mm)	EAVE HEIGHT (mm)	MINIMUM CLEARANCE (mm)	
		A	B
6000	4000	3580	5590
	5000	4580	5590
	6000	5580	5590
9000	4000	3580	8590
	5000	4580	8590
	6000	5580	8590
12000	4000	3580	11590
	5000	4580	11590
	6000	5580	11590
15000	4000	3480	14590
	5000	4480	14590
	6000	5480	14590

COLUMN REACTIONS (kN)									
DL + LL		DL + WLL				DL + WLR			
VL=VR	HL=HR	VL	HL	VR	HR	VL	HL	VR	HR
20	0	-10	-4	-15	2	-6	6	-6	8
20	0	-15	-4	-15	2	-8	8	-6	10
20	0	-15	-4	-15	-2	-8	8	-8	10
25	0	-20	-4	-20	2	-10	6	-10	8
25	0	-20	-4	-20	2	-10	8	-10	10
25	0	-20	-4	-20	2	-15	8	-10	15
35	0	-25	-4	-25	4	-15	6	-15	10
35	0	-25	-4	-25	4	-15	8	-15	10
35	0	-25	-4	-25	4	-15	8	-15	15
45	0	-25	-4	-30	6	-15	6	-15	10
45	0	-30	-4	-30	6	-15	6	-15	15
45	0	-30	-4	-30	6	-20	8	-20	15

# **OTHER STRUCTURAL SYSTEMS**

# **C H A P T E R 5**

# 5. Other Structural Systems

5.1	General .....	81
5.2	Single Slope Buildings .....	82
5.3	Multi-Gable Buildings .....	84
5.4	Roof System Buildings .....	87
5.5	Flat Roof Buildings .....	90
5.6	Low Rise Buildings .....	93



The term “other” in this chapter is not to be understood to mean less important. The structural systems described in this chapter are viable and practical in many applications; But because they constitute less than 20% of end-user applications, it is not necessary to include a comprehensive set of standard details for them in this manual.

If your building requirements cannot be satisfied using the more economical standard structural systems that are presented in Chapter 4, be assured that Zamil Steel has the engineering capability and the experience to supply you with any of the following alternative building systems:

- Single Slope (SS) buildings
- Multi-Gable (MG) buildings
- Roof System (RS) buildings
- Flat Roof (FR) buildings
- Low Rise (LR) buildings

As the intention of this chapter is to make you aware of the existence of these alternative structural systems, only the basic concept of the above building systems is demonstrated here.

Like all our structural systems, the structural systems in this chapter can be customized to meet your unique requirements.



**Single Slope (SS)** buildings are economical in spans that are less than 12 meters. The most common conditions for using Single Slope buildings are:

- Whenever rain water drainage is required to be along one sidewall of the building only.
- When a new Single Slope building is added directly adjacent to an existing building and the designer is required to avoid:
  - the creation of a valley condition along the connection of both buildings that will result in an expensive water drainage system.
  - the imposition of additional loads on the columns of the existing building.
  - the imposition of additional loads on the foundations of the existing building.

For buildings wider than 12 m, it is common to specify a gable roof from economic, as well as aesthetic, considerations.

Single Slope buildings may be either Clear Spans or Multi-Spans.

A common application of Single Slope buildings are demountable buildings such as those used for site offices or camp accommodations. These are typically 3.6 m wide, 12 m long with a 2.4 m eave height at the lower side.



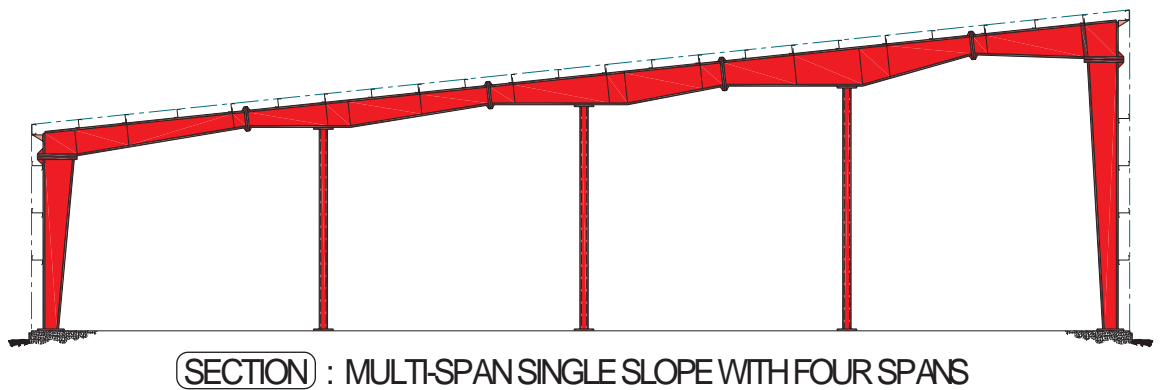
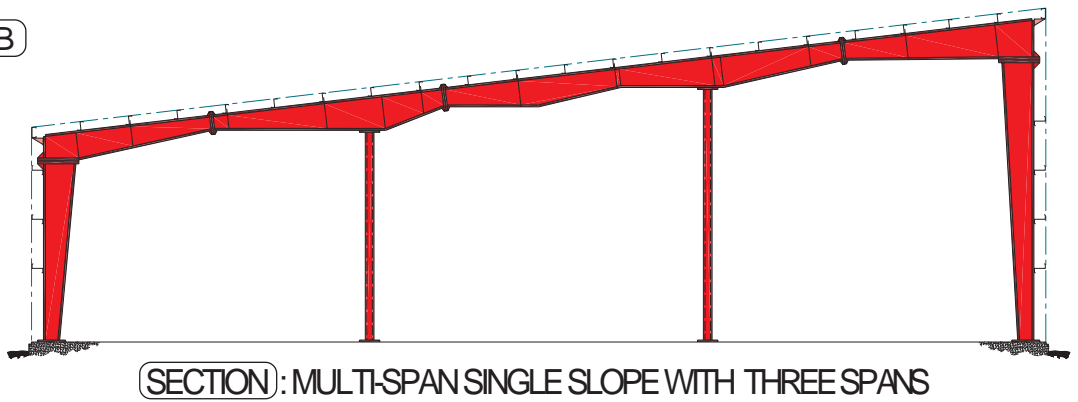
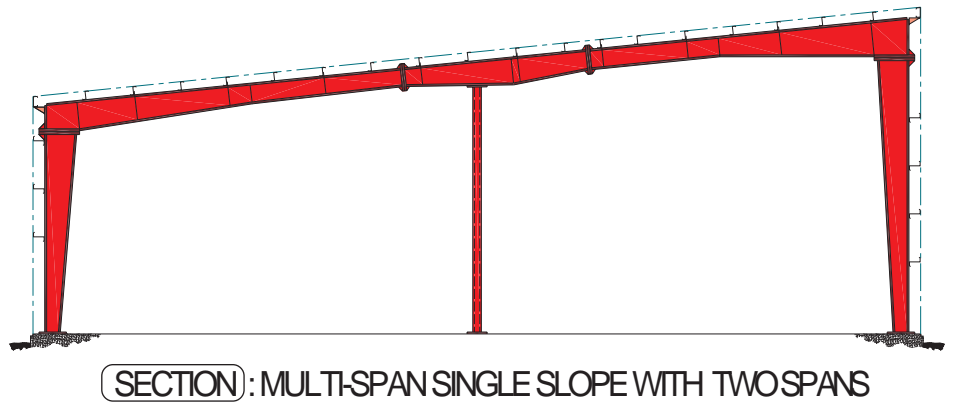
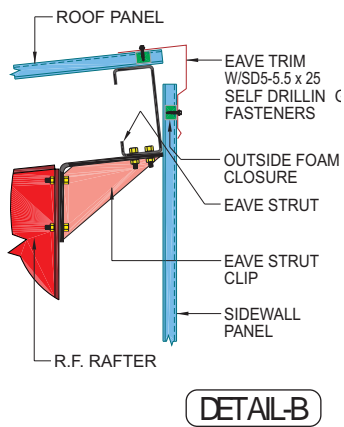
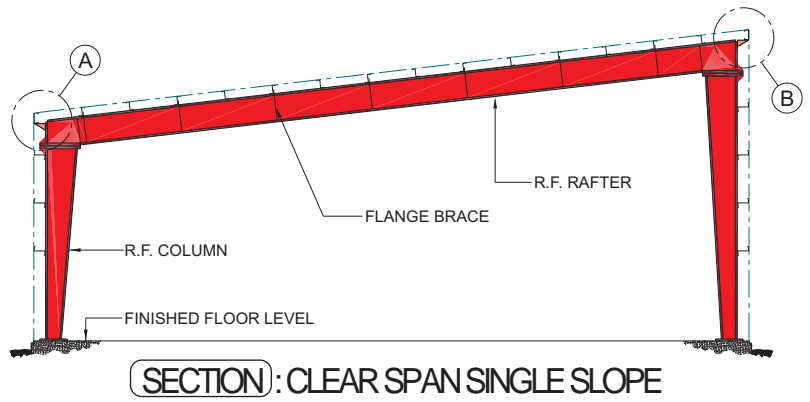
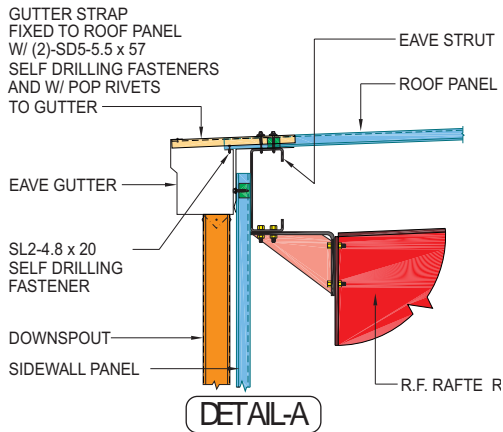

**Multi-Gable (MG)** buildings consist of two or more gable buildings sharing common sidewall columns.

Although Multi-Gable buildings are commonly used in many regions of the world, Zamil Steel recommends the use of Multi-Span buildings in lieu of Multi-Gable buildings because of the following practical reasons:

- The valley between gables requires frequent maintenance to prevent accumulation of residue such as sand, etc. that must be removed frequently.
- Access to valley gutters for cleaning is more cumbersome than accessing eave gutters. This access requires maintenance traffic on the roof, risking sheeting deterioration or damage.
- Risk of overflow of rainwater at valley during periods of extremely heavy rain (especially when the valley gutter between the buildings has not been maintained periodically).

- In long Multi-Gable buildings, interior downspouts have to be provided inside the buildings with horizontal drain pipes or concrete channels embedded in the concrete along the length of the buildings, under each valley gutter, to carry the water from the roof to an exterior location. The construction of such a water draining system is expensive and risky since blockage of these pipes can cause flooding inside the building.
- Wind bracing design for Multi-Gable buildings requires the provision of wind bracing members between the interior columns of the buildings. This bracing arrangement restricts interior movement and ease of access across the building.

However, Multi-Gable buildings have the advantage of reducing the height of the building ridge (peak) for very wide buildings.

Multi-Gable buildings may be either Clear Spans or Multi-Spans.



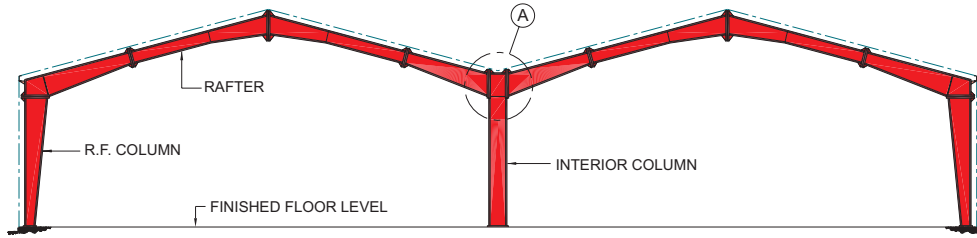

**CROSS SECTION** : MULTI-GABLE BUILDING WITH TWO CLEAR SPANS

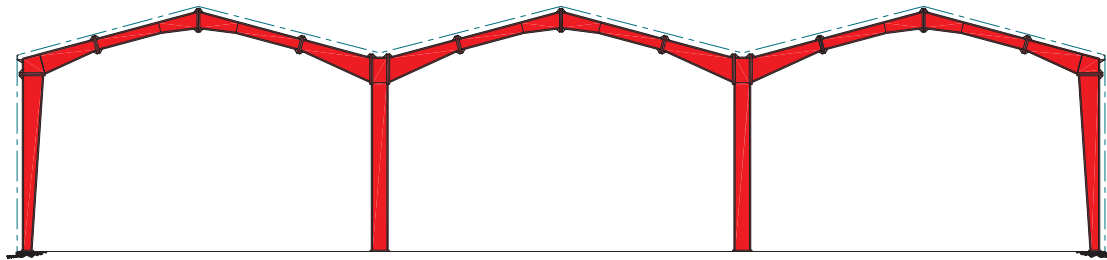

**CROSS SECTION** : MULTI-GABLE BUILDING WITH THREE CLEAR SPANS

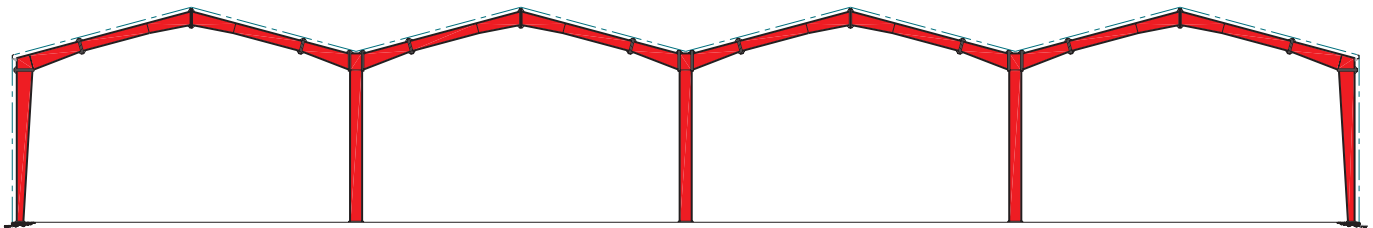

**CROSS SECTION** : MULTI-GABLE BUILDING WITH FOUR CLEAR SPANS

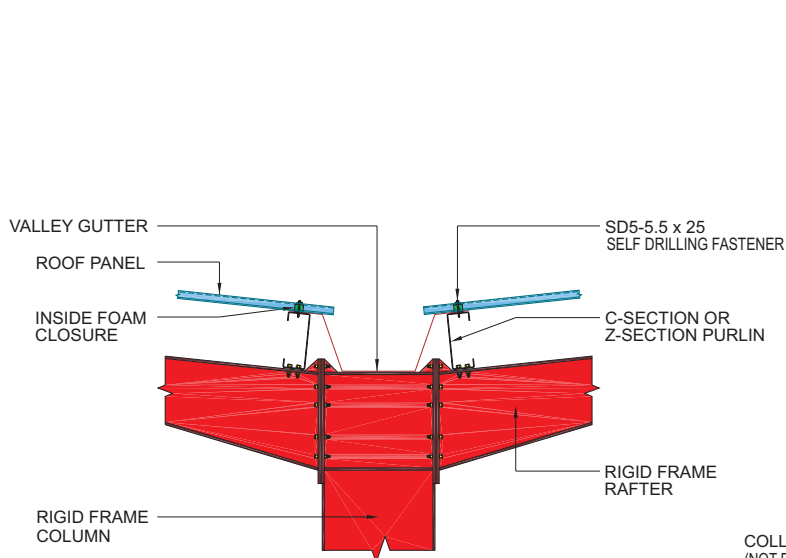

**DETAIL-A** : TYPICAL DETAIL AT VALLEY

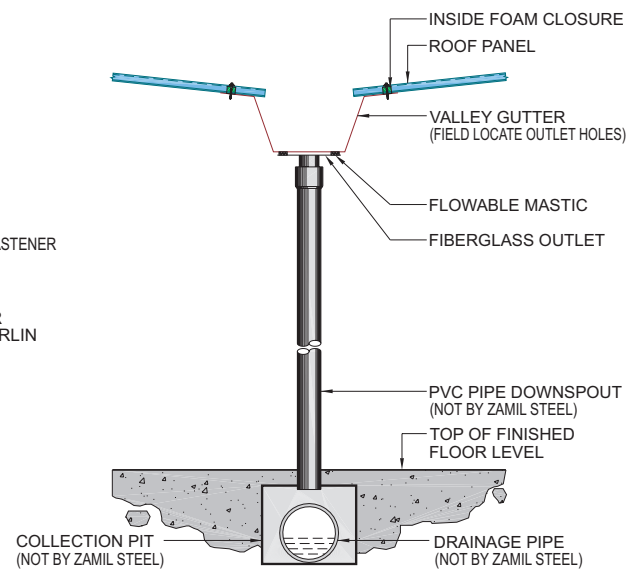

**DETAIL** : RECOMMENDED INTERIOR DRAINAGE ARRANGEMENT

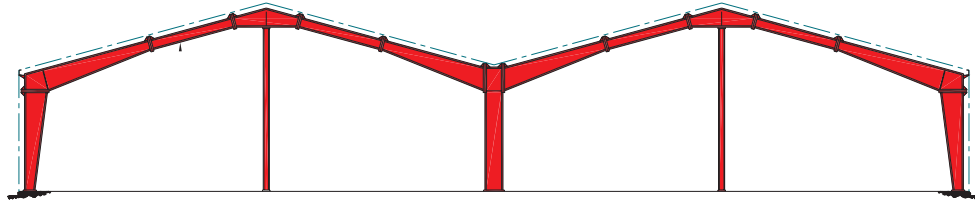

CROSS SECTION : MULTI-GABLE BLDG. WITH TWO GABLES EACH W/ TWO SPANS

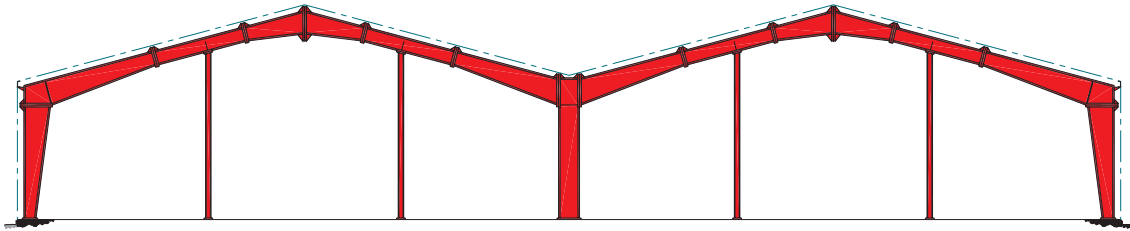

CROSS SECTION : MULTI-GABLE BLDG. WITH TWO GABLES EACH W/ THREE SPANS

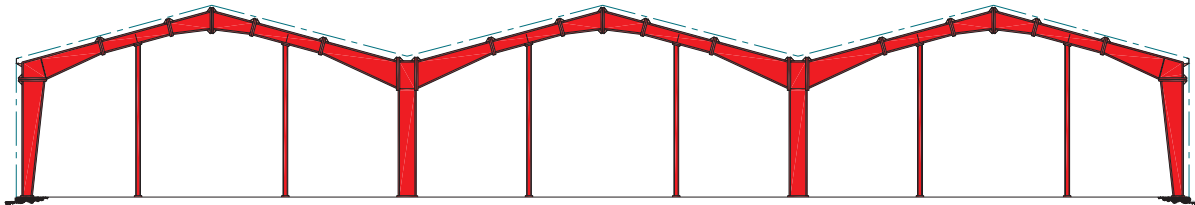

CROSS SECTION : MULTI-GABLE BLDG. WITH THREE GABLES EACH W/ THREE SPANS

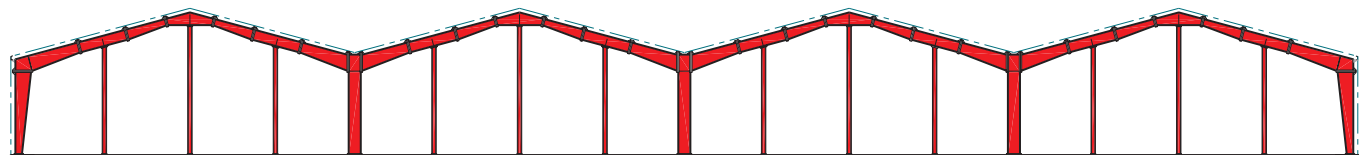

CROSS SECTION : MULTI-GABLE BLDG. WITH FOUR GABLES EACH W/ FOUR SPANS

A **Roof System** consists of roof rafters, purlins and sheeting specifically designed to install onto a planned or an existing substructure. The substructure is normally made of concrete or masonry.

When Zamil Steel supplies a Roof System it assumes that the supporting substructure was designed by a professional engineer and can withstand the load reactions resulting from the Zamil Steel Roof System. The customer's engineer must also ensure that his substructure is able to physically accommodate the required Zamil Steel anchor bolts and that the substructure is designed for the proper transfer of loads from the Roof System to the foundation.

Potential problems encountered in Roof Systems arise from not having square and accurate concrete dimensions (at rafter connection elevations) during the construction process. The tolerances required for proper anchor bolts setting ( $\pm 5$  mm) demand extreme care.

Close attention must be given to the interface between the concrete structure and the steel sheeting surface. Irregularities and height variations in the concrete may contribute to building leakage problems later.

A Roof System is generally not economical when compared to a complete pre-engineered building

especially for intermediate and large spans. This is due to the fact that the rigid frame action of a pre-engineered steel building distributes stresses optimally throughout the frame resulting in a lighter and more economical overall structure. In a Roof System, stresses are concentrated at the midspan of the roof rafter requiring heavier rafters.

Because of the application-specific requirements for this type of construction, it is difficult to create true "standards" for Roof Systems. The details on the following pages illustrate only the most common conditions typical to a Zamil Steel Roof System. "It is to be noted that wherever "building width" or "building length" is used, it refers to the structural system supplied by Zamil Steel and not to the substructure.



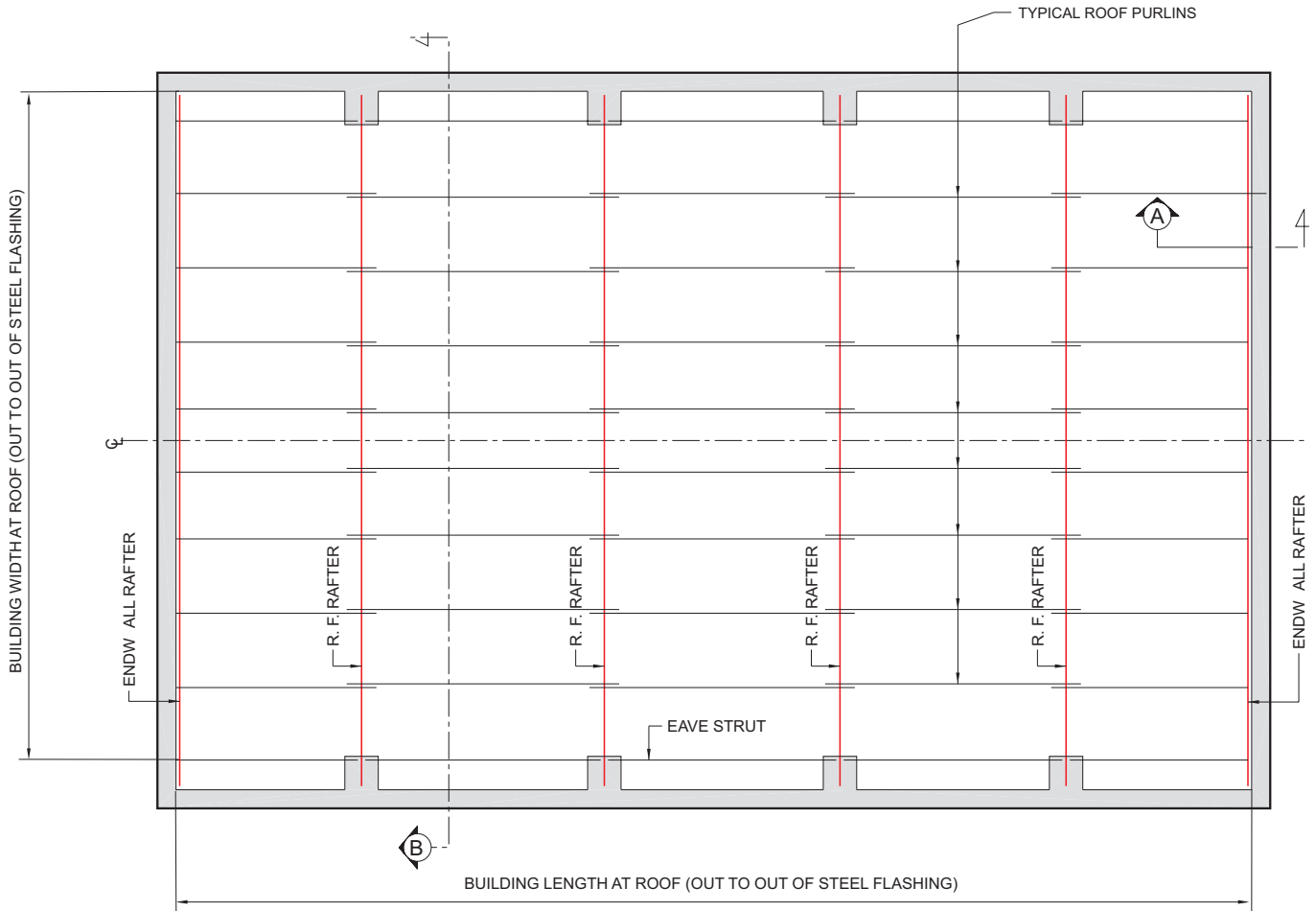

**PLAN** : ROOF FRAMING

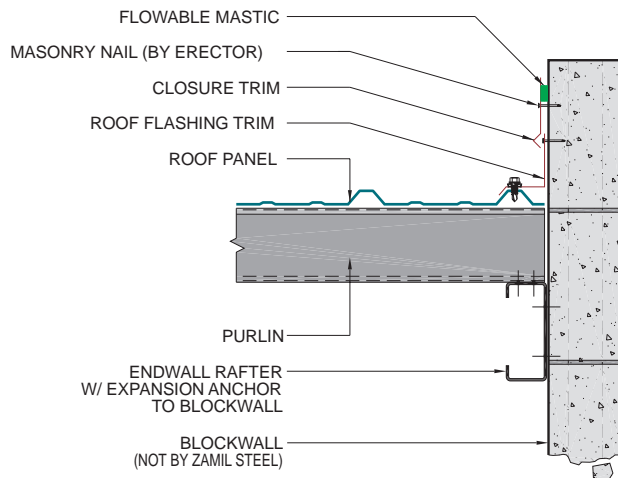

**SECTION A-A**



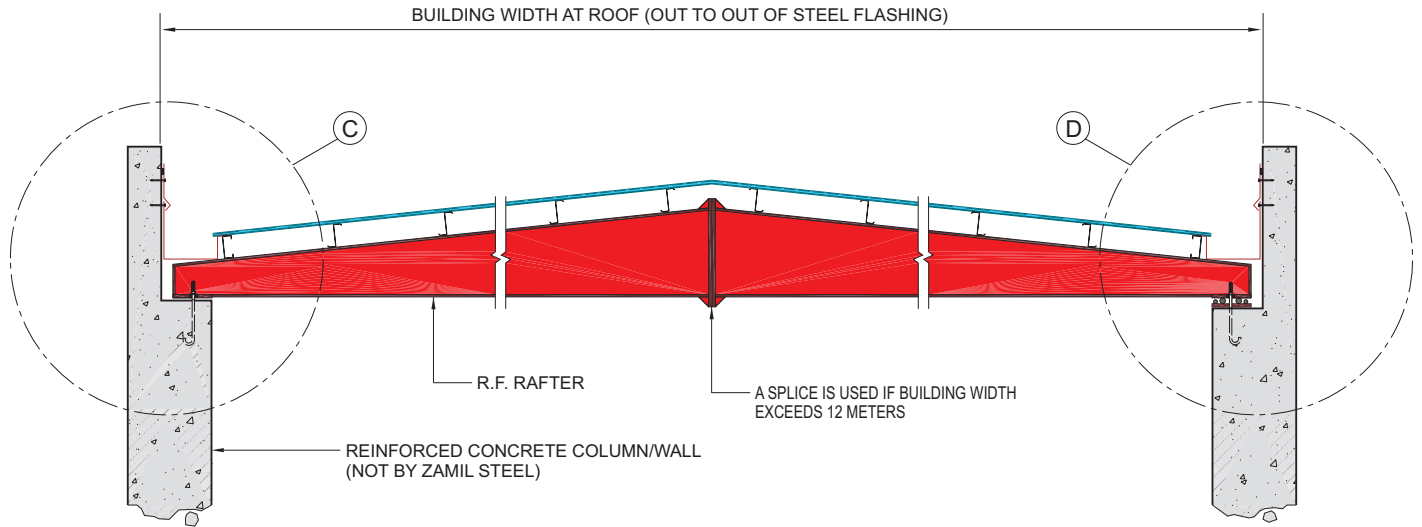

**SECTION-B** : ROOF SYSTEM FRAME CROSS SECTION

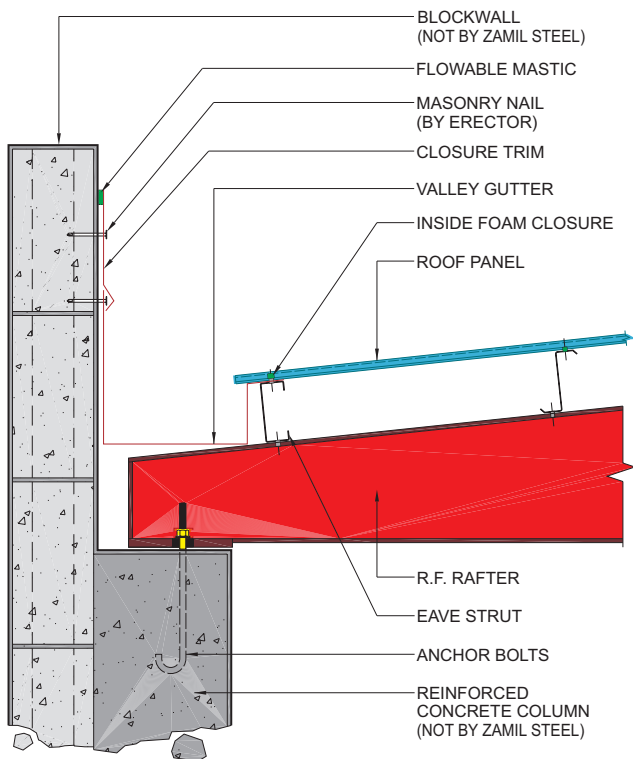

**DETAIL-C** : TYPICAL PINNED ARRANGEMENT

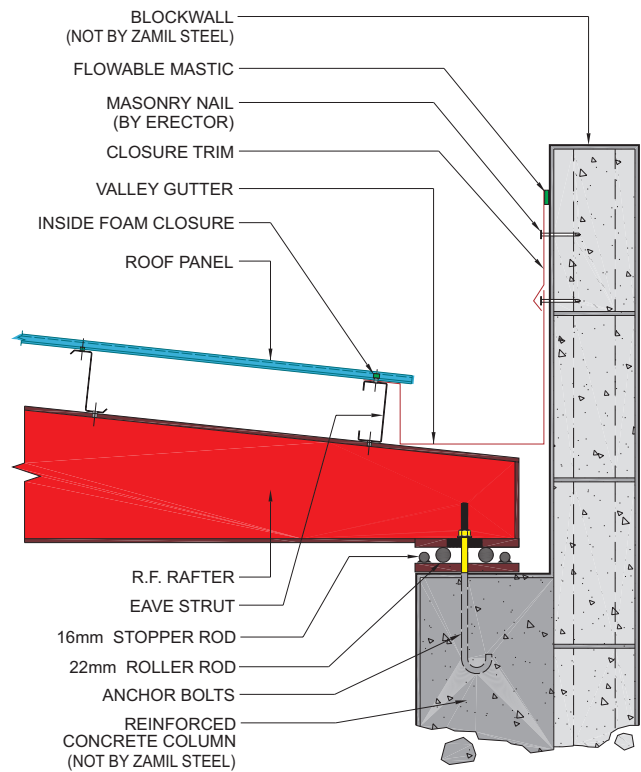

**DETAIL-D** : TYPICAL ROLLER ARRANGEMENT

A **Flat Roof** system provides the convenience of easy roof accessibility and is usually specified when the support of heavy unit loads, such as HVAC equipment, is a requirement.

Flat Roofs, particularly popular in low rise buildings, comprise of horizontal main frame rafters (beams) supporting joists (built-up or open web) and a structural steel deck. The steel deck commonly supports a finished floor made up of one of the following types of roof construction:

### Reinforced Concrete Slab

This is the traditional method of finishing flat roofs; it is identical to a mezzanine finished floor. The roof slab thickness (measured from the bottom of the steel deck to the top of finished concrete) is normally 100 mm thick. Water leakage is prevented by installing a waterproof membrane directly over the concrete slab and placing light weight fill material (sloped for drainage towards the centerline of the roof at 1/100) directly on top of the membrane. This is then tilted with plain concrete tiles whose joints are filled with sealant.

This form of construction has a dead weight that ranges from 3.0 to 4.5 kN/m<sup>2</sup> and a live load carrying capacity of approximately 5.0 kN/m<sup>2</sup>.

### Light-Weight Foam Concrete Slab

This finish approach uses slabs of light-weight foam concrete, cast on the steel deck, typically 100 mm thick at the perimeter of the roof and sloping (at 1/100) towards the centerline of the roof. A waterproofing membrane is installed directly over the foam concrete. Plain concrete tiles are then laid over the waterproofing membrane to provide the final finish surface. No sealant is required between the tiles.

This form of construction has a dead weight that ranges from 1.5 to 2.5 kN/m<sup>2</sup> and a live load carrying capacity between 1.0 and 2.5 kN/m<sup>2</sup>.

Care should be taken to determine whether heavy equipment is to be placed on the roof. Heavy equipment should be supported on elevated roof platforms and not directly on the foam concrete slab.

The details on the following pages apply to flat roofs that utilize a reinforced concrete slab.



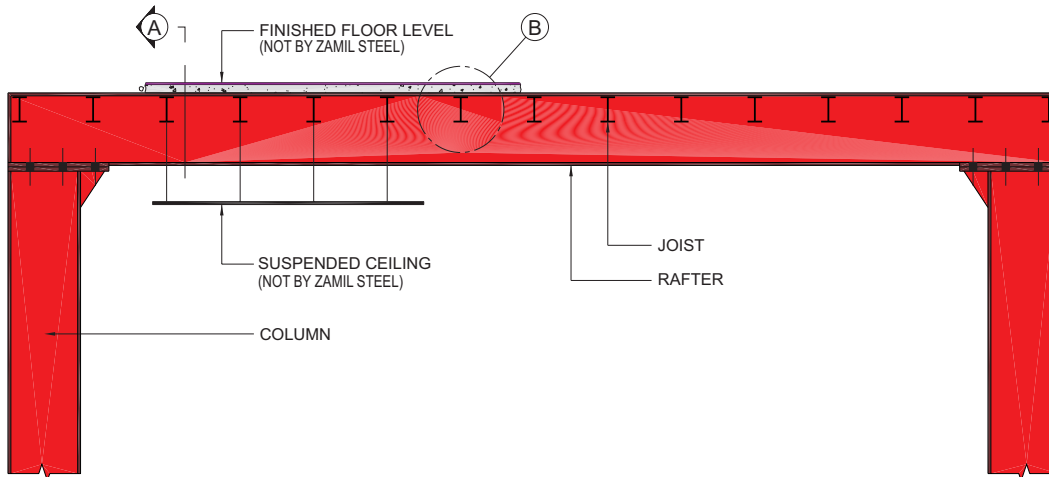

**SECTION:** TYPICAL FLAT ROOF CROSS SECTION

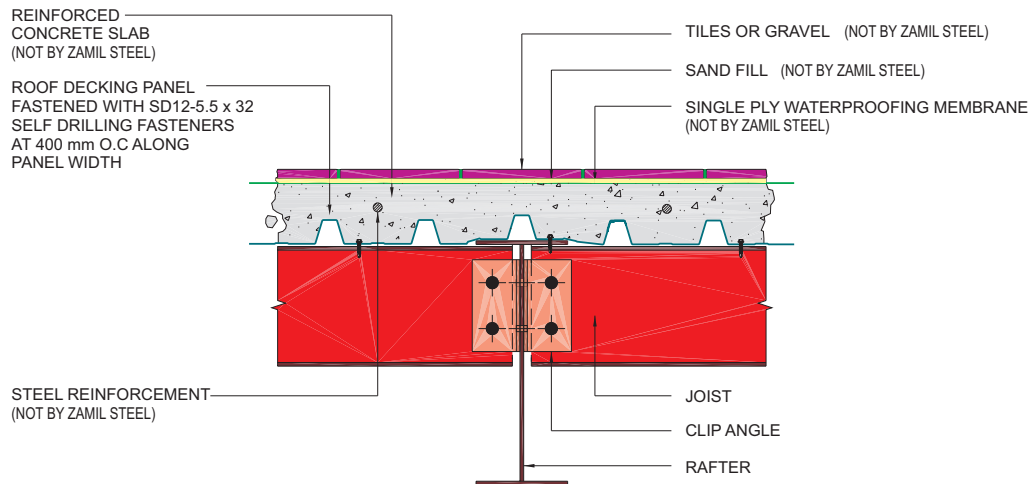

**SECTION-A:** JOIST CONNECTION

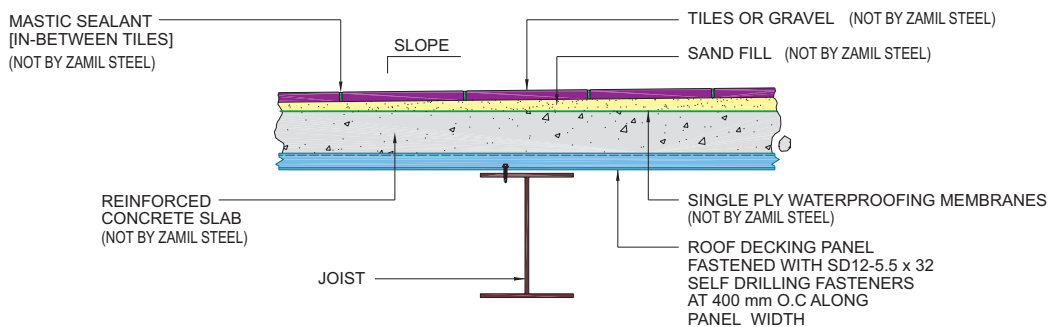

**DETAIL-B**

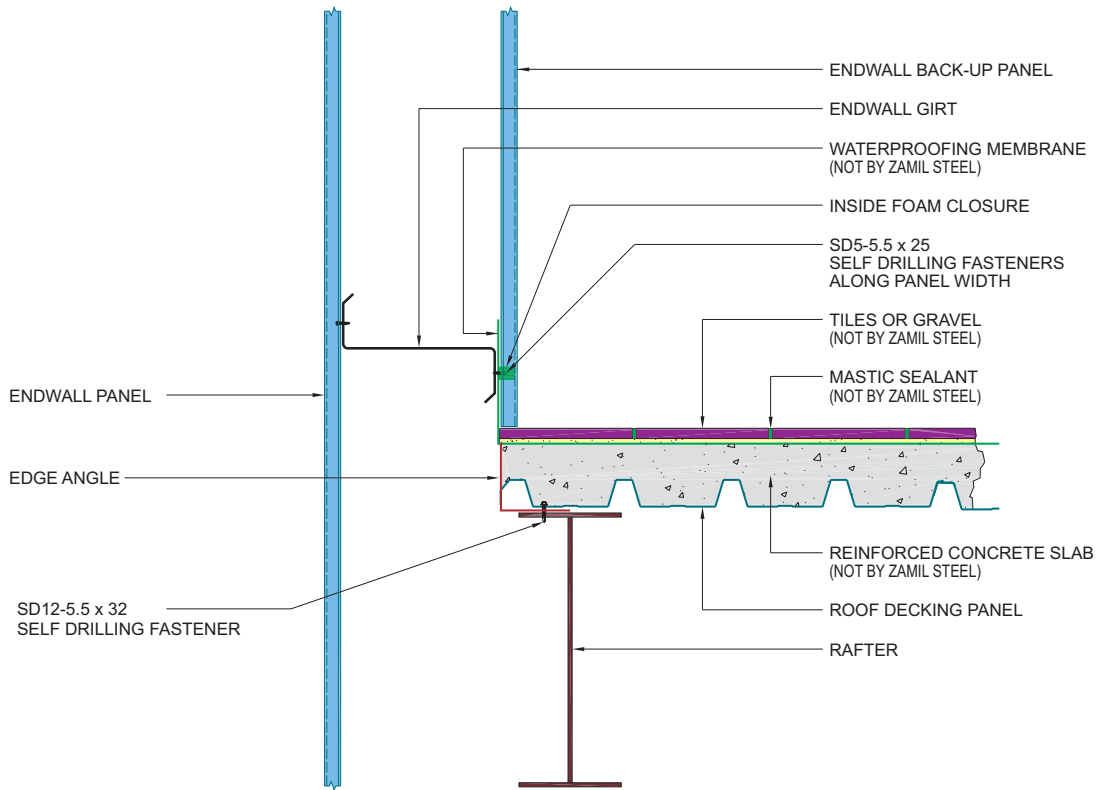

**DETAIL : ENDWALL PARAPET**

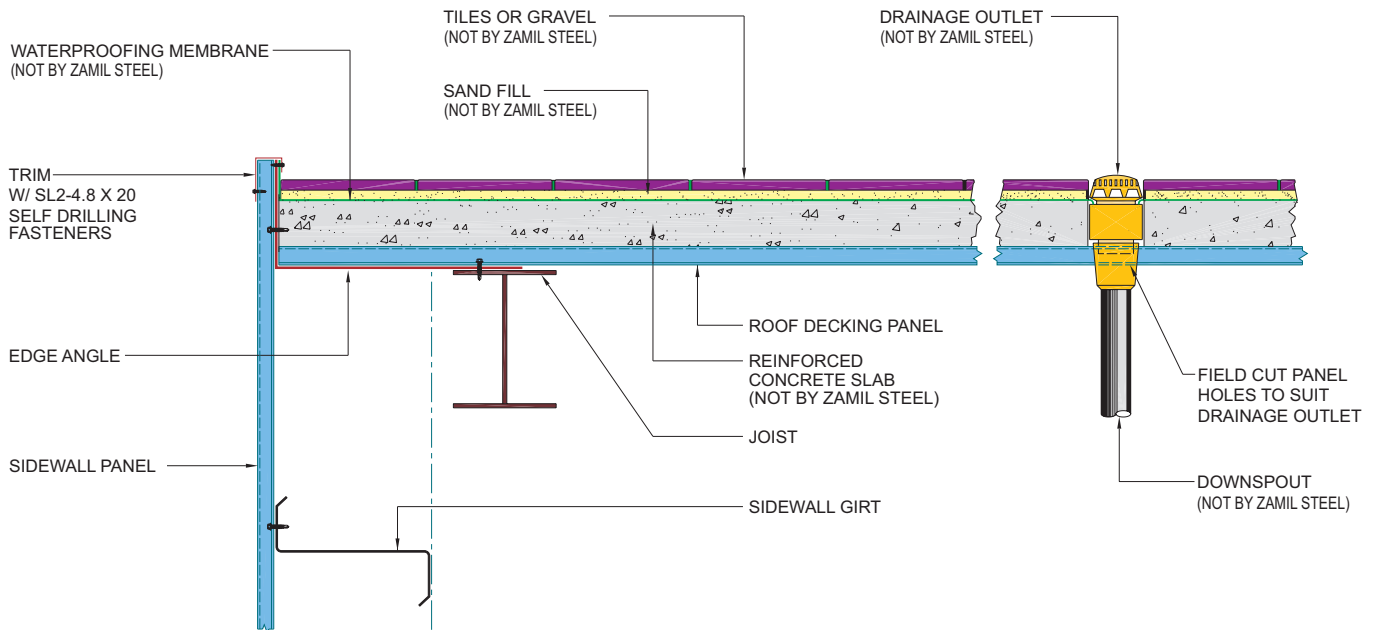

**DETAIL : SIDEWALL WITHOUT PARAPET**

**Low rise buildings** are ideal for offices and other commercial uses. Low rise buildings, utilizing the PEB approach, are not only more economical than traditional methods of construction but are often constructed in half the “normal” time especially when complemented with the following subsystems (not all included within Zamil Steel scope of supply) :

- Interior gypsum board liner
- Interior gypsum board partitions
- Central air conditioning ducting
- Suspended ceiling

In addition to speed of construction and the economy of supply, pre-engineered buildings can be neat and elegant in appearance when accessorised with parapet walls and accented with contrasting trim colors.

The most common (and most economical) example of a low rise steel building is a building with a **ground floor + two intermediate floors + roof**.

The roof of a low rise building may be *flat* or *sloped*. Details of flat roof construction can be found in **section 5.5**. Sloped roof details are found throughout this manual, particularly in **chapters 6 and 7**.

Intermediate floors of low rise buildings are made of mezzanine systems whose details are shown in **section 11.2**.

Zamil Steel low rise buildings may be supplied without exterior cladding to enable architects to interface their own special exterior designs utilizing blockwalls, marble, curtainwalls, etc.

Exterior and interior column spacing of Zamil Steel low rise buildings range from 6 m to 9 m, with 9 m being the most economical and practical. Built-up columns and rafters for low rise buildings are typically of constant depth to simplify interior clearance calculations.

Zamil Steel works closely with Consultants and Architects to preserve their general architectural requirements while incorporating their functional features within the overall Zamil Steel building design.



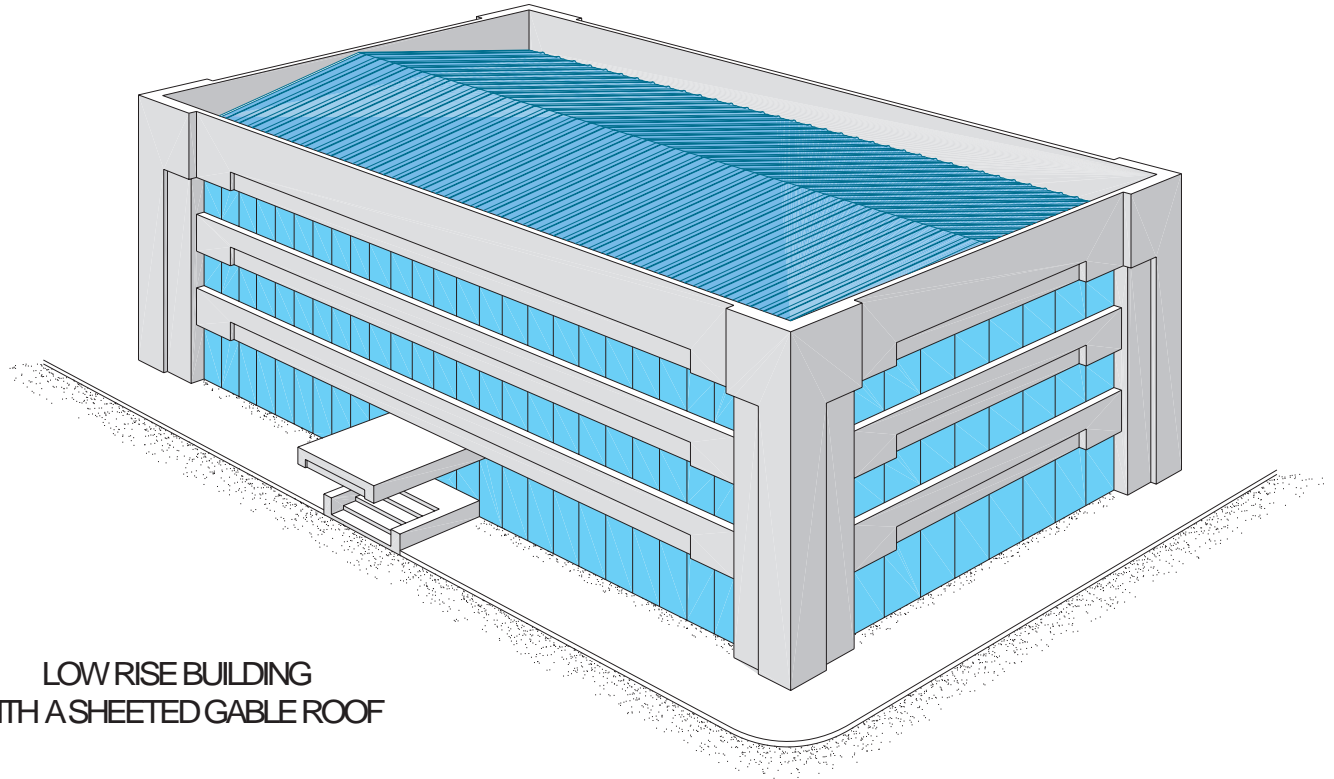

LOW RISE BUILDING  
WITH A SHEETED GABLE ROOF

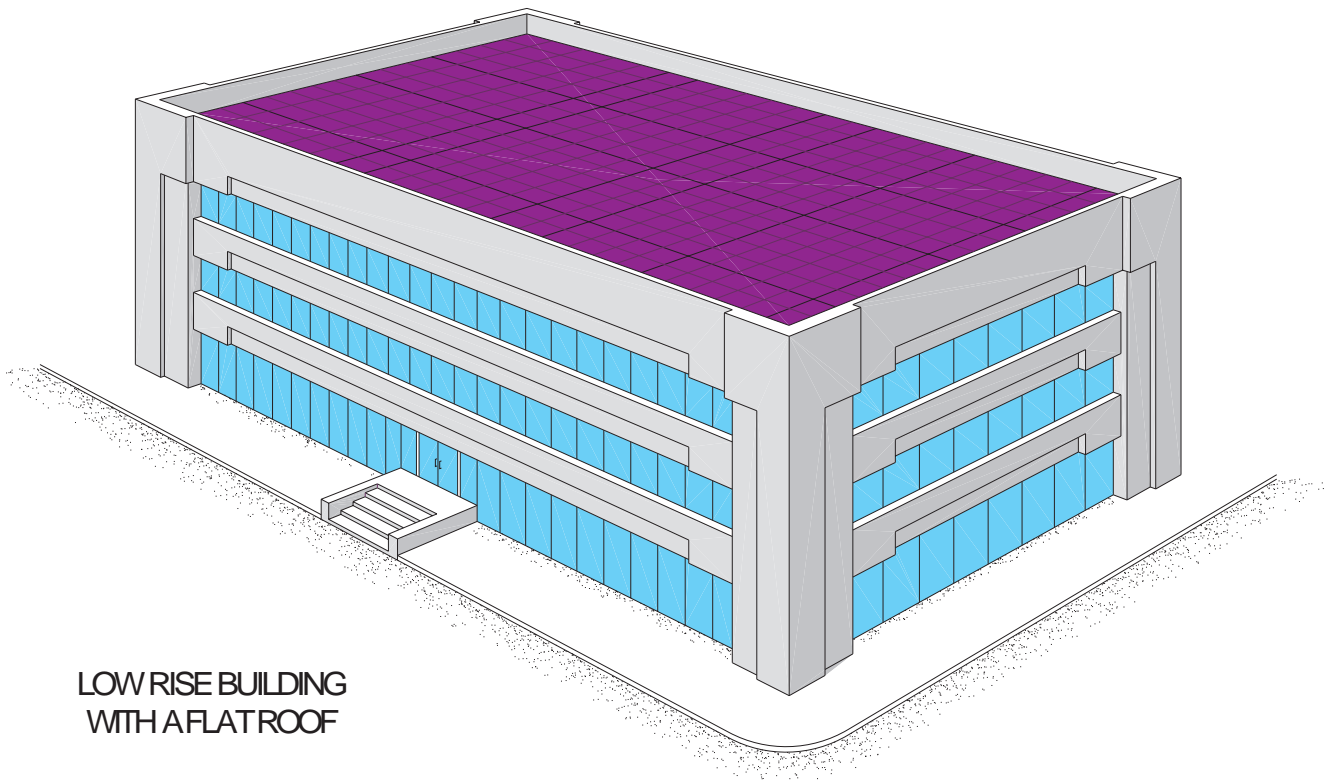

LOW RISE BUILDING  
WITH A FLAT ROOF

PERSPECTIVE : LOW RISE MULTI-STOREY BUILDINGS

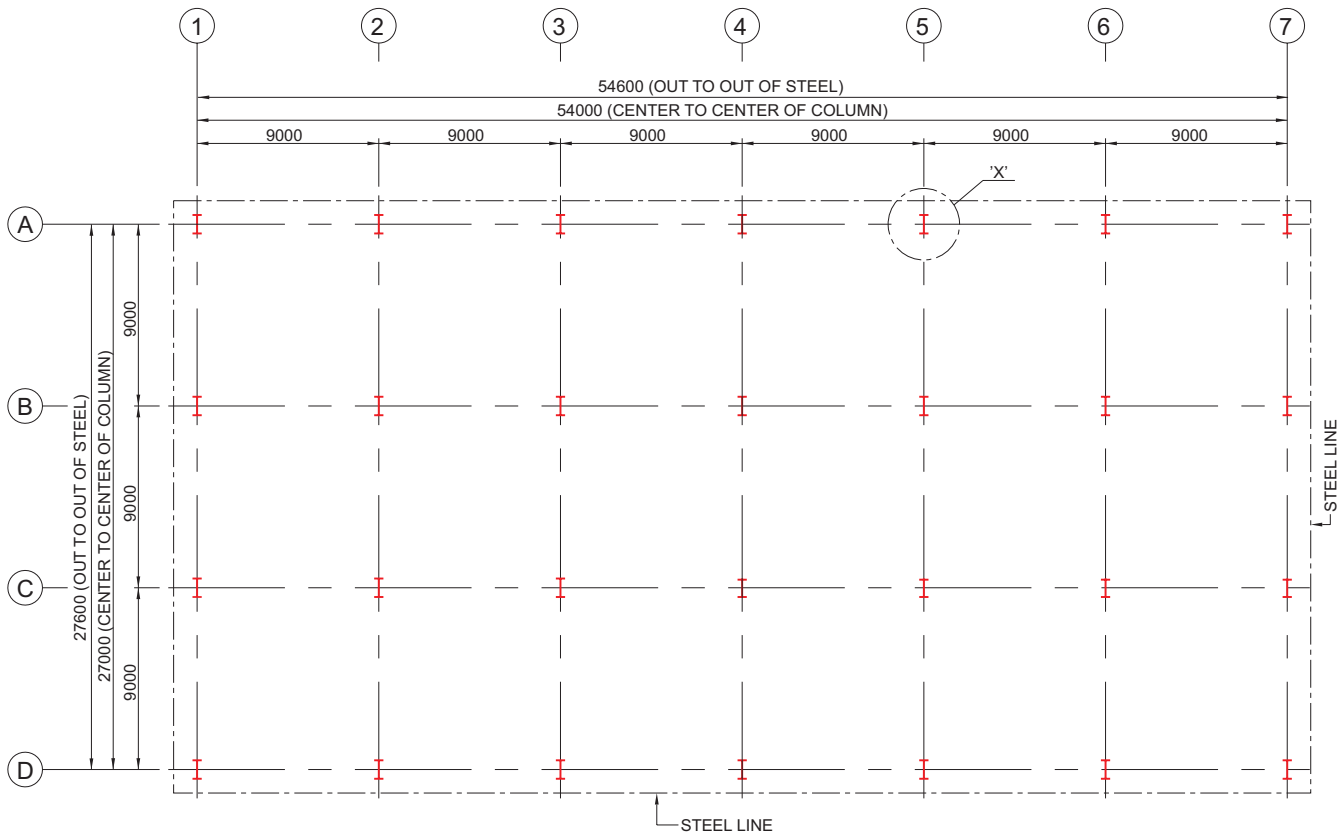

**PLAN** : GROUND FLOOR COLUMN LAYOUT

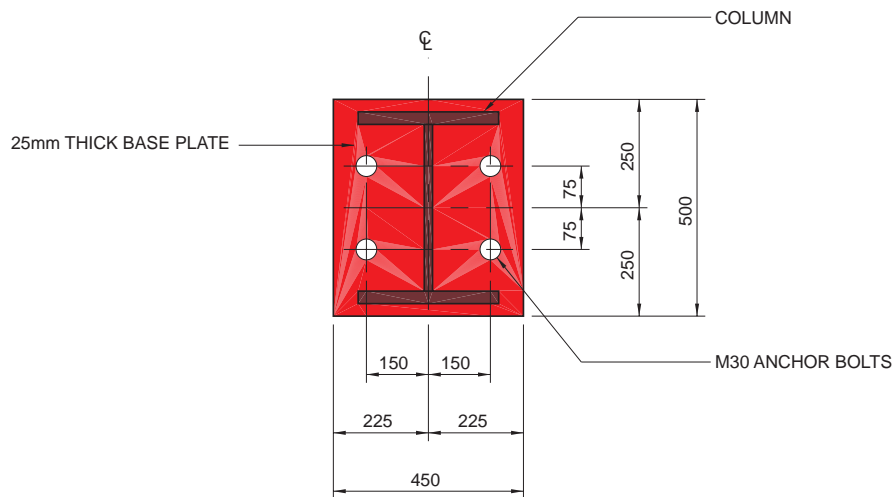

**DETAIL-X** : TYPICAL COLUMN BASE

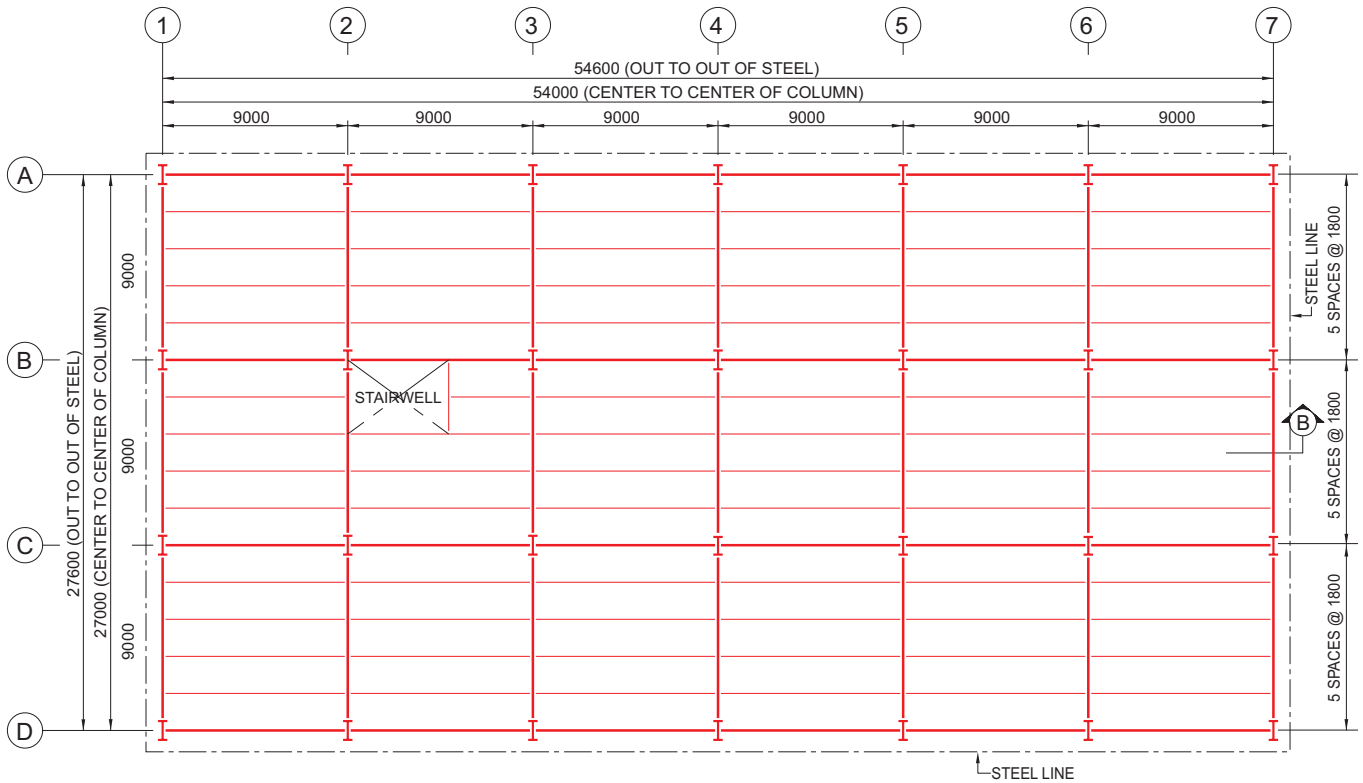

**PLAN** : FIRST AND SECOND FLOOR FRAMING

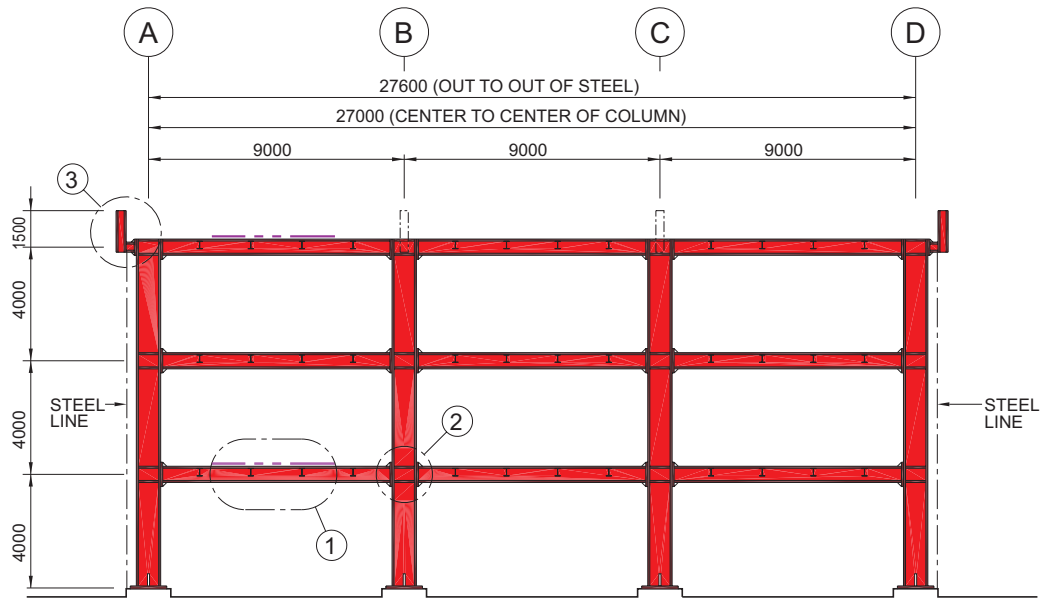

**ELEVATION** : LOW RISE BUILDING FRAMES



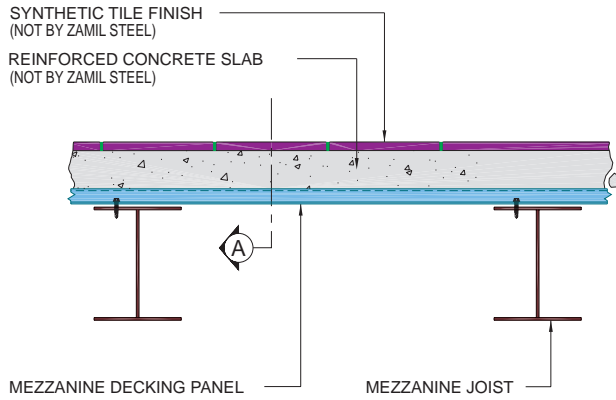

DETAIL-1

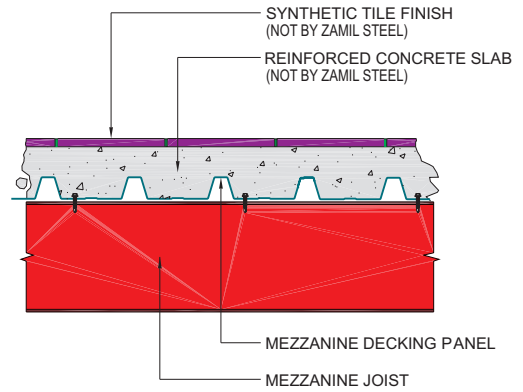

SECTION-A

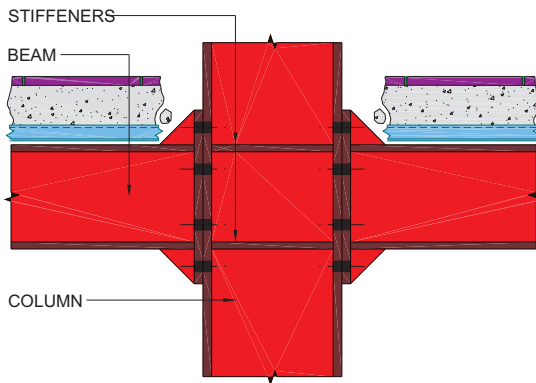

DETAIL-2

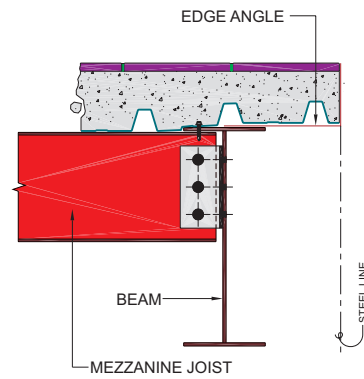

SECTION-B

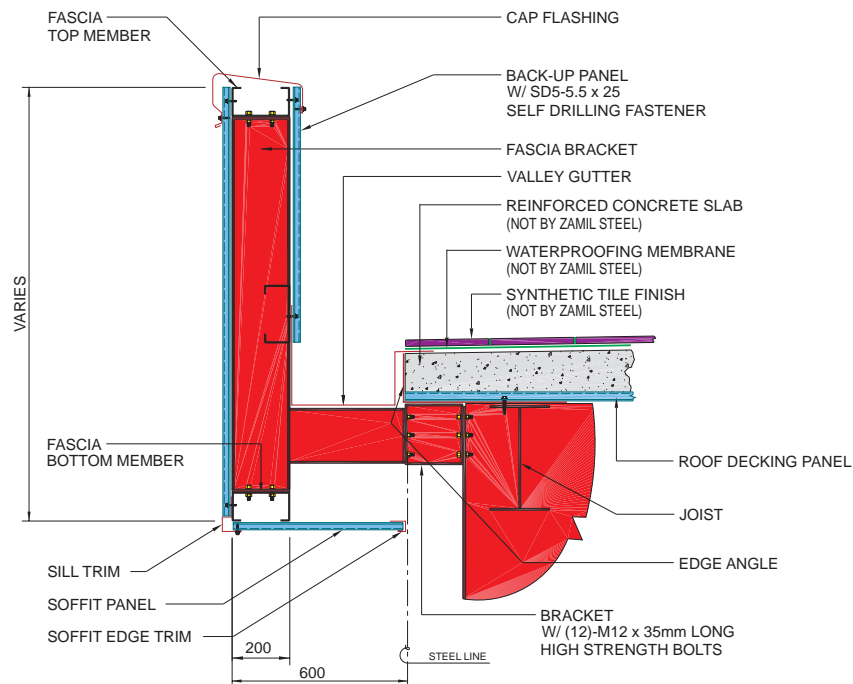

DETAIL-3: CONSTRUCTION AT FASCIA



# SECONDARY STRUCTURAL FRAMING

# C H A P T E R 6

## **6. Secondary Structural Framing**

<b>6.1</b>	<b>General .....</b>	<b>101</b>
<b>6.2</b>	<b>Cold-Formed “Z” Sections .....</b>	<b>102</b>
<b>6.3</b>	<b>Cold-Formed “C” Sections .....</b>	<b>104</b>
<b>6.4</b>	<b>Cold-Formed Eave Strut Section .....</b>	<b>107</b>
<b>6.5</b>	<b>Secondary Framing Details .....</b>	<b>108</b>

**Purlins, girts and eave struts** are secondary structural members used to support the wall and roof panels. Purlins are used on the roof; girts are used on the walls and eave struts are used at the intersection of the sidewall and the roof.

Secondary members have two other functions: they act as struts that help in resisting part of the longitudinal loads that are applied on the building such as wind and earthquake loads, and they provide lateral bracing to the compression flanges of the main frame members thereby increasing frame capacity.

Purlins, girts and eave struts are designed in accordance with the 1986 Edition of the American Iron and Steel Institute (AISI), "Cold-Formed Steel Design Manual".

Purlins, girts and eave struts are available in two standard surface finishes and in six standard thicknesses as shown in the below table:

Zincalume finish can be made available upon request and subject to extended delivery. Zincalume finish for secondary members is available only in thicknesses ranging from 1.5 mm to 2.0 mm and is in accordance with ASTM A792 Grade 50B.

Purlins are bolted to the top flanges of rafters and to each other at purlin laps by means of machine bolts conforming to ASTM A307 M Type A.

Roof and wall panels are laid perpendicular to the

roof purlins and wall girts, respectively, and fastened to them by means of self-drilling fasteners.

For Clear Span (CS) and Multi-Span (MS) buildings the sidewall girts are by-pass connected (by-framed) to the outer flanges of the exterior columns and are lapped at each interior rigid frame column.

For Space Saver (SV) and Lean-To (LT) buildings, the sidewall girts are flush-connected (flush-framed) so that the outer flange of the girt is in the same plane as the outer flange of the exterior columns.

Endwall girts of all standard buildings are flush-connected so that the outer flanges of the girts are in the same plane as the outer flanges of the endwall posts.

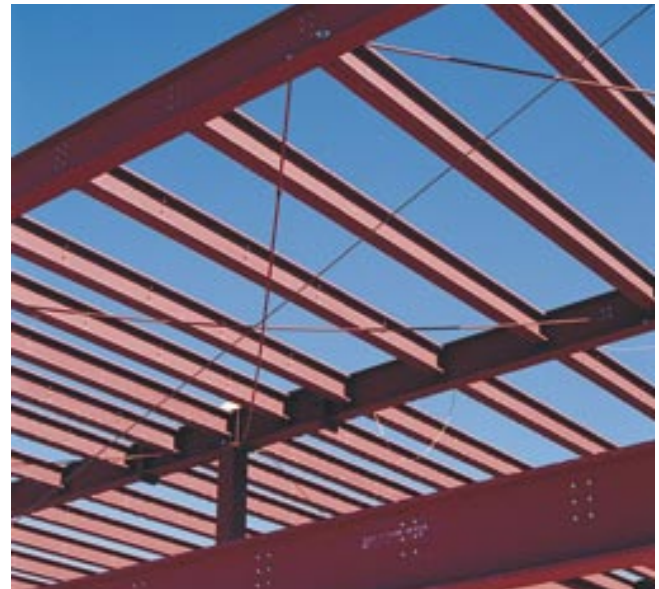

Standard Material Surface Finish	Specifications (equivalent to)	Available Thicknesses (mm)		
		Purlins/Girts		Eave Struts
		Z-Sections	C-Sections	
Red Oxide(Primer)	ASTM A607 Grade 50	1.5, 1.75, 2.0, 2.25, 2.5, 3.0	2.0, 2.5, 3.0	2.0, 2.5
Pre-Galvanized	ASTM A653 Grade SS50, Class I	1.5, 1.75, 2.0, 2.25, 2.5	2.0, 2.5	2.0, 2.5

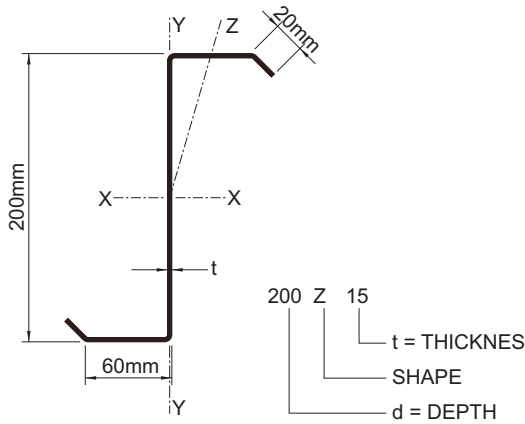

**NOTES:**

1. DIMENSIONS ARE OUT TO OUT OF SECTION THICKNESS, t.
2. ALL SECTIONS ARE DESIGNED IN ACCORDANCE WITH THE COLD-FORMED STEEL DESIGN MANUAL, AISI 1986 EDITION.
3. SPECIFIC YIELD STRENGTH "F<sub>y</sub>" OF LIGHT GAUGE COLD-FORMED STEEL = 34.50 kN/cm<sup>2</sup>
4. COIL WIDTH FOR THICKNESSES 1.5 mm, 1.75 mm, 2.0 mm, 2.25 mm, 3.0 mm = 345 mm

### Section Properties

Section	About X-X Axis				About Y-Y Axis				Others	
	I <sub>x</sub> (cm <sup>4</sup> )	Gross S <sub>xc</sub> = S <sub>x</sub> (cm <sup>3</sup> )	Effect. S <sub>xc</sub> (cm <sup>3</sup> )	R <sub>x</sub> (cm)	I <sub>y</sub> (cm <sup>4</sup> )	I <sub>yc</sub> (cm <sup>4</sup> )	S <sub>y</sub> (cm <sup>3</sup> )	R <sub>y</sub> (cm)	I <sub>xy</sub> (cm <sup>4</sup> )	R <sub>min</sub> (cm)
200Z15	308.3	30.83	26.28	7.72	42.49	21.25	5.98	2.87	83.08	1.91
200Z17	358.8	35.88	31.50	7.71	49.86	24.93	7.01	2.87	97.11	1.92
200Z20	409.1	40.91	38.49	7.70	57.30	28.65	8.05	2.88	111.20	1.92
200Z22	459.1	45.91	44.41	7.69	64.83	32.41	9.10	2.89	125.34	1.93
200Z25	509.0	50.90	50.90	7.68	72.43	36.22	10.16	2.90	139.52	1.93
200Z30	607.9	60.79	60.79	7.66	87.88	43.94	12.32	2.91	168.03	1.94

Section	General Data					Allowable Shear force (kN)	Allowable Bending Moment (kN.m)	
	Weight (kg/m)	Thick (mm)	Area (cm <sup>2</sup> )	Effect. area (cm <sup>2</sup> )	H/t		Ma	Ma2*
200Z15	4.06	1.50	5.18	4.90	123.33	10.33	5.43	5.07
200Z17	4.74	1.75	6.04	5.77	105.43	16.44	6.51	6.07
200Z20	5.42	2.00	6.90	6.74	92.00	24.61	7.95	7.42
200Z22	6.09	2.25	7.76	7.66	81.56	35.14	9.17	8.56
200Z25	6.77	2.50	8.62	8.62	73.20	45.59	10.51	9.81
200Z30	8.12	3.00	10.35	10.35	60.67	65.65	12.56	11.72

\* Based on a reduction factor of 0.70 for continuous spans and an increase of 33% on allowable stress for wind load applications. (Applicable only if the span of the longest member is not more than 20% longer than the shortest span). For simple spans multiply Ma2 values by 0.4/0.7.

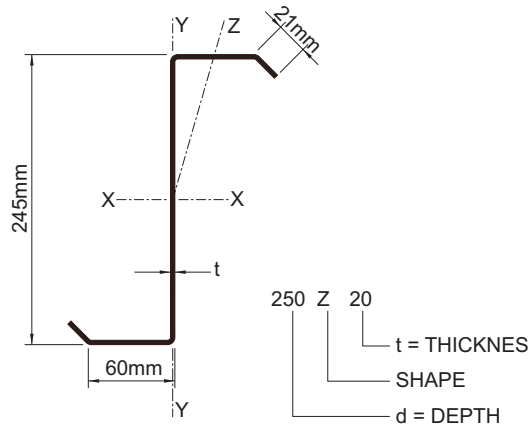

NOTES:

1. DIMENSIONS ARE OUT TO OUT OF SECTION THICKNESS, t.
2. ALL SECTIONS ARE DESIGNED IN ACCORDANCE WITH THE COLD-FORMED STEEL DESIGN MANUAL, AISI 1986 EDITION.
3. SPECIFIC YIELD STRENGTH "Fy" OF LIGHT GAUGE COLD-FORMED STEEL = 34.50 kN/cm<sup>2</sup>
4. COIL WIDTH FOR THICKNESSES 2.0 mm AND 2.5 mm = 390 mm

Section Properties

Section	About X-X Axis				About Y-Y Axis				Others	
	Ix (cm <sup>4</sup> )	Gross (cm <sup>3</sup> )	Effect. Sxc = Sx (cm <sup>3</sup> )	Rx Sxc (cm)	Iy (cm <sup>4</sup> )	Iyc (cm <sup>4</sup> )	Sy (cm <sup>3</sup> )	Ry (cm)	Ixy (cm <sup>4</sup> )	Rmin (cm)
250Z20	661.5	54.00	51.64	9.21	56.78	28.39	8.10	2.70	136.40	1.88
250Z25	823.7	67.24	67.24	9.19	71.72	35.86	10.22	2.71	171.21	1.89

Section	General Data					Allowable Shear force (kN)	Allowable Bending Moment (kN.m)	
	Weight (kg/m)	Thick (mm)	Area (cm <sup>2</sup> )	Effect. area (cm <sup>2</sup> )	H/t		Ma	Ma2*
250Z20	6.12	2.00	7.80	7.67	114.50	19.77	10.67	9.96
250Z25	7.65	2.50	9.75	9.75	91.20	38.79	13.89	12.97

\* Based on a reduction factor of 0.70 for continuous spans and an increase of 33% on allowable stress for wind load applications. (Applicable only if the span of the longest member is not more than 20% longer than the shortest span). For simple spans multiply Ma2 values by 0.4/0.7.

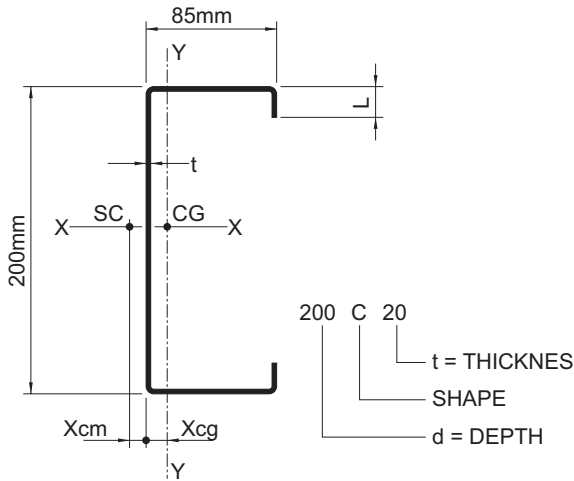

NOTES:

1. DIMENSIONS ARE OUT TO OUT OF SECTION THICKNESS, t.
2. ALL SECTIONS ARE DESIGNED IN ACCORDANCE WITH THE COLD-FORMED STEEL DESIGN MANUAL, AISI 1986 EDITION
3. SPECIFIC YIELD STRENGTH "F<sub>y</sub>" OF LIGHT GAUGE COLD-FORMED STEEL = 34.50 kN/cm<sup>2</sup>
4. C.G. = CENTER OF GRAVITY
5. S.C. = SHEAR CENTER
6. COIL WIDTH = 390 mm

### Section Properties

Section	About X-X Axis					About Y-Y Axis					Others	
	Gross I <sub>x</sub> (cm <sup>4</sup> )	Defl. I <sub>x</sub> (cm <sup>4</sup> )	Gross S <sub>x</sub> (cm <sup>3</sup> )	Eff. S <sub>x</sub> (cm <sup>4</sup> )	R <sub>x</sub> (cm)	I <sub>y</sub> (cm <sup>4</sup> )	I <sub>yc</sub> (cm <sup>4</sup> )	Min. S <sub>y</sub> (cm <sup>3</sup> )	Max. S <sub>y</sub> (cm <sup>3</sup> )	R <sub>y</sub> (cm)	X <sub>cg</sub> (cm)	X <sub>cm</sub> (cm)
200C20	491.7	481.8	49.17	41.45	7.86	73.37	36.69	12.12	29.98	3.07	2.447	3.989
200C25	610.6	609.9	61.06	53.71	7.91	91.76	45.88	15.19	37.32	3.07	2.459	4.016

Section	General Data						Allowable Shear Force (kN)	Allowable Bending Moment (kN.m)	
	Weight (kg/m)	Thick (mm)	L (mm)	Gross Area (cm <sup>2</sup> )	Effect Area (cm <sup>2</sup> )	H/t		Ma	Ma2*
200C20	6.11	2.0	20.0	7.80	7.28	92.0	25.03	8.56	4.55
200C25	7.64	2.5	21.2	9.75	9.23	73.2	45.98	11.10	5.91

\* Based on a reduction factor of 0.40 for simple spans with one unbraced compression side and an increase of 33% on allowable stress for wind load application.



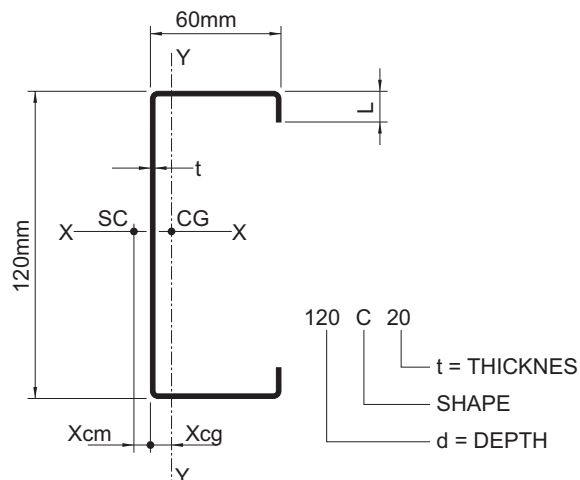

**NOTES:**

1. DIMENSIONS ARE OUT TO OUT OF SECTION THICKNESS, t.
2. ALL SECTIONS ARE DESIGNED IN ACCORDANCE WITH THE COLD-FORMED STEEL DESIGN MANUAL, AISI 1986 EDITION.
3. SPECIFIC YIELD STRENGTH "Fy" OF LIGHT GAUGE COLD-FORMED STEEL = 34.50 kN/cm<sup>2</sup>
4. C.G. = CENTER OF GRAVITY
5. S.C. = SHEAR CENTER
6. COIL WIDTH = 260 mm

### Section Properties

Section	About X-X Axis					About Y-Y Axis					Others	
	Gross I <sub>x</sub> (cm <sup>4</sup> )	Defl. I <sub>x</sub> (cm <sup>4</sup> )	Gross S <sub>x</sub> (cm <sup>3</sup> )	Eff. S <sub>x</sub> (cm <sup>3</sup> )	R <sub>x</sub> (cm)	I <sub>y</sub> (cm <sup>4</sup> )	I <sub>yc</sub> (cm <sup>4</sup> )	Min. S <sub>y</sub> (cm <sup>3</sup> )	Max. S <sub>y</sub> (cm <sup>3</sup> )	R <sub>y</sub> (cm)	X <sub>cg</sub> (cm)	X <sub>cm</sub> (cm)
120C20	120.25	120.25	20.04	20.04	4.81	25.97	12.99	6.58	12.67	2.24	2.050	2.921
120C25	148.51	148.51	24.76	24.76	4.78	32.34	16.71	8.26	15.51	2.23	2.085	2.924
120C30	175.98	175.98	29.33	29.33	4.75	38.67	19.33	9.97	18.23	2.23	2.121	2.924

Section	General Data						Allowable Shear Force (kN)	Allowable Bending Moment (kN.m)	
	Weight (kg/m)	Thick (mm)	L (mm)	Gross Area (cm <sup>2</sup> )	Effect Area (cm <sup>2</sup> )	H/t		Ma	Ma2*
120C20	4.08	2.0	17.43	5.20	5.20	55.00	29.38	3.21	1.71
120C25	5.10	2.5	18.65	6.50	6.50	43.60	37.57	4.04	2.15
120C30	6.12	3.0	19.86	7.80	7.80	36.00	44.67	4.85	2.58

\* Based on a reduction factor of 0.40 for simple spans with one unbraced compression side and an increase of 33% on allowable stress for wind load application.

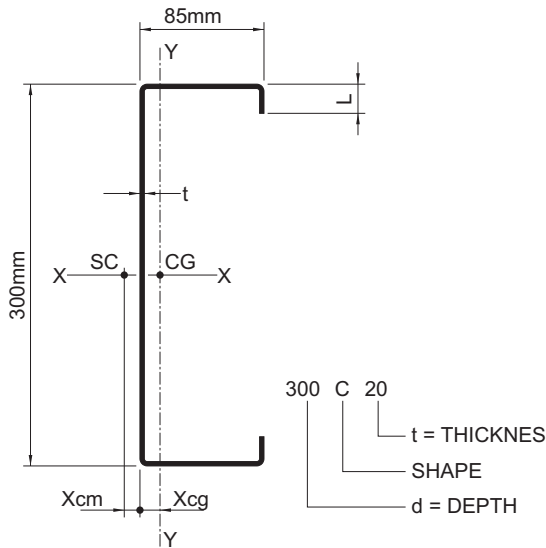

NOTES:

1. DIMENSIONS ARE OUT TO OUT OF SECTION THICKNESS, t.
2. ALL SECTIONS ARE DESIGNED IN ACCORDANCE WITH THE COLD-FORMED STEEL DESIGN MANUAL, AISI 1986 EDITION
3. SPECIFIC YIELD STRENGTH "F<sub>y</sub>" OF LIGHT GAUGE COLD-FORMED STEEL = 34.50 kN/cm<sup>2</sup>
4. C.G. = CENTER OF GRAVITY
5. S.C. = SHEAR CENTER
6. COIL WIDTH = 495 mm

### Section Properties

Section	About X-X Axis					About Y-Y Axis					Others	
	Gross I <sub>x</sub> (cm <sup>4</sup> )	Defl. I <sub>x</sub> (cm <sup>4</sup> )	Gross S <sub>x</sub> (cm <sup>3</sup> )	Eff. S <sub>x</sub> (cm <sup>4</sup> )	R <sub>x</sub> (cm)	I <sub>y</sub> (cm <sup>4</sup> )	I <sub>yc</sub> (cm <sup>4</sup> )	Min. S <sub>y</sub> (cm <sup>3</sup> )	Max. S <sub>y</sub> (cm <sup>3</sup> )	R <sub>y</sub> (cm)	X <sub>cg</sub> (cm)	X <sub>cm</sub> (cm)
300C20	1308.5	1308.5	87.23	74.29	11.50	91.81	45.91	14.55	41.90	3.04	2.19	3.61

Section	General Data						Allowable Shear Force (kN)	Allowable Bending Moment (kN.m)	
	Weight (kg/m)	Thick (mm)	L (mm)	Gross Area (cm <sup>2</sup> )	Effect Area (cm <sup>2</sup> )	H/t		Ma	Ma2*
300C20	7.78	2.0	25.65	9.90	9.14	142.0	15.94	15.34	8.18

\* Based on a reduction factor of 0.40 for simple spans with one unbraced compression side and an increase of 33% on allowable stress for wind load application.

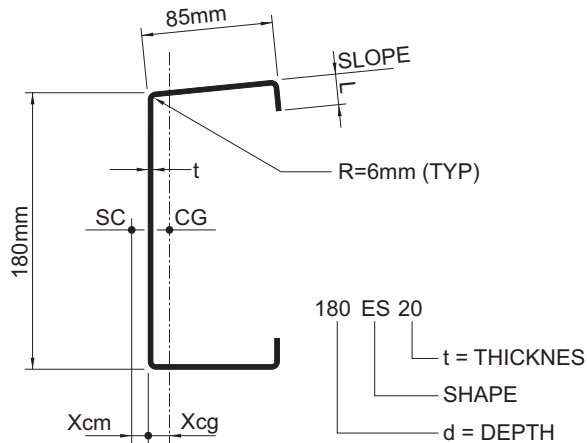

**NOTES:**

1. DIMENSIONS ARE OUT TO OUT OF SECTION THICKNESS, t.
2. ALL SECTIONS ARE DESIGNED IN ACCORDANCE WITH THE COLD-FORMED STEEL DESIGN MANUAL, AISI 1986 EDITION.
3. SPECIFIC YIELD STRENGTH "Fy" OF LIGHT GAUGE COLD-FORMED STEEL = 34.50 kN/cm<sup>2</sup>
4. C.G. = CENTER OF GRAVITY
5. S.C. = SHEAR CENTER
6. COIL WIDTH = 390 mm

### Section Properties

Section	About X-X Axis					About Y-Y Axis					Others	
	Gross I <sub>x</sub> (cm <sup>4</sup> )	Defl. I <sub>x</sub> (cm <sup>4</sup> )	Gross S <sub>x</sub> (cm <sup>3</sup> )	Effec. S <sub>x</sub> (cm <sup>3</sup> )	R <sub>x</sub> (cm)	I <sub>y</sub> (cm <sup>4</sup> )	I <sub>yc</sub> (cm <sup>4</sup> )	Min. S <sub>y</sub> (cm <sup>3</sup> )	Max. S <sub>y</sub> (cm <sup>3</sup> )	R <sub>y</sub> (cm)	X <sub>cg</sub> (cm)	X <sub>cm</sub> (cm)
180ES20	390.5	387.2	43.40	37.00	7.21	74.10	37.10	12.70	27.90	3.14	2.656	4.217
180ES25	484.1	484.3	53.80	48.45	7.19	92.50	46.30	15.90	34.70	3.14	2.667	4.244

Section	General Data						Allowable Shear Force (kN)	Allowable Bending Moment (kN.m)	
	Weight (kg/m)	Thick (mm)	L (mm)	Gross Area (cm <sup>2</sup> )	Effect Area (cm <sup>2</sup> )	H/t		Ma	Ma2*
180ES20	5.88	2.0	22.50	7.50	7.00	82.0	28.09	7.65	4.07
180ES25	7.35	2.5	26.70	9.38	8.93	65.20	45.98	10.01	5.33

\* Based on a reduction factor of 0.40 for simple spans with one unbraced compression side and an increase of 33% on allowable stress for wind load application.

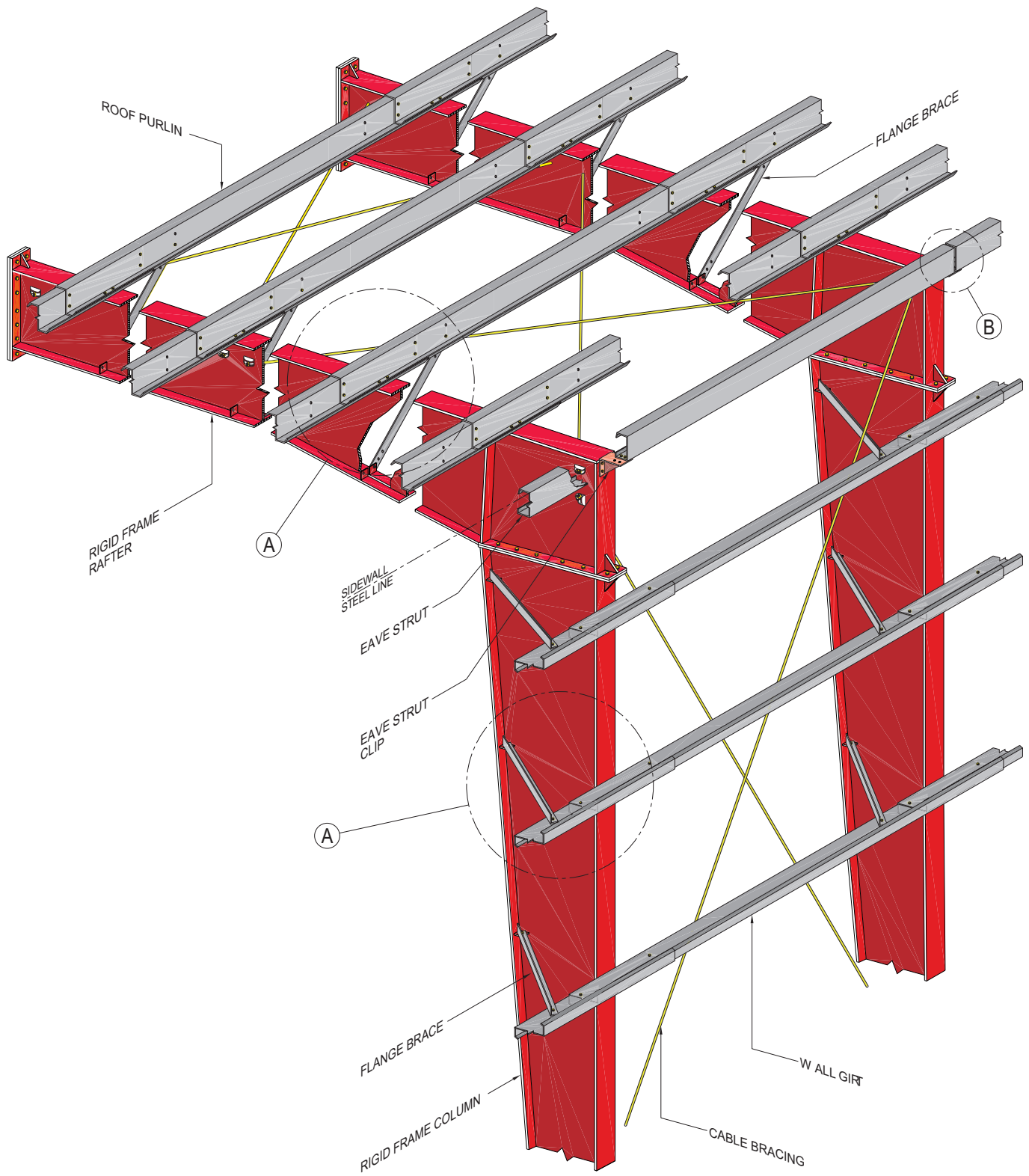

**ISOMETRIC**: ROOF AND SIDEWALL FRAMING DETAIL WITH STD. PURLIN, GIRT AND EAVE STRUT CONNECTION

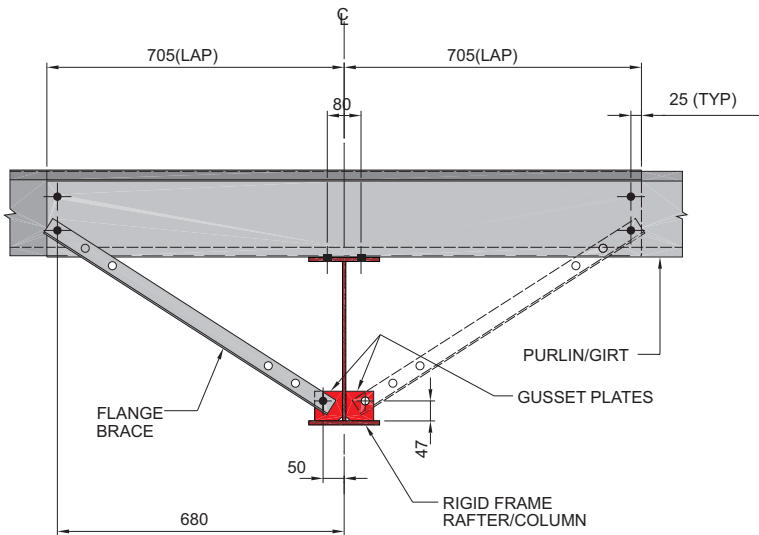

**DETAIL-A** : PURLIN/GIRT WITH LONG LAP

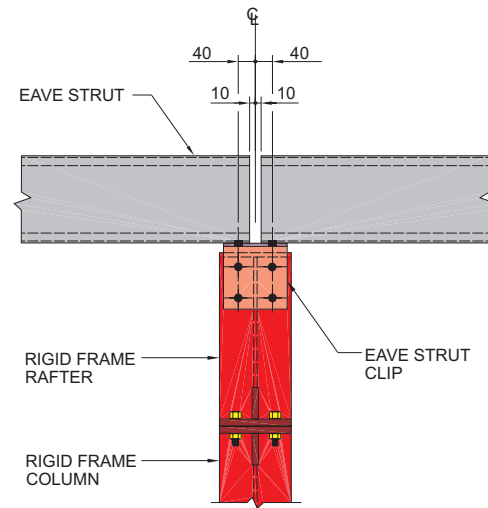

**DETAIL-B** : STANDARD EAVE STRUT CONNECTION

NOTE:  
 1. ALL BOLTS ARE M12 MILD STEEL BOLTS  
 2. FOR RAFTER WITH WEB DEPTH THAT IS MORE THAN ONE METER AN ADDITIONAL FLANGE BRACE IS ADDED AS SHOWN IN BROKEN LINES.

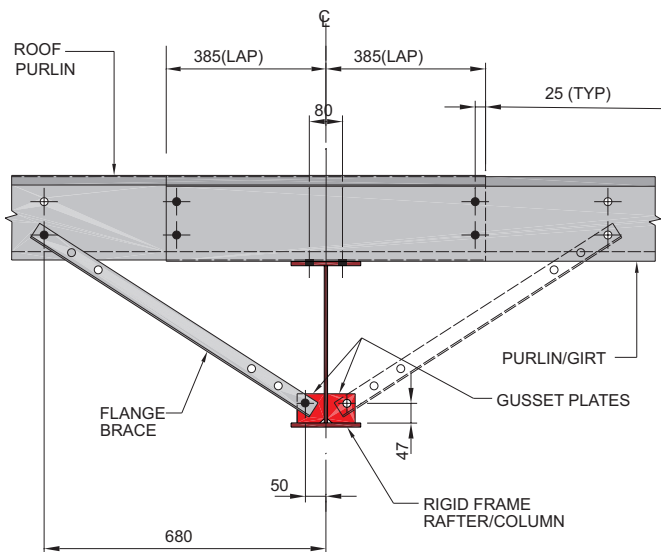

**DETAIL-C** : PURLIN/GIRT WITH CONTINUOUS LAP

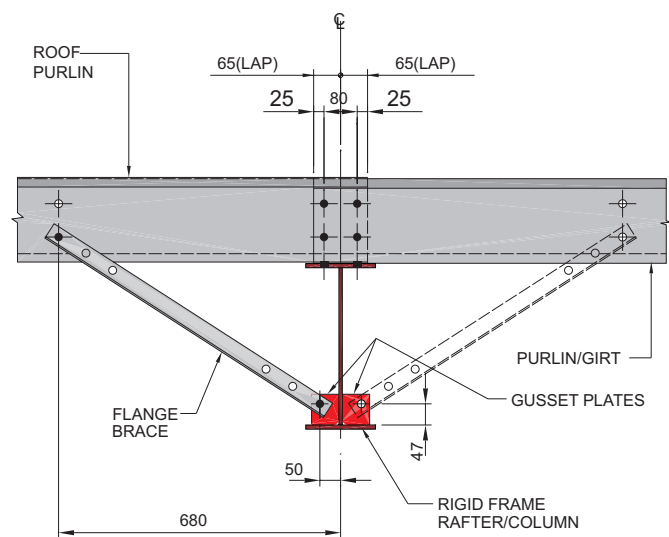

**DETAIL-D** : PURLIN/GIRT WITH SHORT LAP

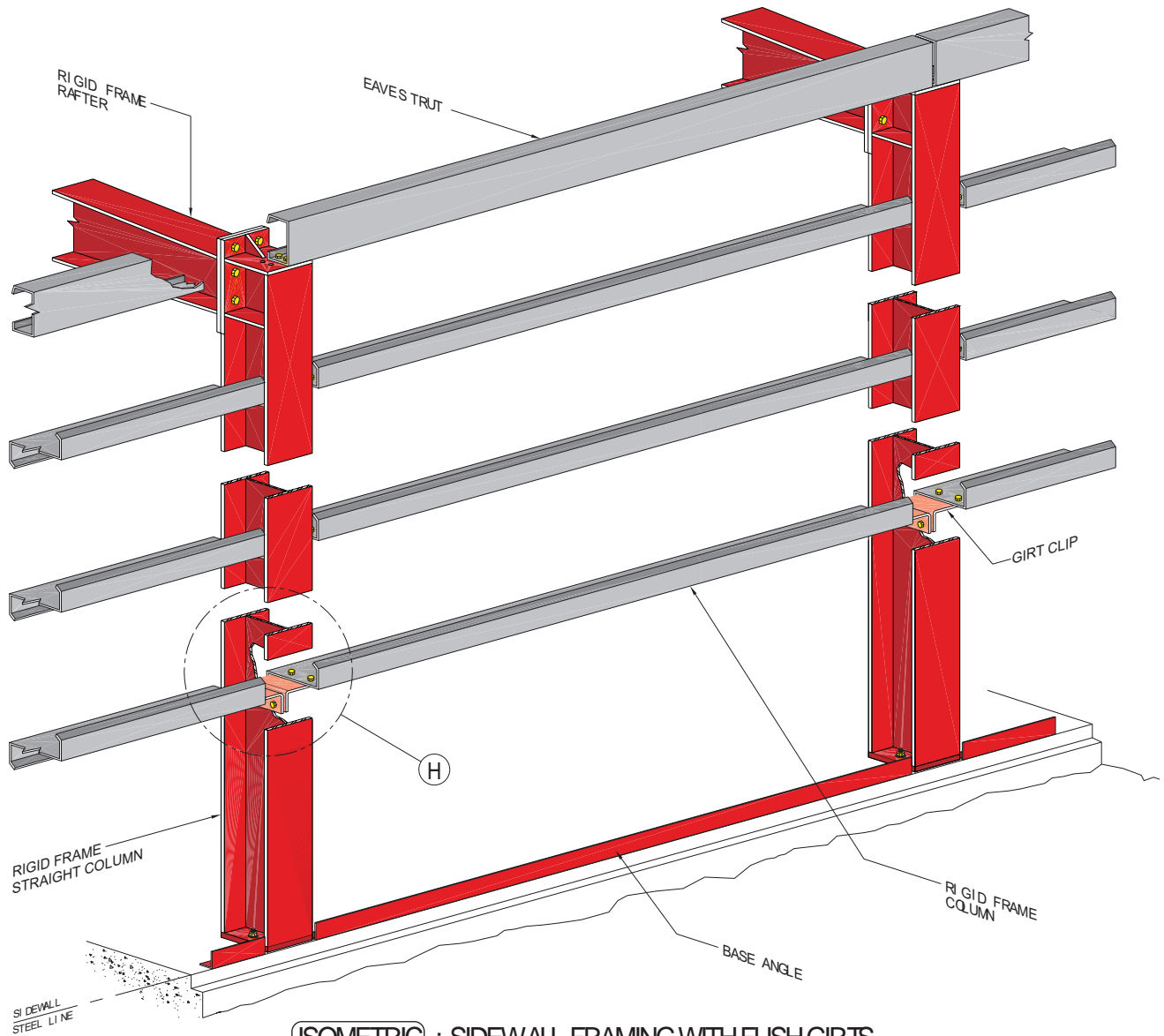

**ISOMETRIC** : SIDEWALL FRAMING WITH FLUSH GIRTS

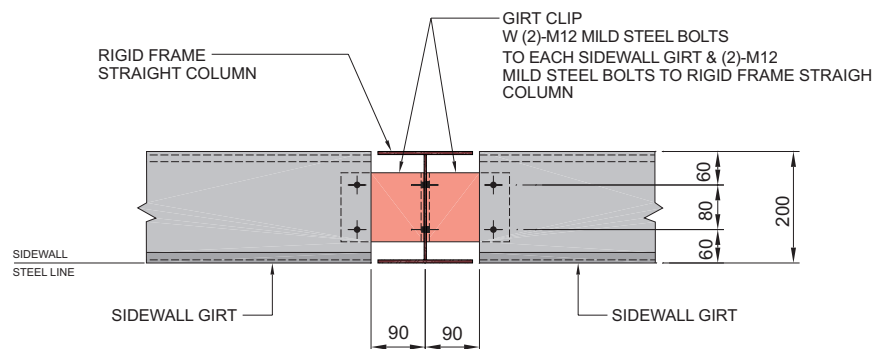

**DETAIL-H**: FLUSH SIDEWALL GIRTS AT RIGID FRAME STRAIGHT COLUMN

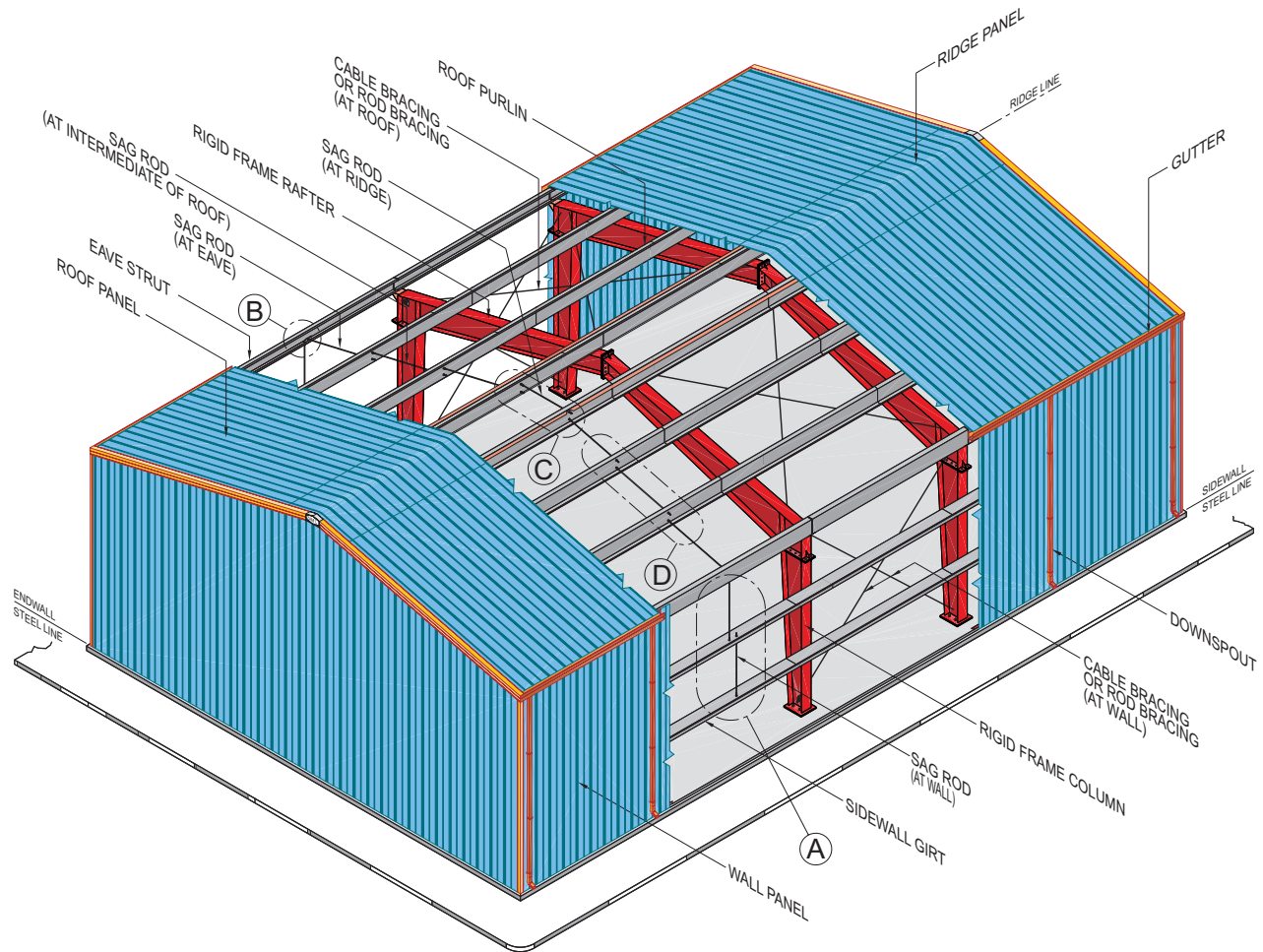

**ISOMETRIC** : SAG ROD AT BAYS EXCEEDING 8.5 METERS SPACING

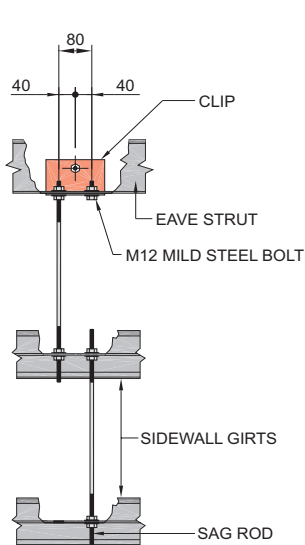

**DETAIL-A** : SAG ROD AT WALL

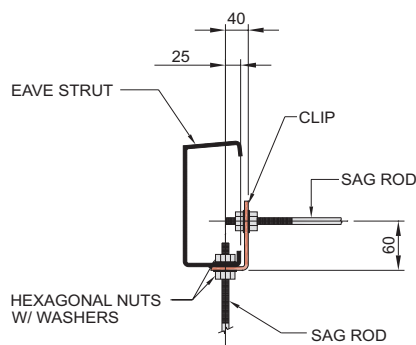

**DETAIL-B** : SAG ROD AT EAVE

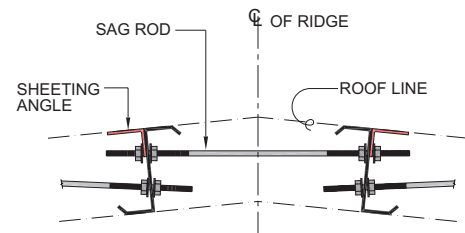

**DETAIL-C** : SAG ROD AT RIDGE

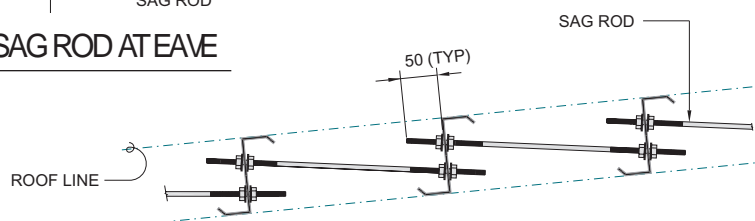

**DETAIL-A** : SAG ROD AT ROOF





# **BASIC STRUCTURAL SUBSYSTEMS**

# **C H A P T E R 7**

# 7. Basic Structural Subsystems

7.1	General .....	115
7.2	Bracing .....	116
7.3	Endwalls .....	119
7.4	Jack Beams .....	134
7.5	Expansion Joints .....	139
7.6	Masonry Conditions .....	144
7.7	Pre-cast Panels .....	146

The strength of the pre-engineered building system lies in its ability to incorporate a large number of structural subsystems that use standard components and standard design approaches to satisfy a wide range of custom requirements.

The structural subsystems that form a basic Zamil Steel pre-engineered building consist of:

- Bracing Systems
- Secondary Members
- Post & Beam Endwalls

Other structural subsystems, which are discussed in **chapter 10**, satisfy two types of requirements:

- Aesthetic (mainly fascias)
- Functional (canopies, roof extensions, partitions, mezzanines, etc.)

This chapter isolates each basic structural subsystem, explains its function and displays the most common details for its use in a Zamil Steel pre-engineered building.

Structural subsystems use the same three basic product categories; built-up “I” sections, cold-formed “Z” sections and cold-formed profiled sheeting panels, to produce economical solutions to functional & aesthetic requirements.

This chapter also displays the standard details adopted by Zamil Steel for these subsystems. These details were developed as a result of the extensive experience gained by Zamil Steel during the past 20 years and have proven, time after time, to result in safe and economical solutions using components that are easy to engineer, easy to fabricate and easy to erect.

Zamil Steel’s extensive engineering resources and capabilities enable us to adopt any proposed detail to meet a customer’s unique requirements.

We recommend that you read the following Zamil Steel publications in conjunction with this chapter:

- Standard Product Specifications
- Panel Chart (colors & profiles)

At Zamil Steel we make it a point to continuously review and enhance the details shown in this chapter. Our purpose is to develop details that are more economical, more fabrication friendly and more erection friendly. We strongly embrace the partnering concept of doing business and we acknowledge that most improvements are the result of feedback from concerned well-meaning customers. Thus, we sincerely solicit your views and suggestions to improve our product and welcome any improvements you may suggest.

All the details in this chapter are current as of the date of this printing. Zamil Steel reserves the right to change or modify these details if and when it deems necessary.



*Lateral stability* along the width of pre-engineered steel buildings is provided by designing the frames to resist the imposed lateral loads.

Bracing systems are furnished along the length of the buildings to provide *longitudinal stability* due to the weakness of the building structure in that direction.

The main purpose of a bracing system is the transmission of lateral forces due to wind, cranes, earthquakes, etc. from their point of application on the structure to the column bases and eventually into the foundations.

Zamil Steel standard bracing systems are Diagonal X-Bracing, Portal Bracing and Minor Axis Bending.

### Diagonal X-Bracing

This is the standard bracing system commonly used in the roof and sidewalls of pre-engineered steel buildings. Members used for the diagonals are galvanized cable strands (Zamil Steel's standard), solid smooth rods, flat bars or angles.

### Portal Bracing

This form of bracing is usually provided between exterior columns at the exterior sidewalls, or between interior columns in very wide Multi-Span and Multi-Gable buildings, in bays where diagonal X-bracing is not permitted due to a desire to have clear non-obstructed deep space through these bays.

Portal frames are made from built-up columns and rafters. Portal frame columns are commonly stitch bolted to the web of the Rigid Frame columns as an alternative to anchoring the portal frame columns to the foundation substructure.

### Minor Axis Bending

In this method the Rigid Frame columns are analyzed as fixed at the base, in the minor axis direction, so as to resist the lateral forces applied along the length of the building.

This system is recommended only in buildings with narrow widths, low eave heights and containing a large number of bays. The lateral force along the eave of the building is divided by the total number of main frame columns, resulting in a force per column that is small enough to be resisted by the sectional properties of the column along its weak axis.

Minor axis bending becomes uneconomical and unsuitable for buildings with large widths, high eave heights, and a small number of bays.

Minor axis bending is most common in shade structures (mostly car parking structures) which require walls to be fully open for access. These structures are usually long, have low eave heights and consist of a large number of bays.



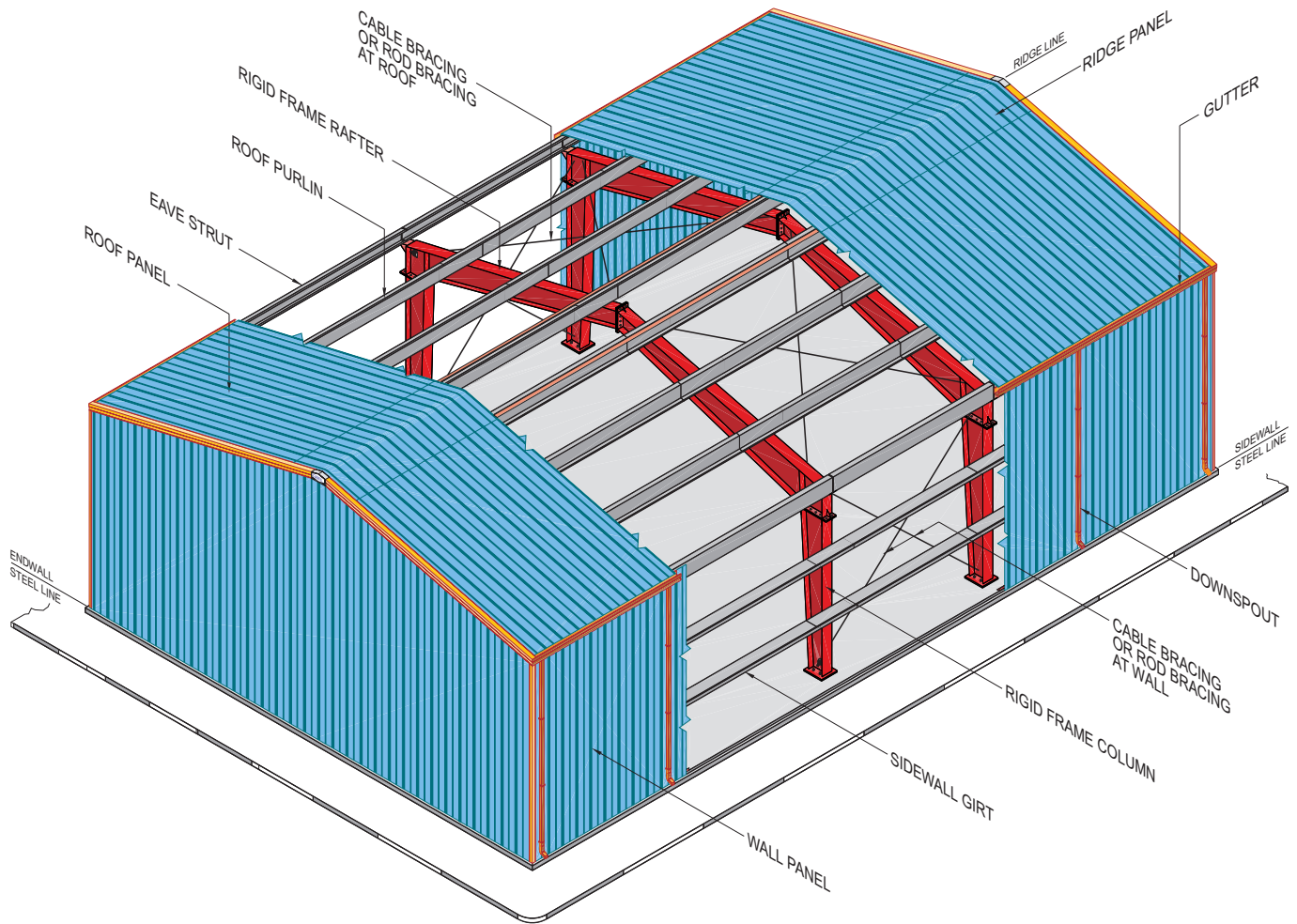

**ISOMETRIC** : CABLE OR ROD BRACING AT ROOF AND WALLS OF A BRACED BAY

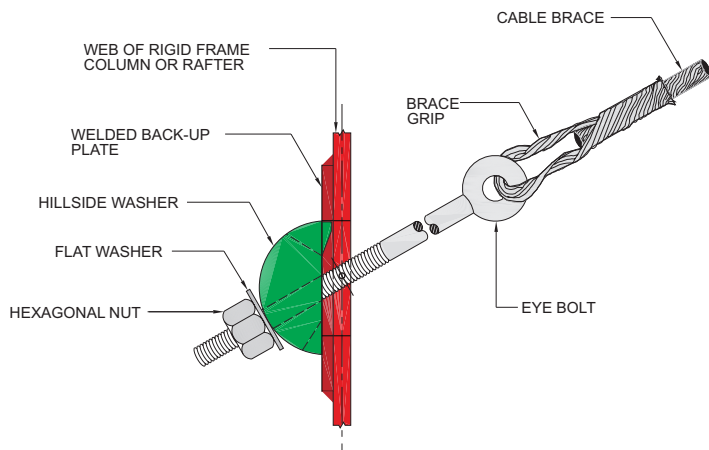

**DETAIL** : CABLE BRACING

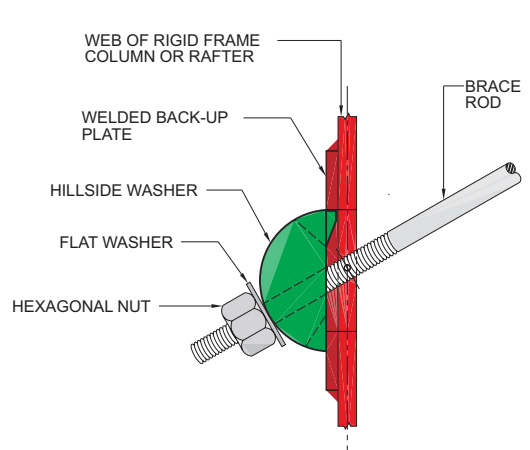

**DETAIL** : ROD BRACING

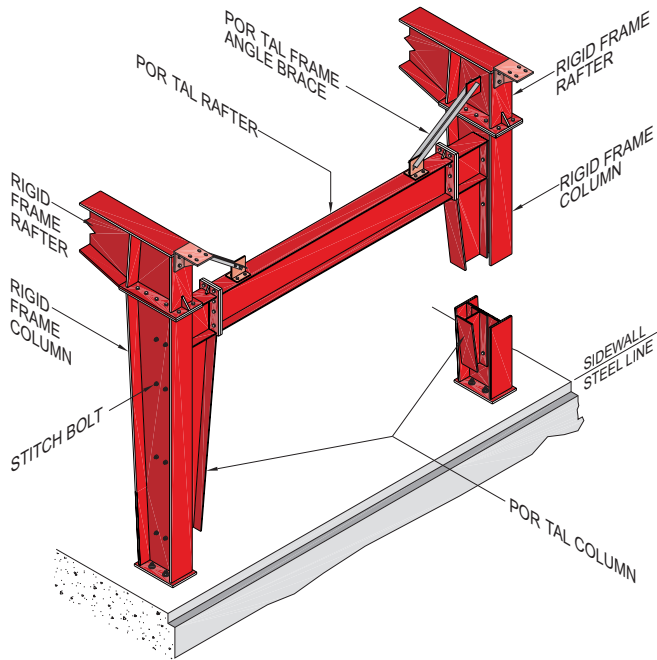

DETAIL : PORTAL FRAME

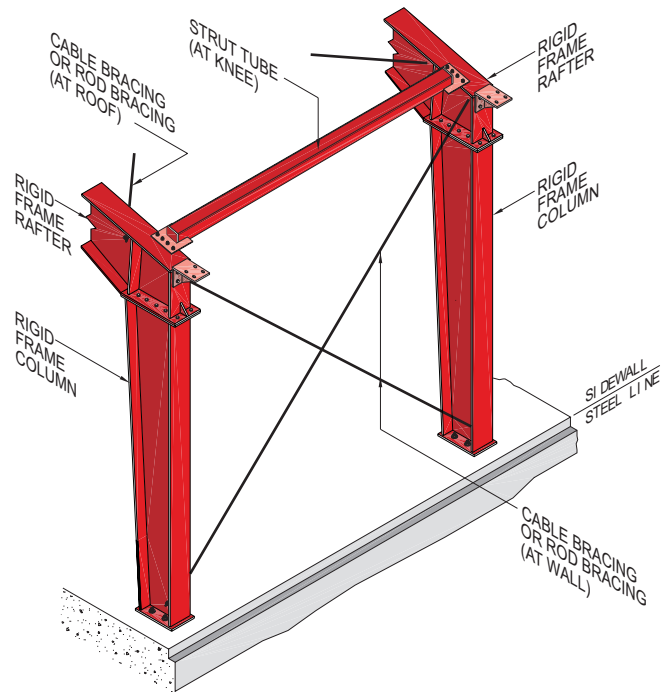

DETAIL : CABLE OR ROD BRACING WITH STRUT TUBE

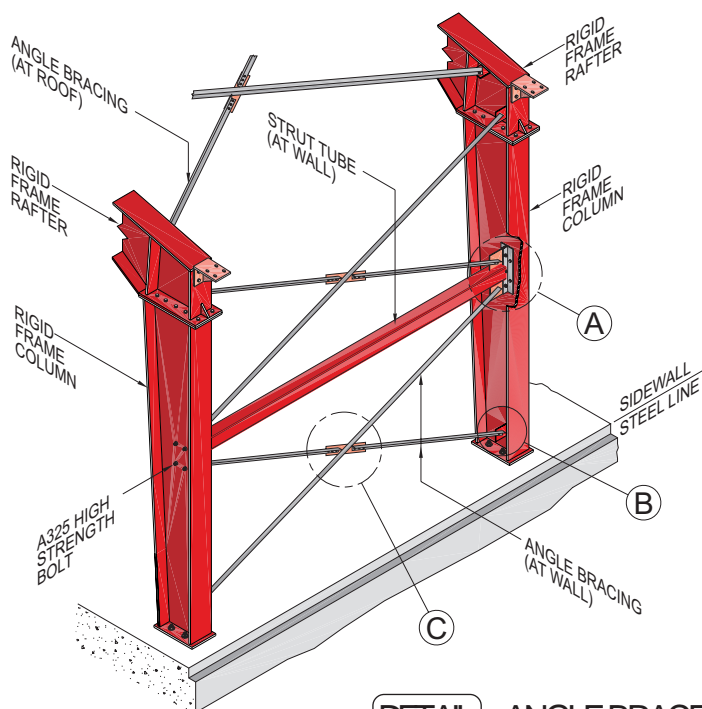

DETAIL : ANGLE BRACE WITH STRUT TUBE

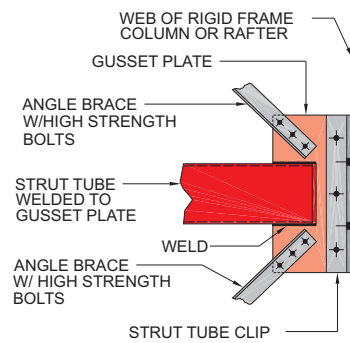

DETAIL-A

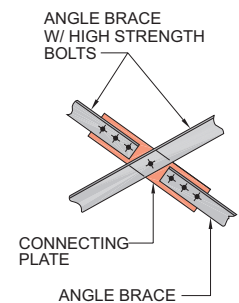

DETAIL-C

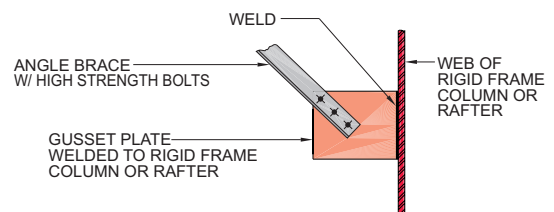

DETAIL-B

The Endwall Frame of a pre-engineered building may be designed as a main **Rigid Frame (R.F.)**, i.e., similar to an interior frame, or as a **Post-and-Beam (P&B)** frame.

### Post-and-Beam Endwall

The Post-and-Beam endwall system of framing consists of columns (posts), with pinned ends, supporting endwall rafters. Girts are flush-framed between posts to provide lateral stability and a neat appearance.

Post-and-Beam endwalls are assumed to be laterally stiff due to the flush-framed girts and the diaphragm effect of the wall sheeting. The diaphragm action is proven to be sufficient enough to resist the transverse wind force acting on the small tributary area of the sidewall.

Where a blockwall is required in place of the wall sheeting, angle clips are provided at certain locations along the posts to tie them to the blockwall in order to ensure the frame's stability. Endwall posts are designed to carry both vertical loads and horizontal wind loads.

### Rigid Frame Endwall

A Rigid Frame endwall is typically used when a building is designed for a future expansion along the length of the building, when a crane system (runway beam) extends to the end of the building or when large unobstructed openings are required in the endwall. This type of frame is usually designed to withstand a full bay load and is normally identical to an interior main rigid frame.

When a main rigid frame is used, a distance of 385 mm is maintained between the centerline of the main frame column and the outside flange of endwall posts (i.e. the endwall steel line). This is to provide sufficient lap for purlins and girts in case of a future expansion. Endwall posts provided in this type of framing system are designed to carry horizontal wind forces only.

Standard endwall post spacing is 6 m, but this may be changed to accommodate special needs such as very wide doors.



FOR DETAILS "1" TO "13" SEE PAGES 3 TO 15 OF THIS SECTION

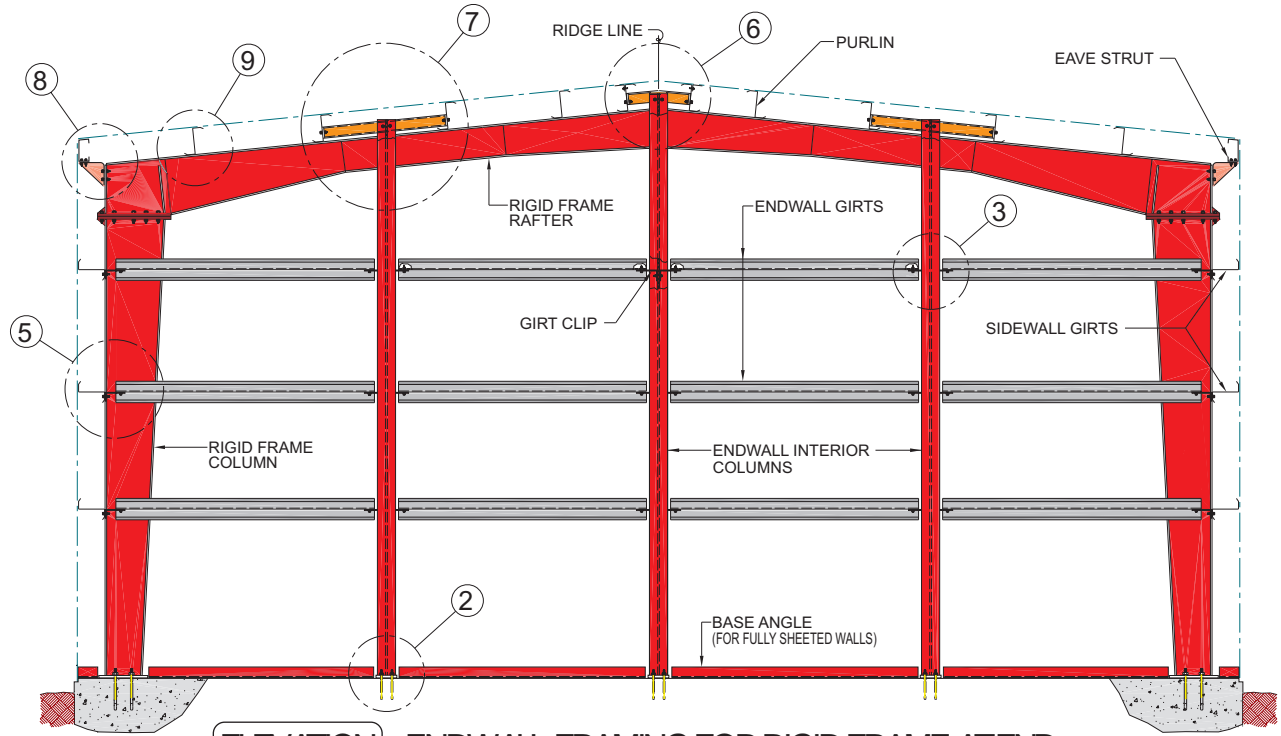

ELEVATION : ENDWALL FRAMING FOR RIGID FRAME AT END

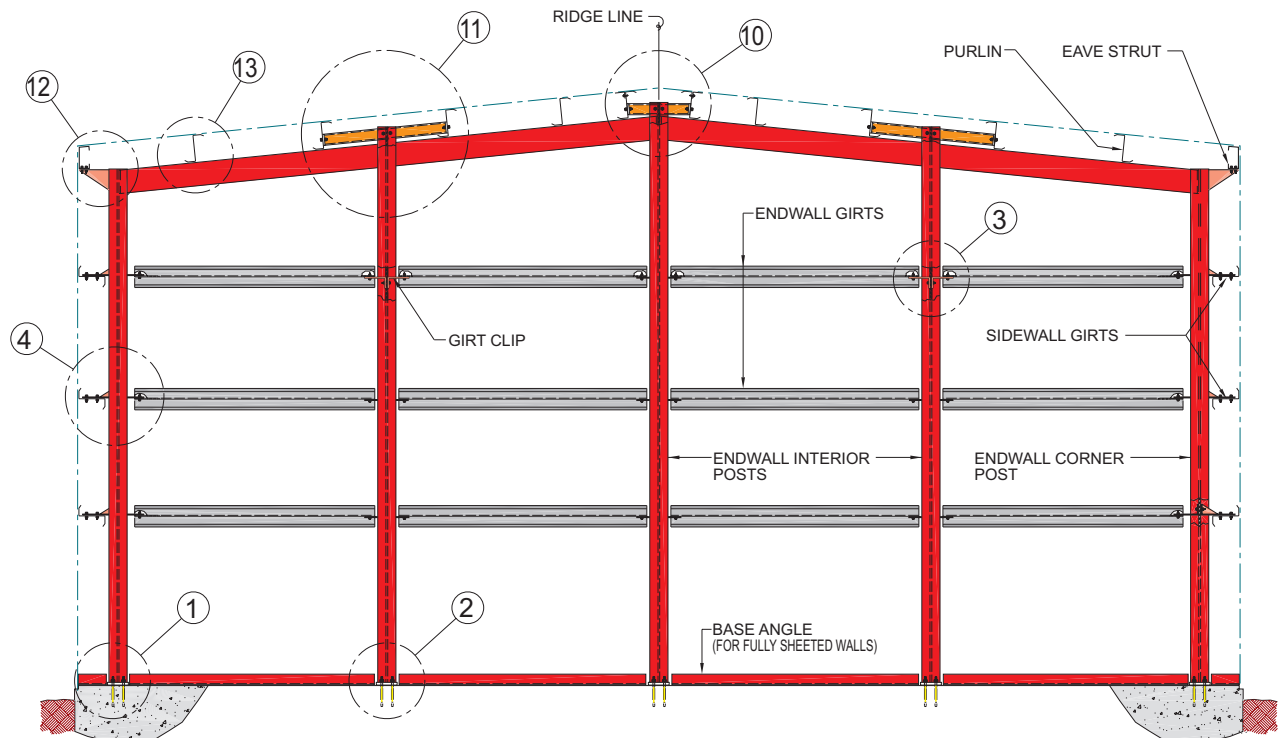

ELEVATION : ENDWALL FRAMING FOR POST AND BEAM AT END



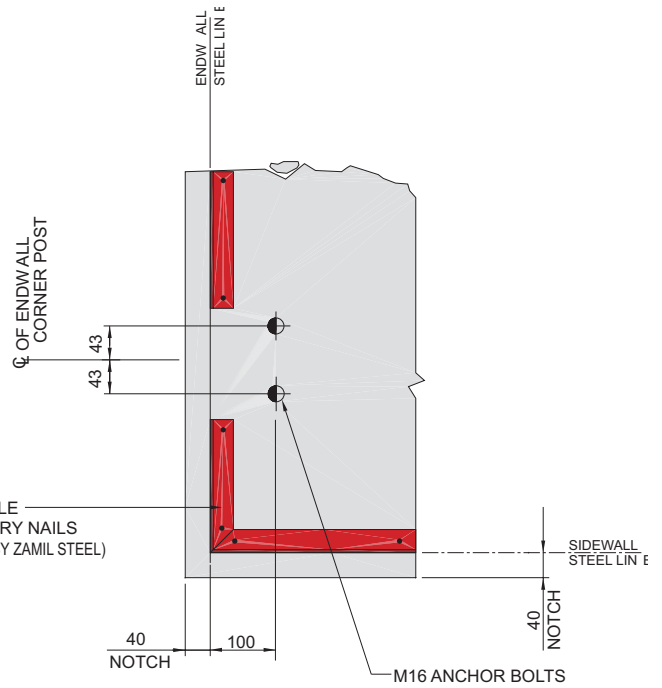
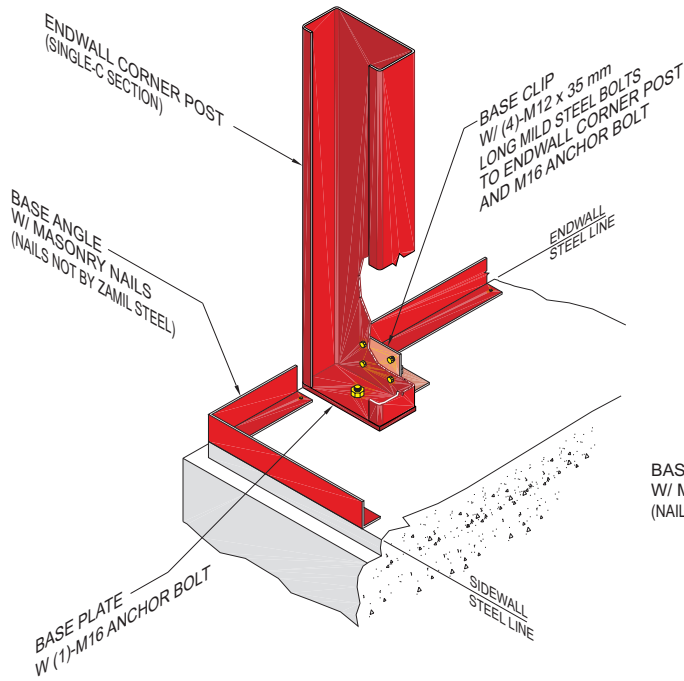

ISOMETRIC : "SINGLE-C" CORNER POST

PLAN

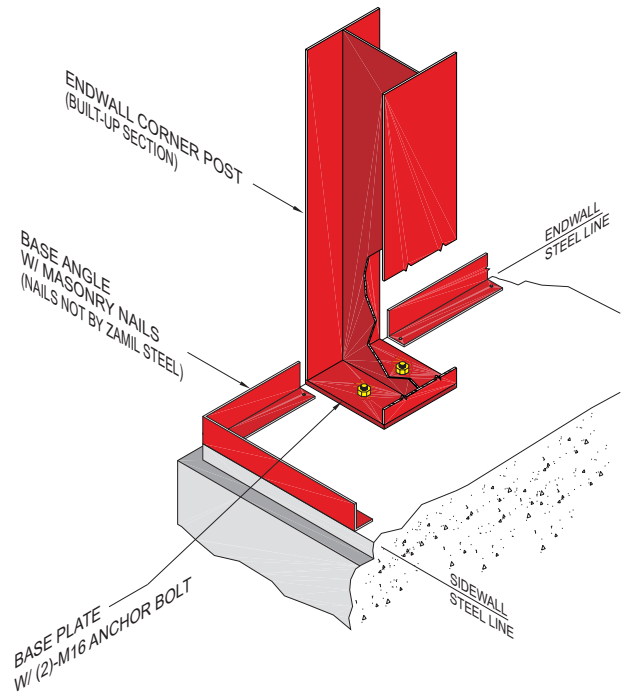
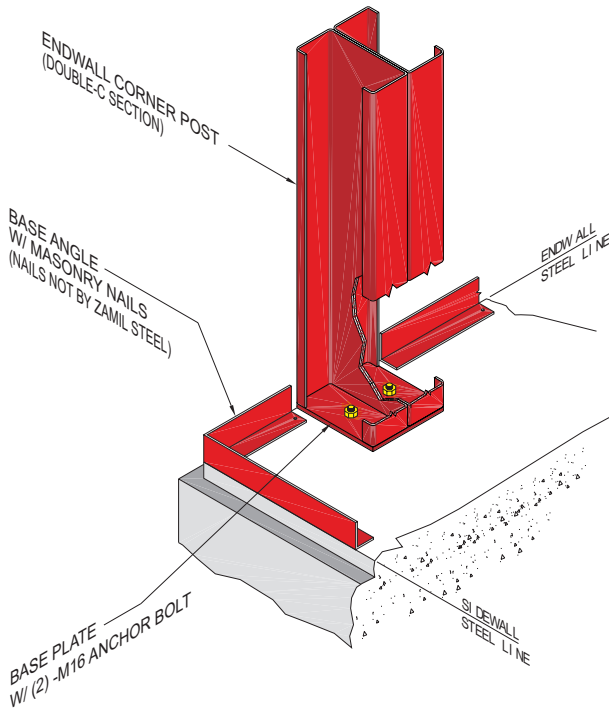

ISOMETRIC : "DOUBLE-C" CORNER POST

ISOMETRIC : "BUILT-UP" CORNER POST

DETAIL - 1 : CORNER POST AT BASE OF P&B ENDWALL

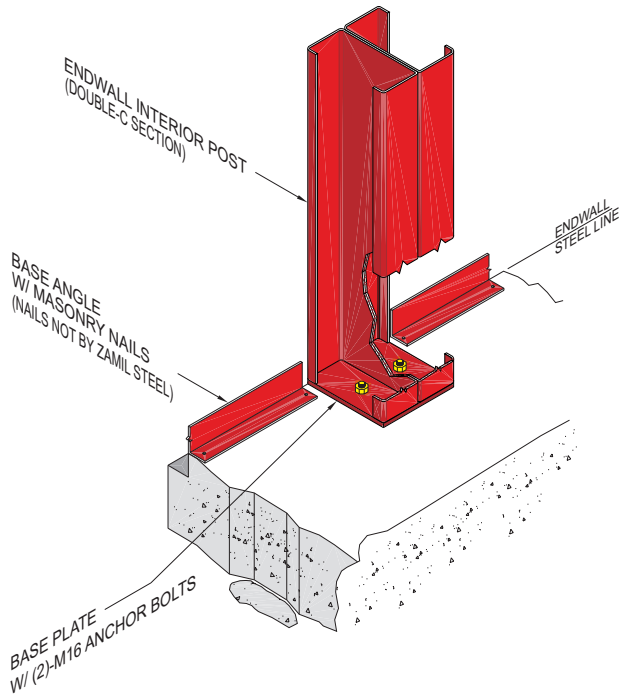

ISOMETRIC : "DOUBLE-C" INTERIOR POST

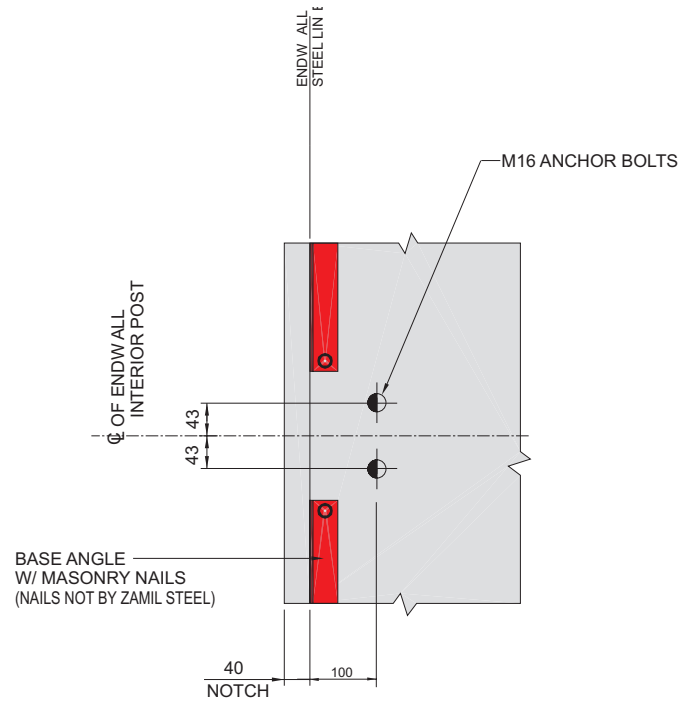

PLAN

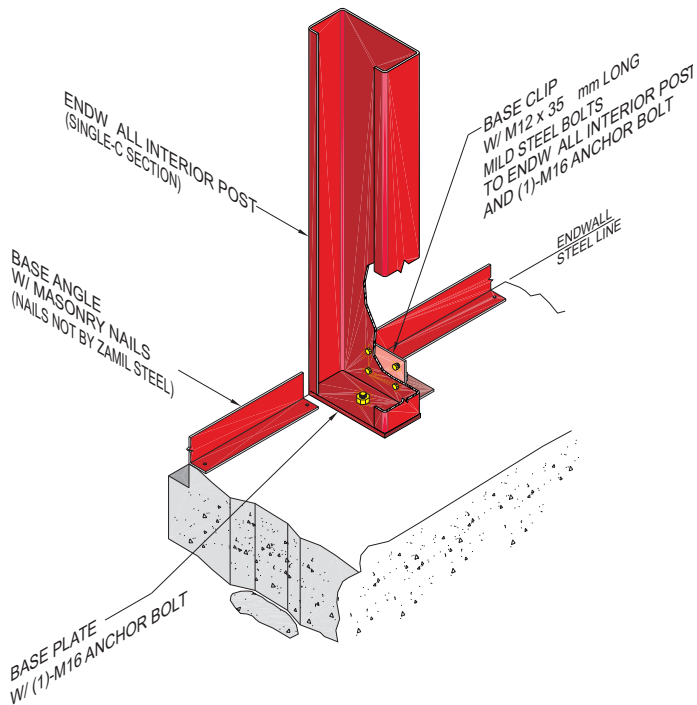

ISOMETRIC : "SINGLE-C" INTERIOR POST

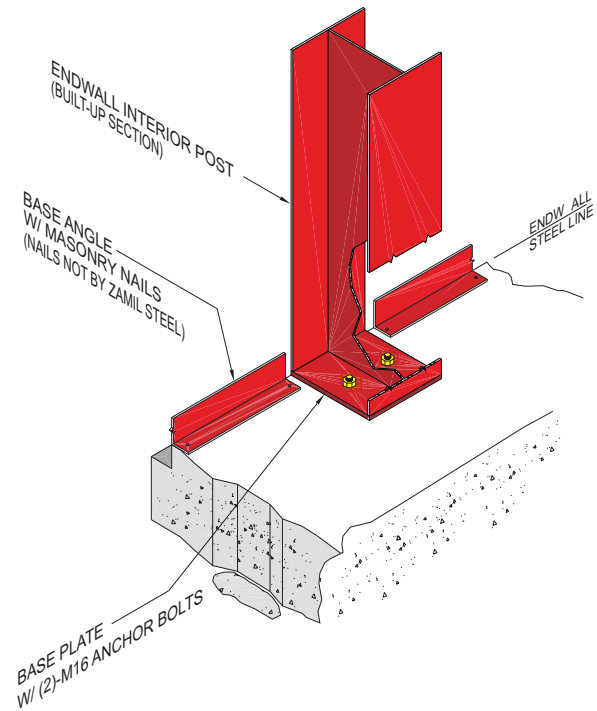

ISOMETRIC : "BUILT-UP" INTERIOR POST

DETAIL-2 : INTERIOR POST AT BASE OF P&B OR R.F. ENDWALL

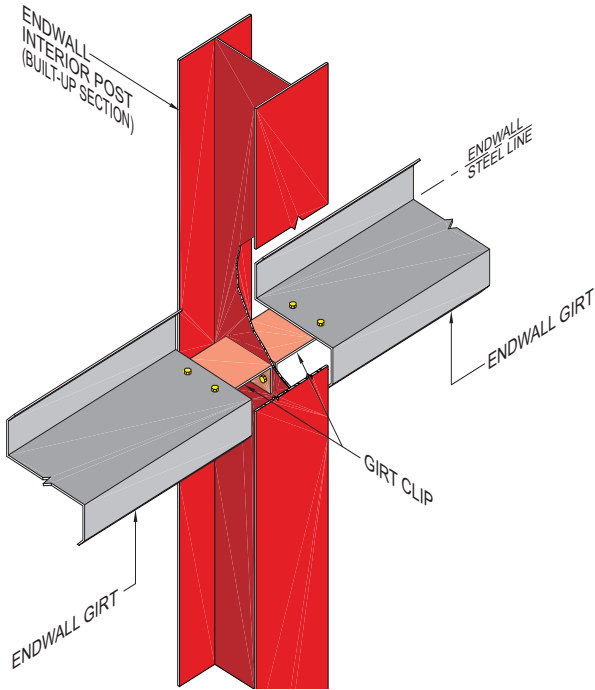

**ISOMETRIC** : "BUILT-UP" INTERIOR POST

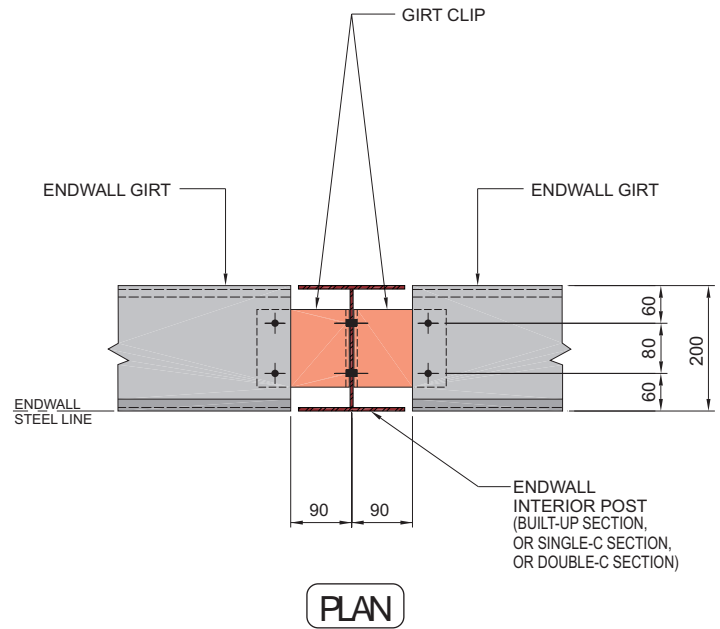

**PLAN**

ALL BOLTS ARE M12 X 35 mm A307 BOLTS

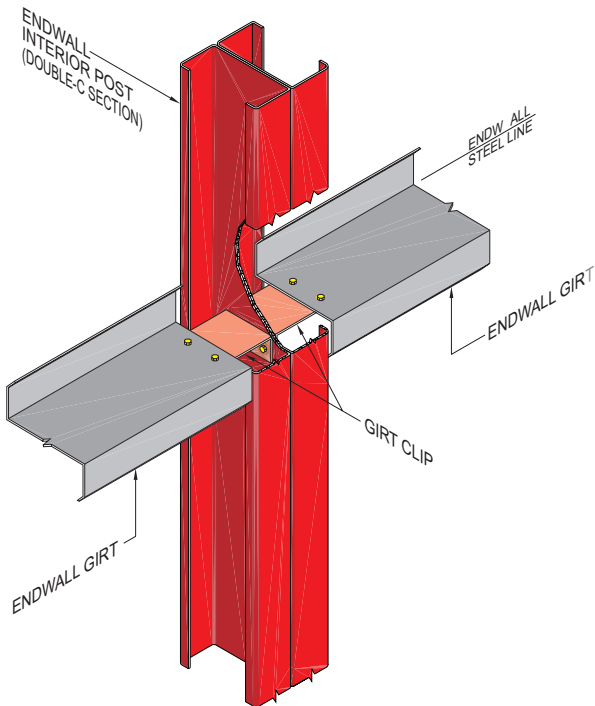

**ISOMETRIC** : "DOUBLE-C" INTERIOR POST

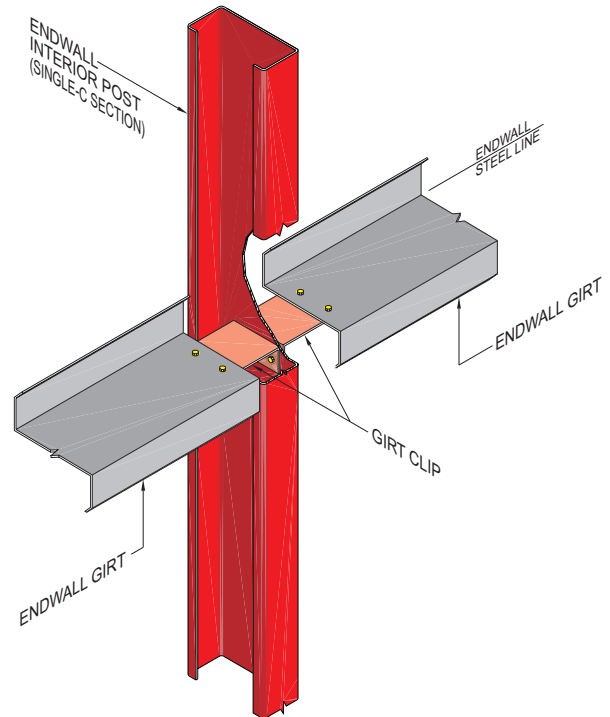

**ISOMETRIC** : "SINGLE-C" INTERIOR POST

**DETAIL-3** : INTERIOR POST AT GIRTS OF P&B OR R.F. ENDWALL

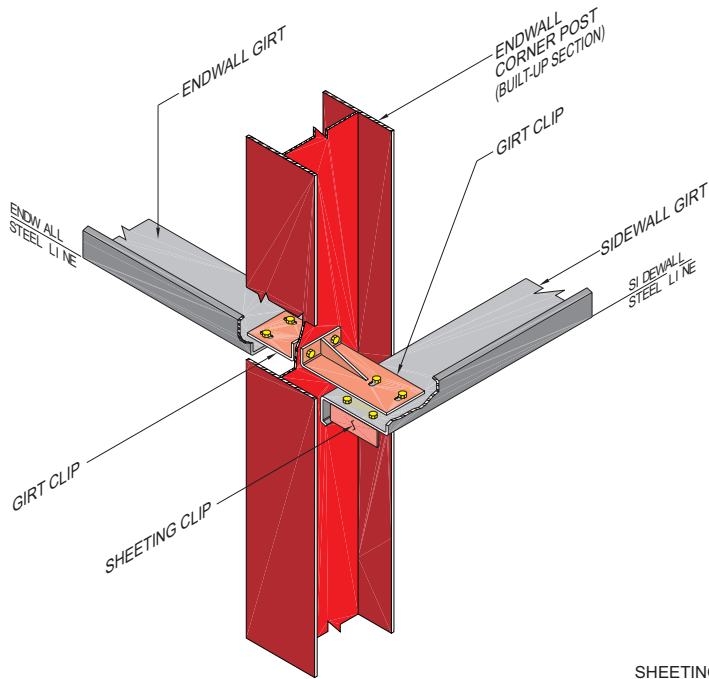

ISOMETRIC : "BUILT-UP" CORNER POST

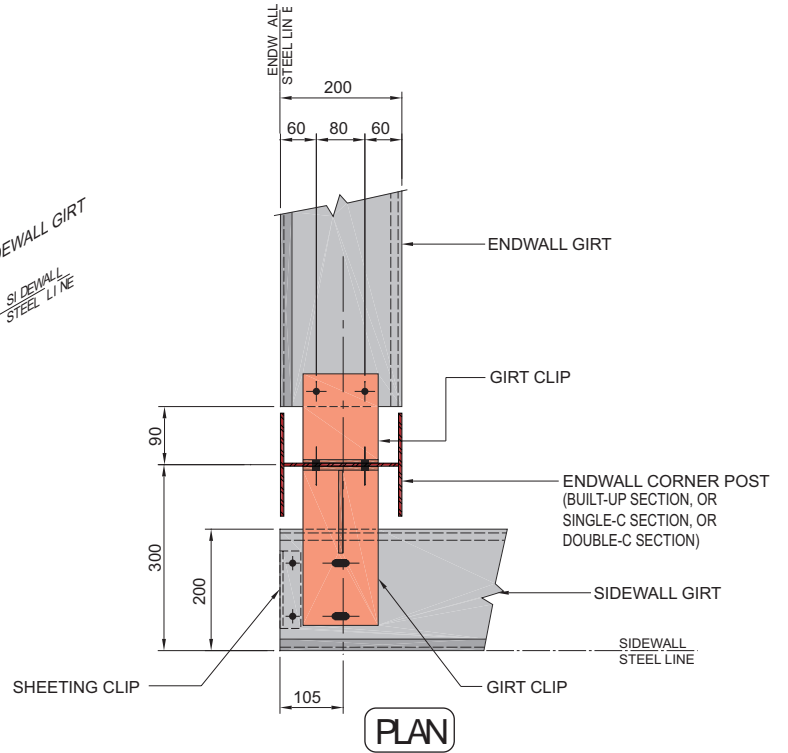

PLAN

ALL BOLTS ARE M12 x 35 mm A307 BOLTS

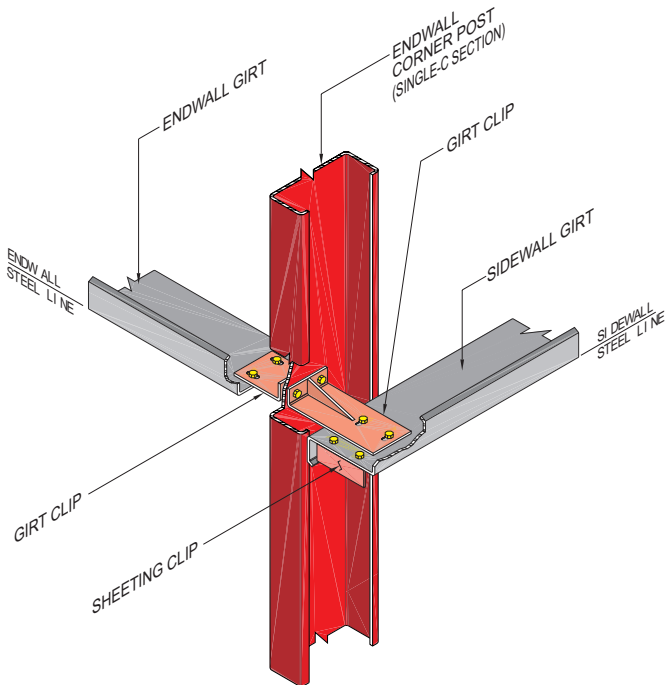

ISOMETRIC : "SINGLE-C" CORNER POST

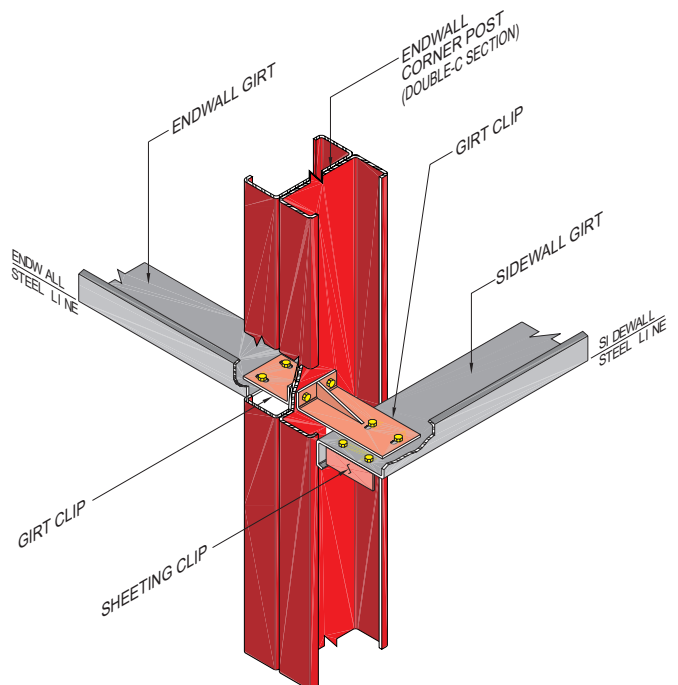

ISOMETRIC : "DOUBLE-C" CORNER POST

DETAIL - 4 : CORNER POST AT GIRTS OF P&B ENDWALL

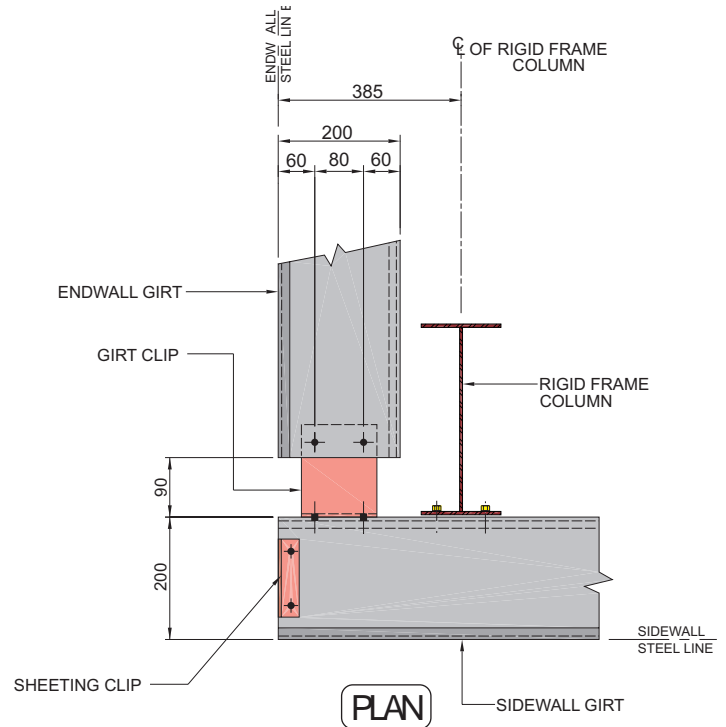
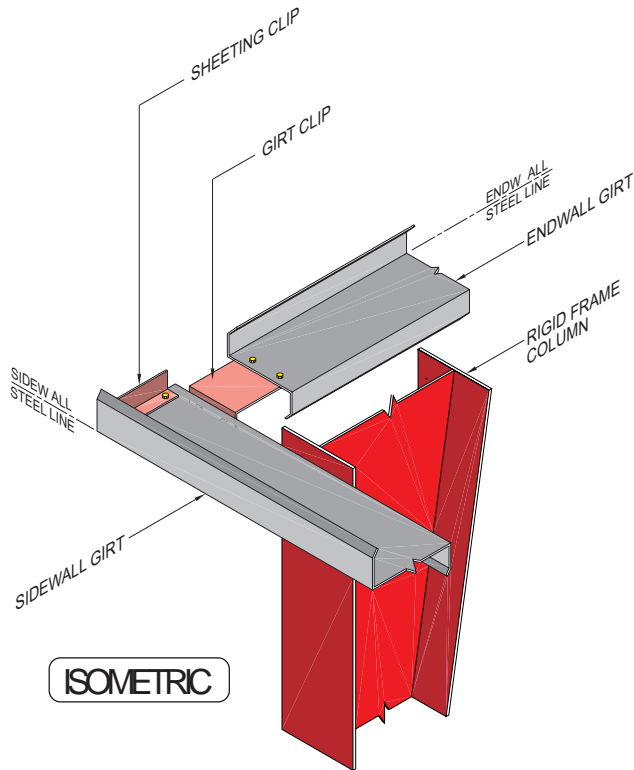

ALL BOLTS ARE M12 x 35 mm A307 BOLTS

**DETAIL -5** : CORNER CONNECTION AT GIRTS OF RIGID FRAME ENDWALL

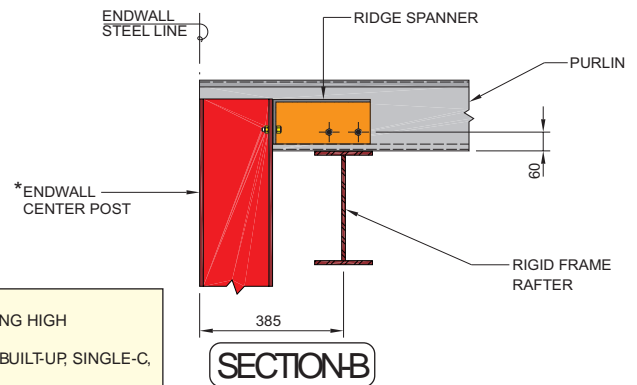
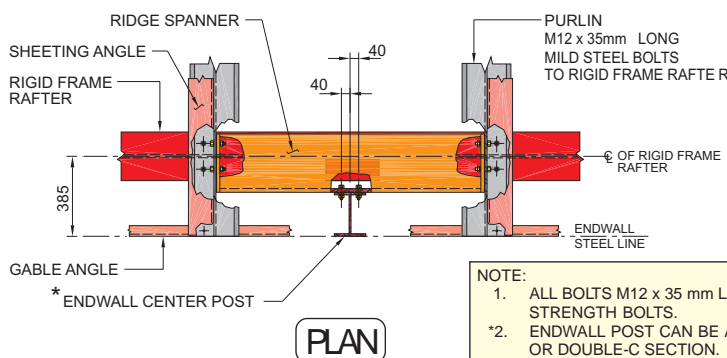
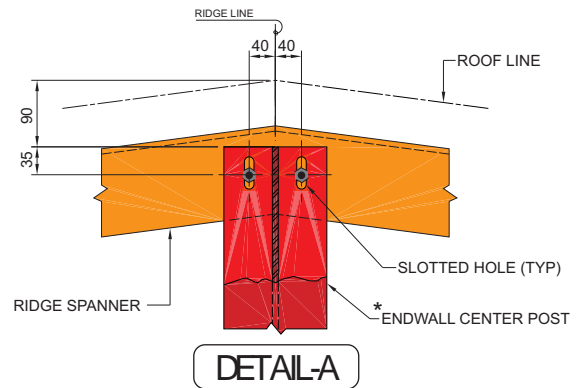
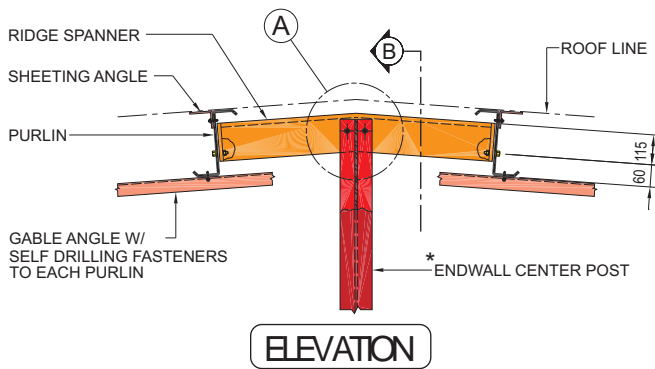

**NOTE:**  
 1. ALL BOLTS M12 x 35 mm LONG HIGH STRENGTH BOLTS.  
 \*2. ENDWALL POST CAN BE A BUILT-UP, SINGLE-C, OR DOUBLE-C SECTION.

**DETAIL -6** : CENTER POST AT RIDGE OF RIGID FRAME ENDWALL

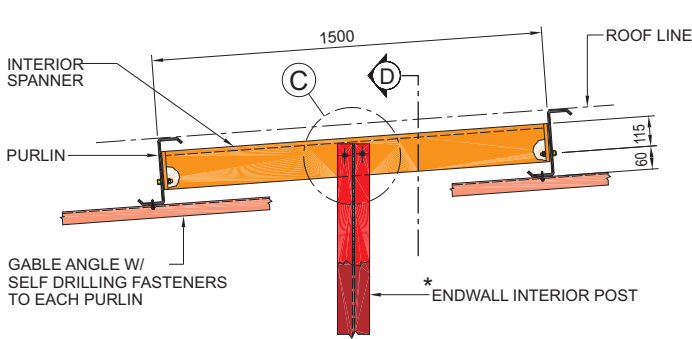

ELEVATION

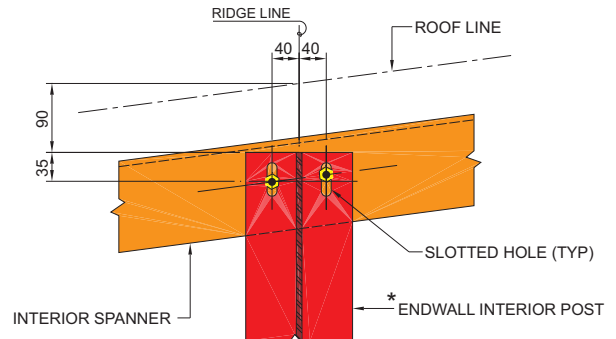

DETAIL-C

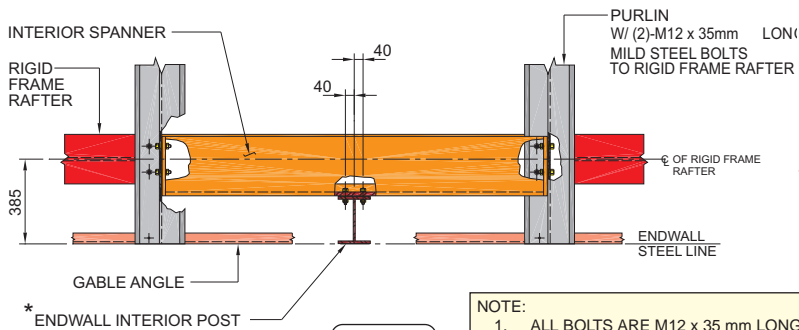

PLAN

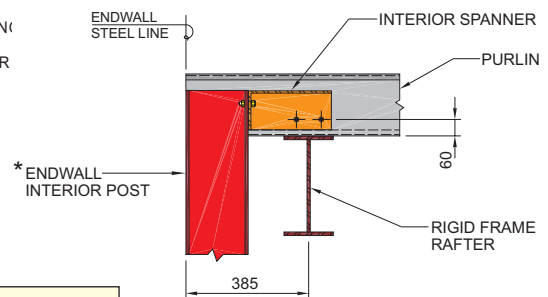

SECTION-D

NOTE:  
1. ALL BOLTS ARE M12 x 35 mm LONG HIGH STRENGTH BOLTS.  
\*2. ENDWALL POST CAN BE A BUILT-UP, SINGLE-C, OR DOUBLE-C SECTION.

DETAIL - 7 : INTERIOR POST AT INTERIOR OF RIGID FRAME ENDWALL

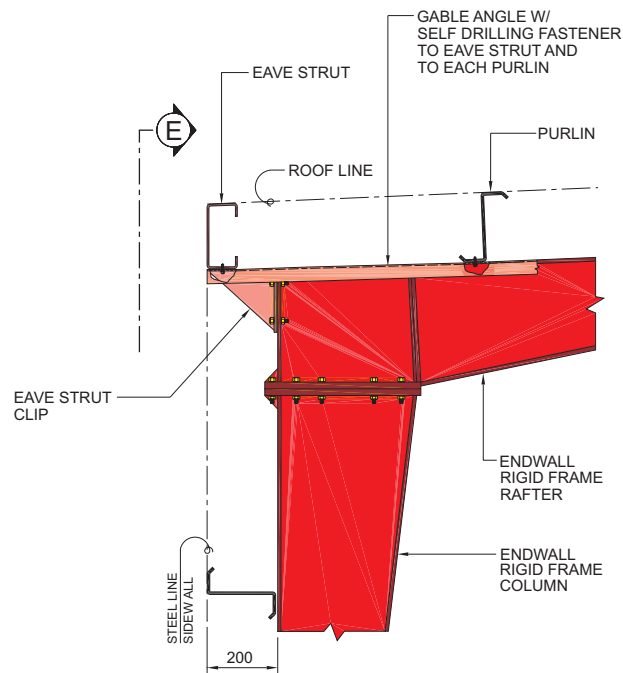

ELEVATION

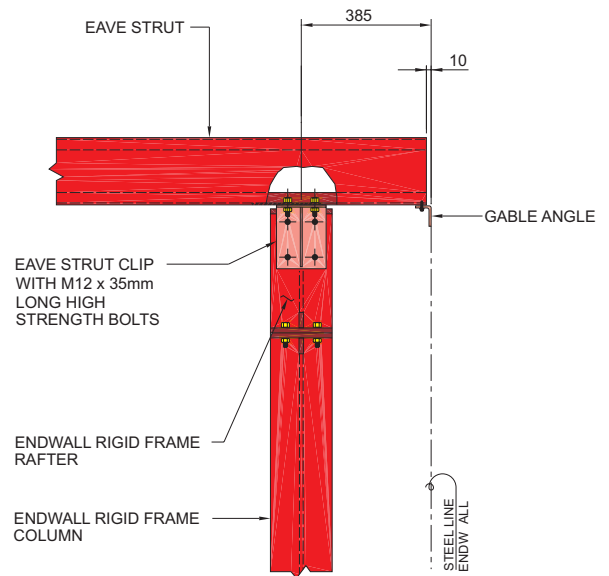

VIEW-E

DETAIL - 8 : CORNER CONNECTION AT EAVE OF RIGID FRAME ENDWALL

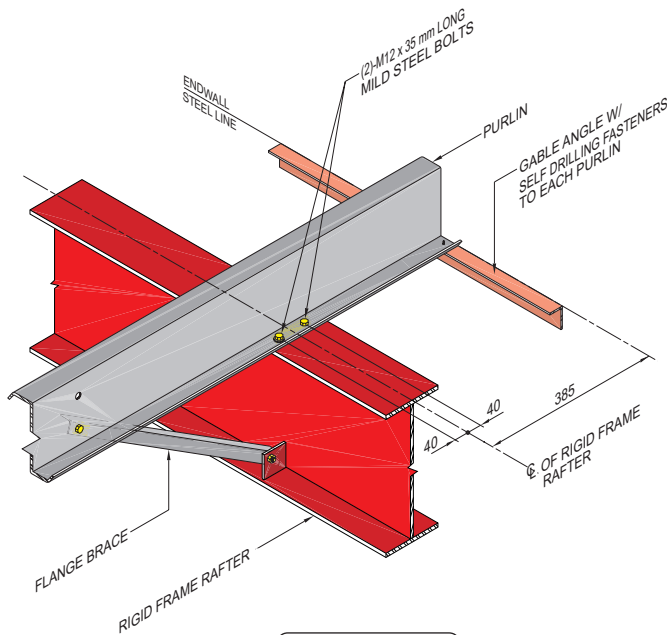

ISOMETRIC

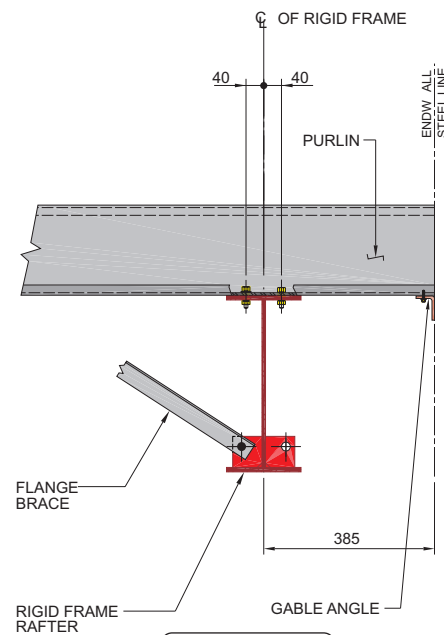

ELEVATION

DETAIL -9 : PURLIN CONNECTION AT RIGID FRAME RAFTER OF RIGID FRAME ENDWALL

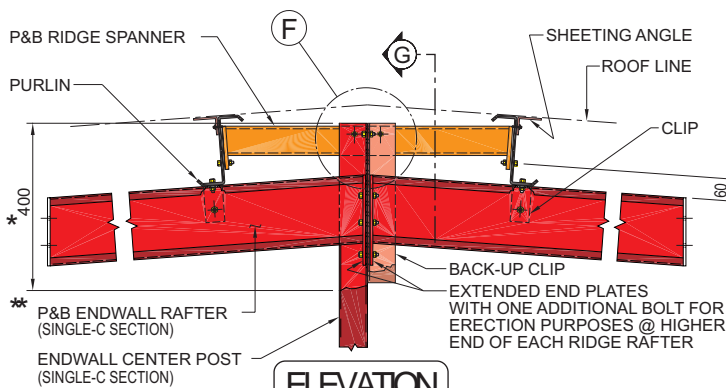

ELEVATION

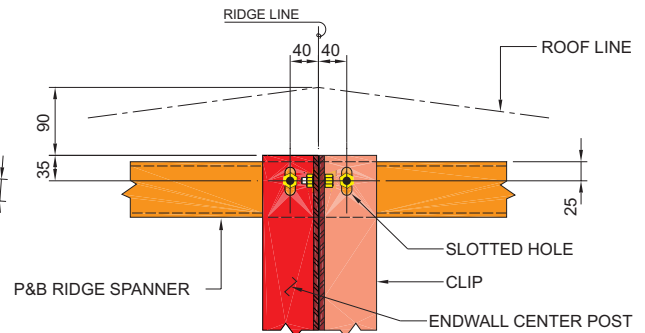

DETAIL-F

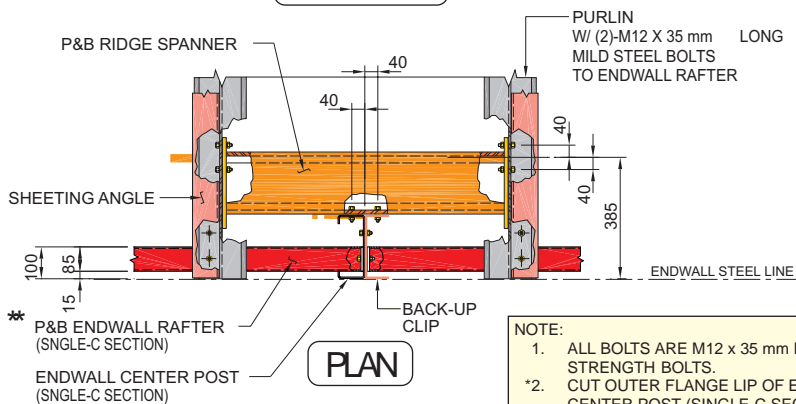

PLAN

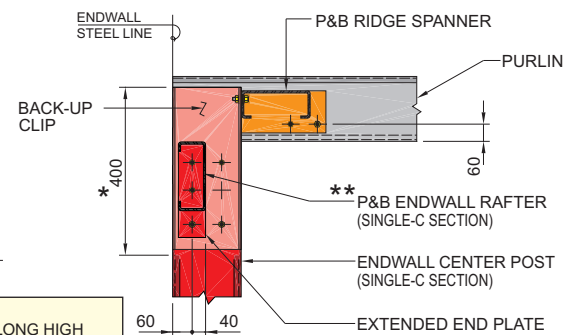

SECTION-G

- NOTE:
1. ALL BOLTS ARE M12 x 35 mm LONG HIGH STRENGTH BOLTS.
  - \*2. CUT OUTER FLANGE LIP OF ENDWALL CENTER POST (SINGLE-C SECTION).
  - \*\*3. ENDWALL RAFTER CAN BE EITHER A SINGLE-C OR DOUBLE-C SECTION.

DETAIL -10 : "SINGLE-C" CENTER POST AT RIDGE OF P & B ENDWALL

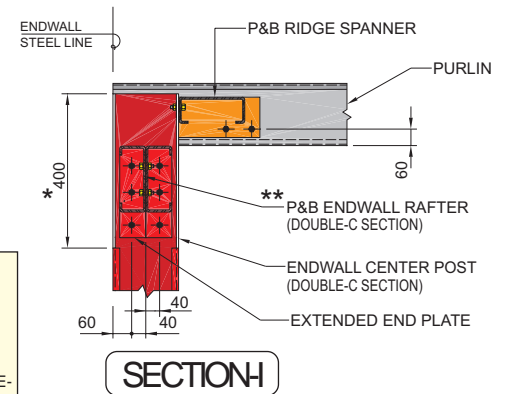
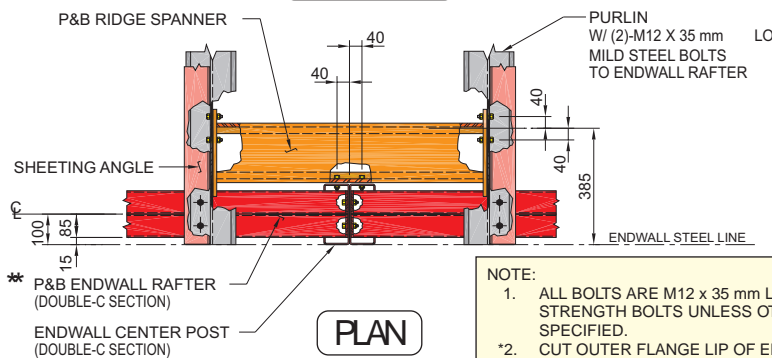
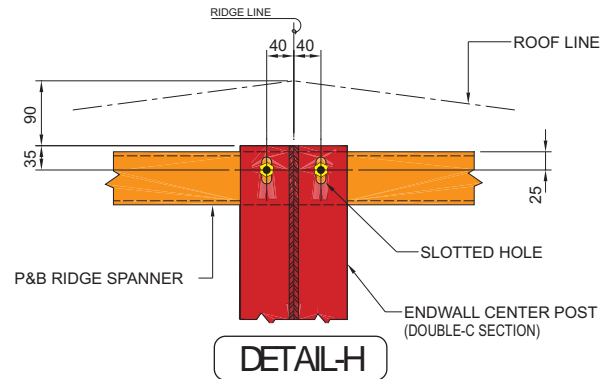
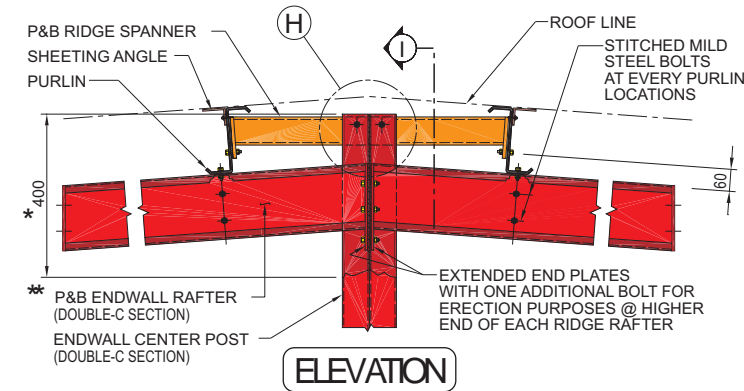

**NOTE:**

1. ALL BOLTS ARE M12 x 35 mm LONG HIGH STRENGTH BOLTS UNLESS OTHERWISE SPECIFIED.
- \*2. CUT OUTER FLANGE LIP OF ENDWALL CENTER POST (DOUBLE-C SECTION).
- \*\*3. ENDWALL RAFTER CAN BE EITHER A DOUBLE-C OR SINGLE-C SECTION.

**DETAIL - 10 : "DOUBLE - C" CENTER POST AT RIDGE OF P & B ENDWALL**

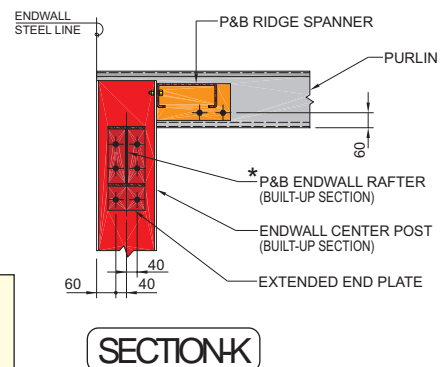
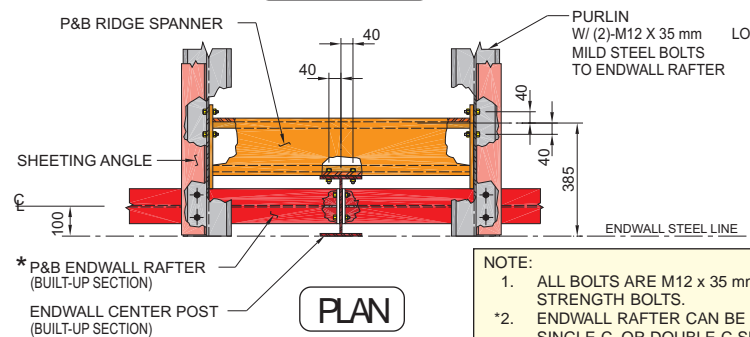
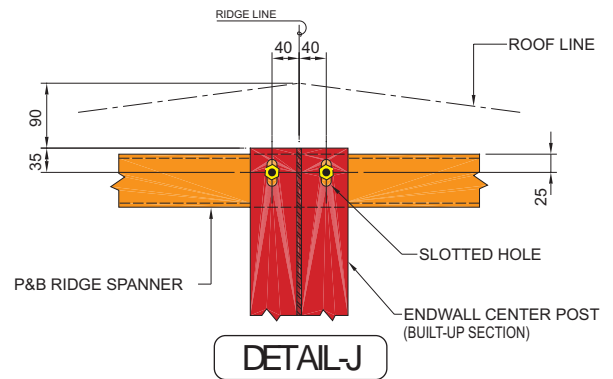
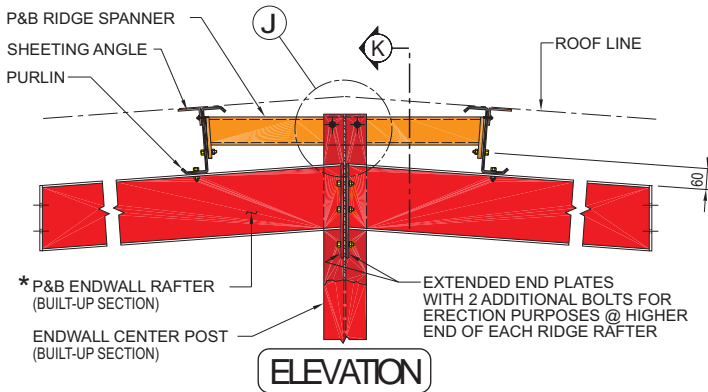

**NOTE:**

1. ALL BOLTS ARE M12 x 35 mm LONG HIGH STRENGTH BOLTS.
- \*2. ENDWALL RAFTER CAN BE A BUILT-UP, SINGLE-C, OR DOUBLE-C SECTION.

**DETAIL - 10 : "BUILT-UP" CENTER POST AT RIDGE OF P & B ENDWALL**



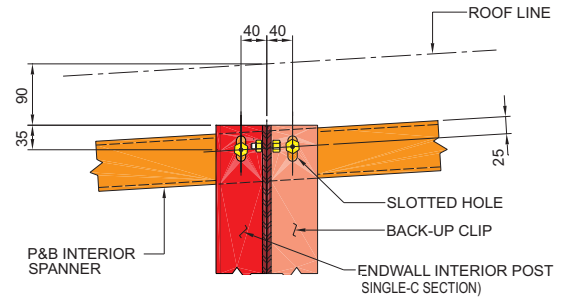
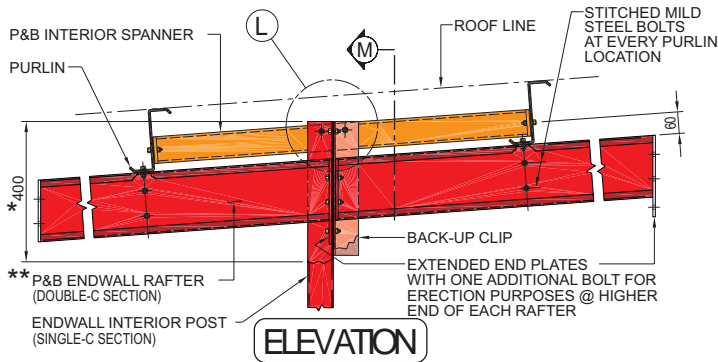

DETAIL-L

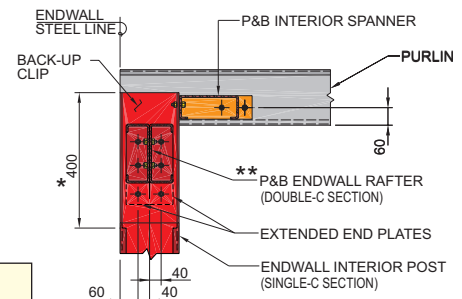
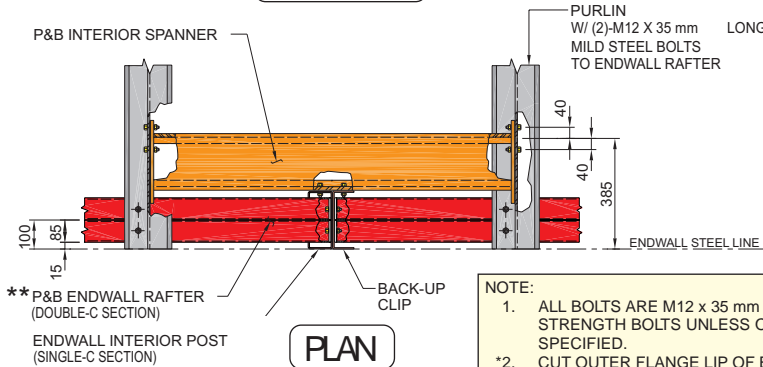

SECTION-M

NOTE:  
 1. ALL BOLTS ARE M12 x 35 mm LONG HIGH STRENGTH BOLTS UNLESS OTHERWISE SPECIFIED.  
 \*2. CUT OUTER FLANGE LIP OF ENDWALL INTERIOR POST (SINGLE-C SECTION).  
 \*\*\*3. ENDWALL RAFTER CAN BE EITHER A DOUBLE-C OR SINGLE-C SECTION.

DETAIL - 11 : "SINGLE - C" INTERIOR POST AT INTERIOR OF P & B ENDWALL

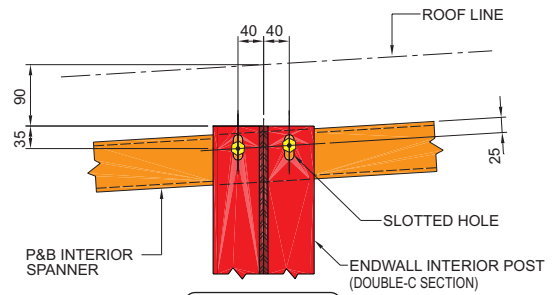
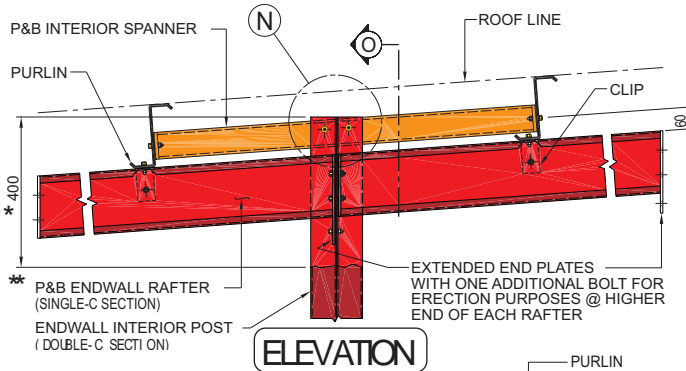

DETAIL-N

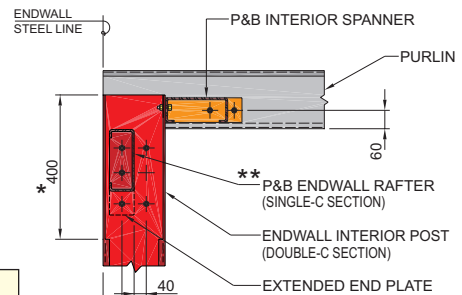
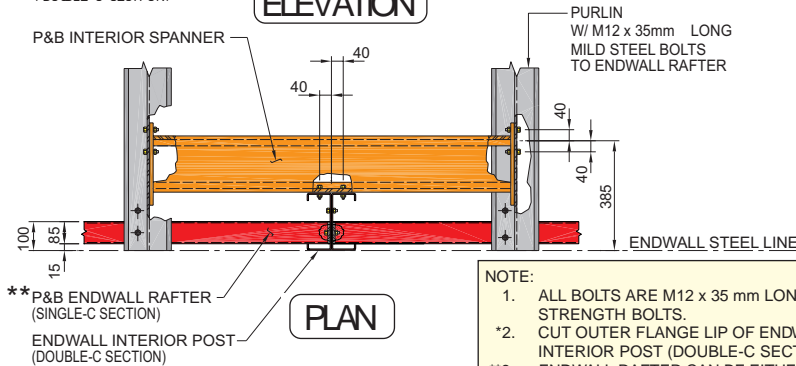

SECTION-O

NOTE:  
 1. ALL BOLTS ARE M12 x 35 mm LONG HIGH STRENGTH BOLTS.  
 \*2. CUT OUTER FLANGE LIP OF ENDWALL INTERIOR POST (DOUBLE-C SECTION).  
 \*\*\*3. ENDWALL RAFTER CAN BE EITHER A DOUBLE-C OR SINGLE-C SECTION.

DETAIL - 11 : "DOUBLE - C" INTERIOR POST AT INTERIOR OF P & B ENDWALL

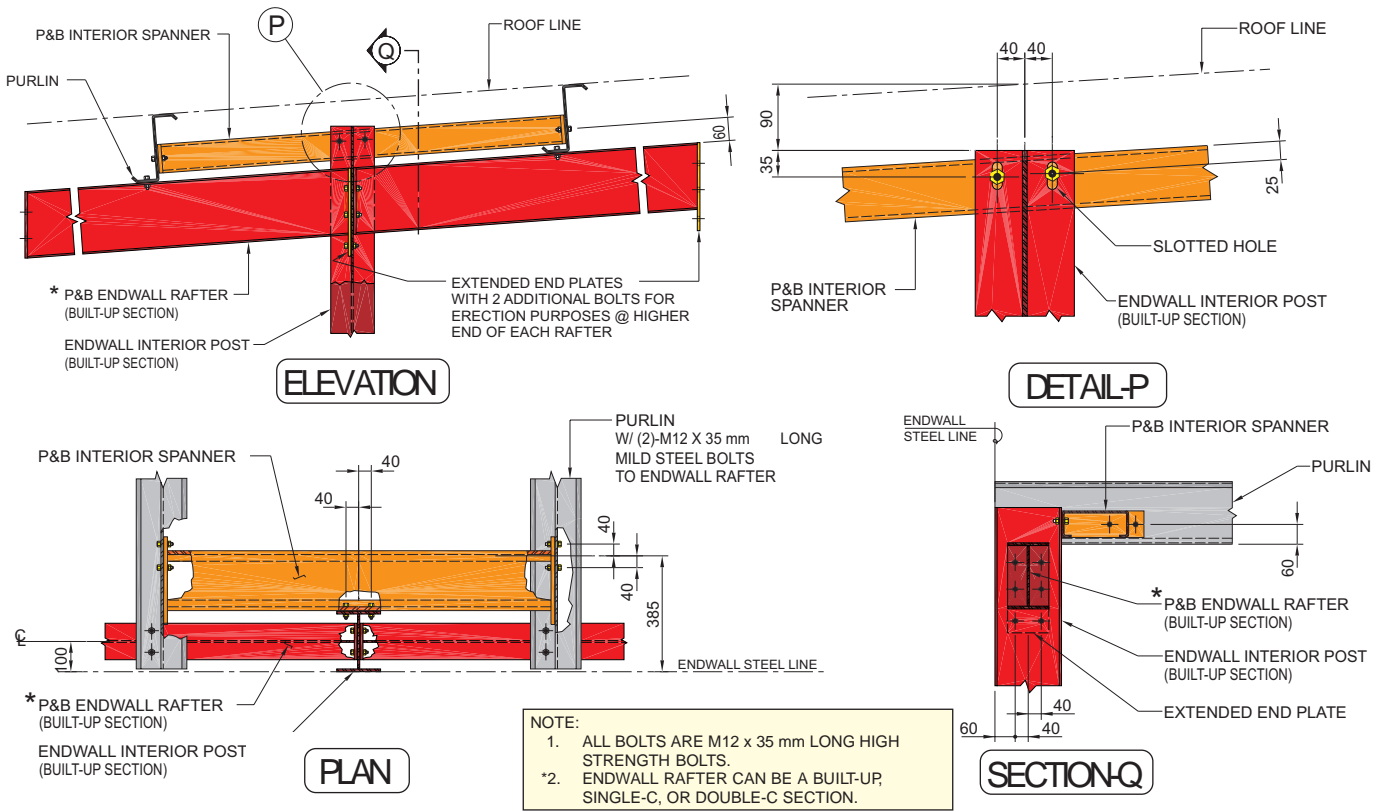

**DETAIL - 11** : "BUILT-UP" INTERIOR POST AT INTERIOR OF P & B ENDWALL

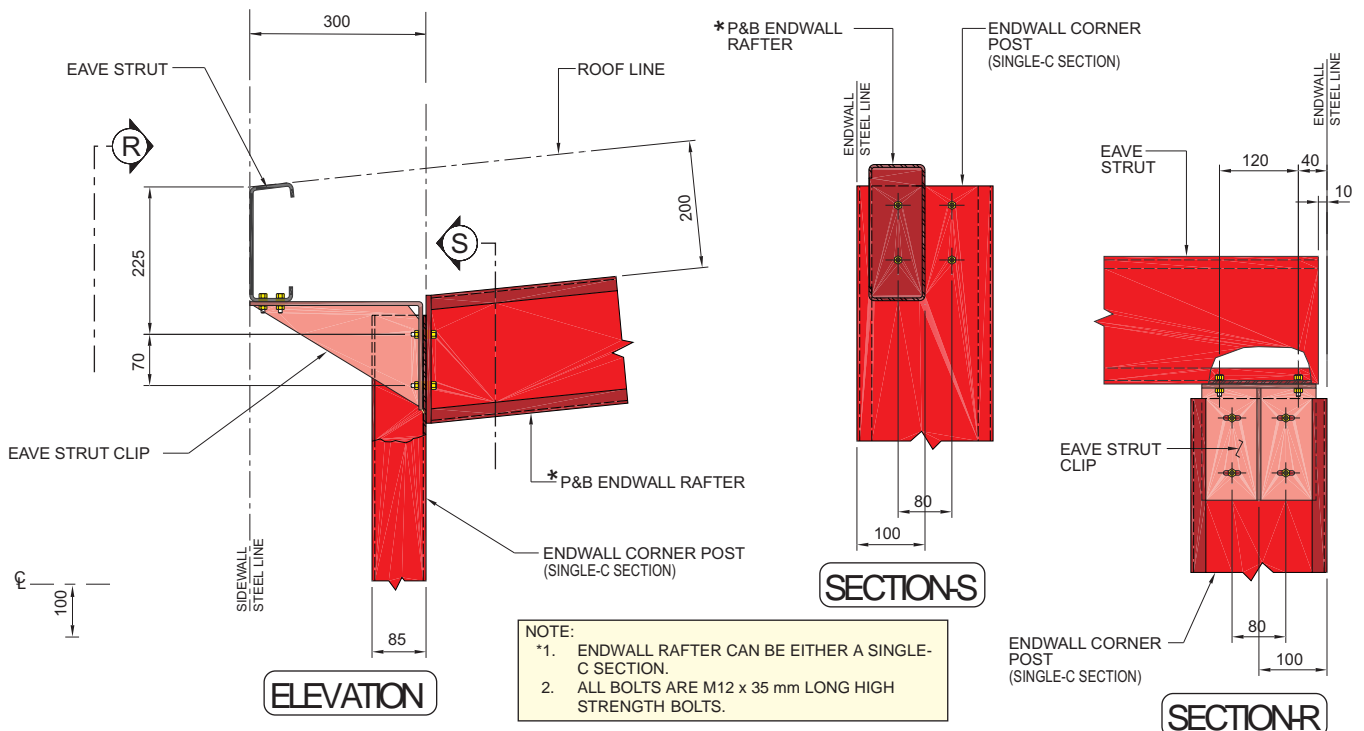

**DETAIL - 12** : "SINGLE-C" CORNER POST AT EAVE OF P & B ENDWALL

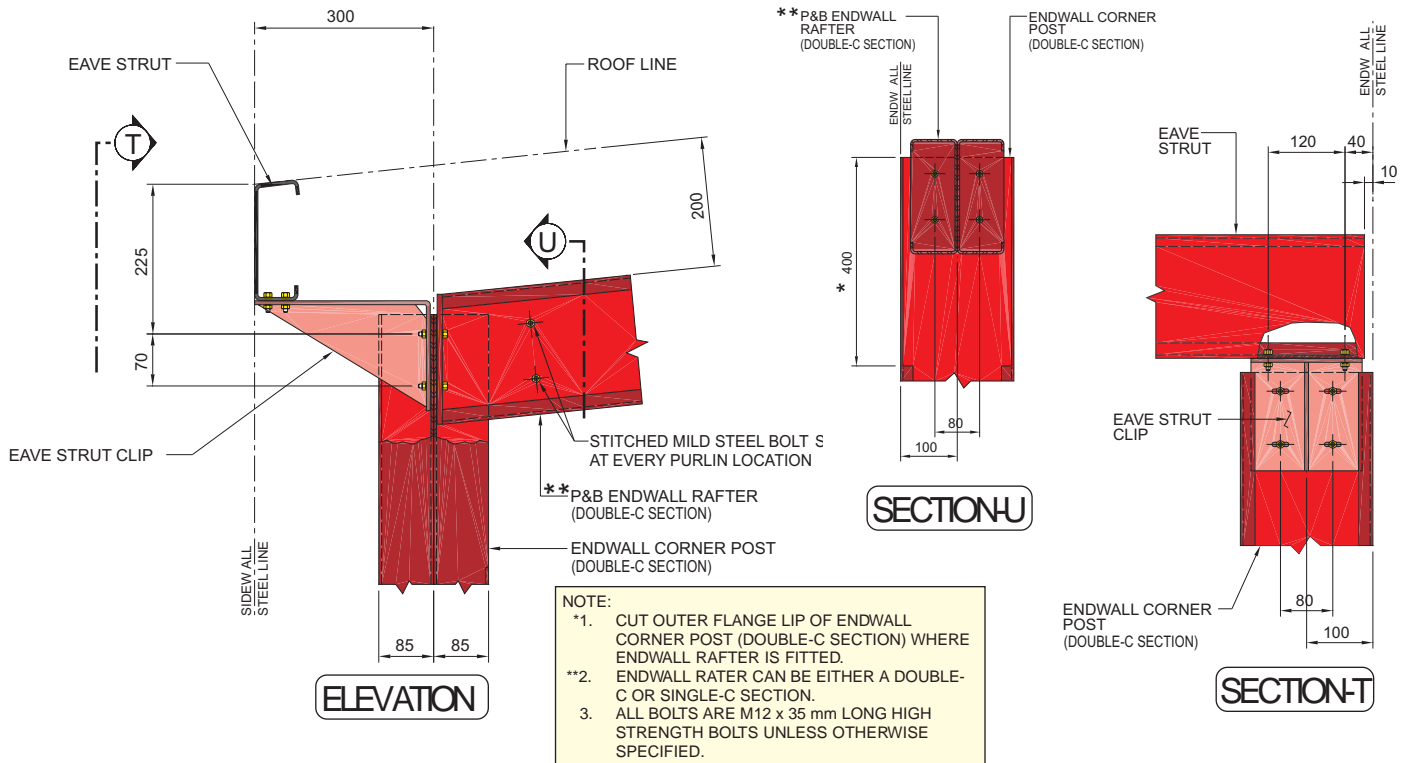

DETAIL – 12 : “DOUBLE-C” CORNER POST AT EAVE OF P & B ENDWALL

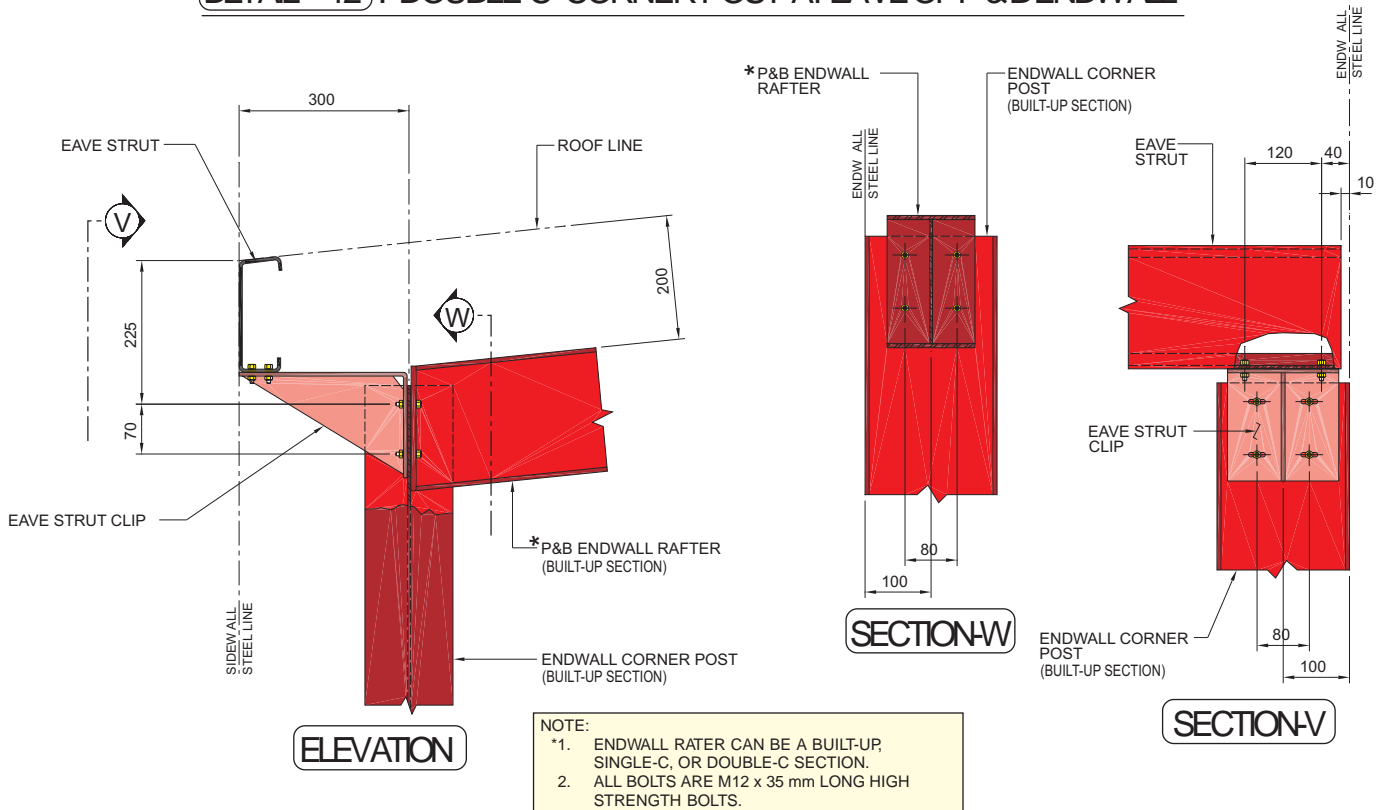

DETAIL – 12 : “BUILT-UP” CORNER POST AT EAVE OF P & B ENDWALL

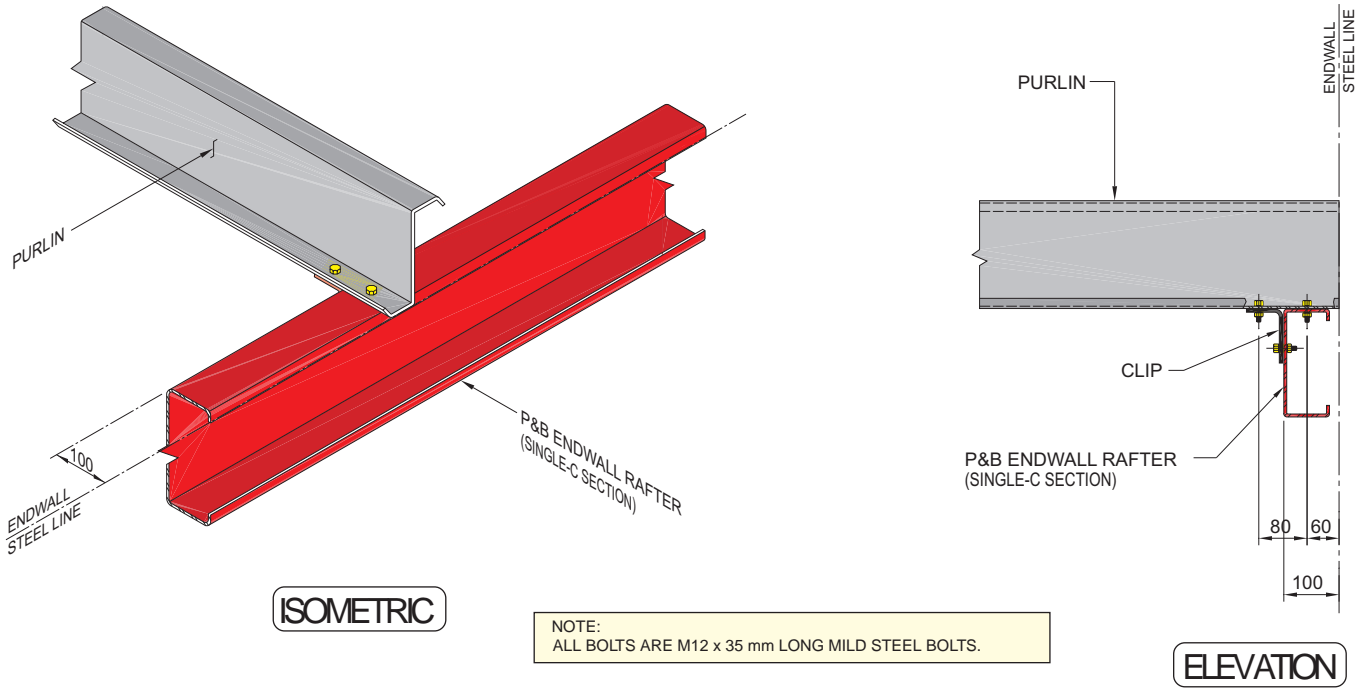

**DETAIL – 13** : PURLIN CONNECTION AT “SINGLE-C” RAFTER OF P & B ENDWALL

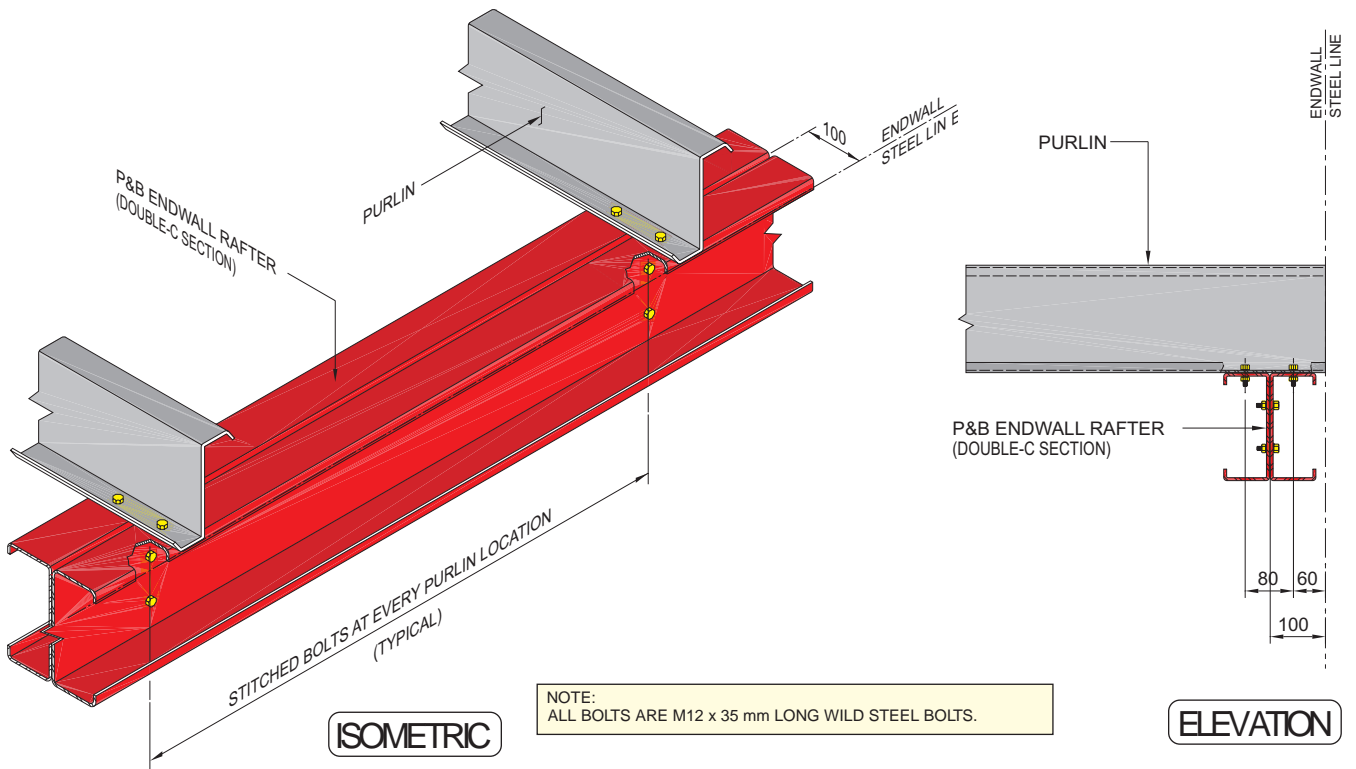

**DETAIL – 13** : PURLIN CONNECTION AT “DOUBLE-C” RAFTER OF P & B ENDWALL

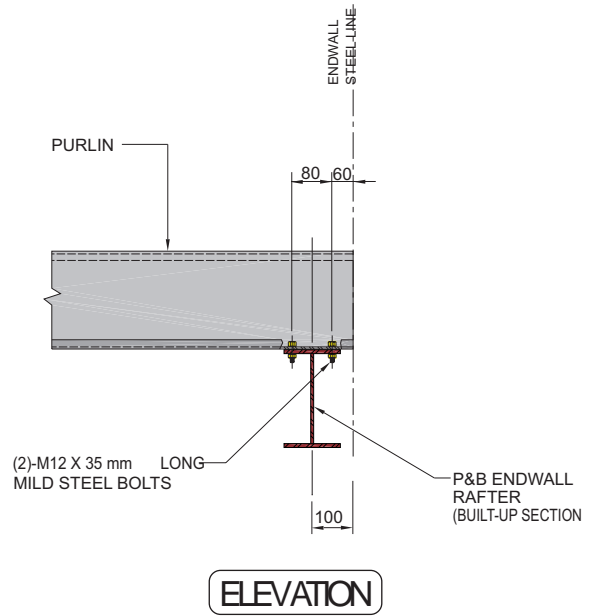
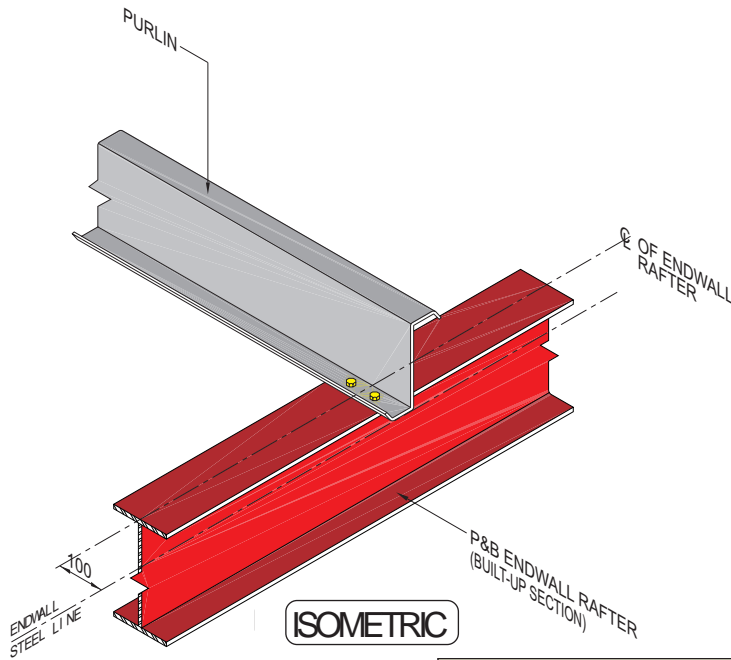

NOTE:  
THE WIDTH OF THE P&B ENDWALL RAFTER (BUILT-UP SECTION)  
SHOWN IN THIS THIS IS EQUAL TO OR ABOVE 130 mm WIDE.

DETAIL – 13 : PURLIN CONNECTION AT “BUILT-UP” RAFTER OF P & B ENDWALL

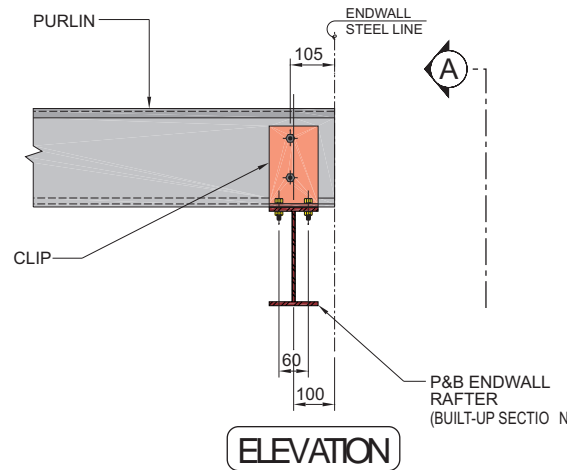
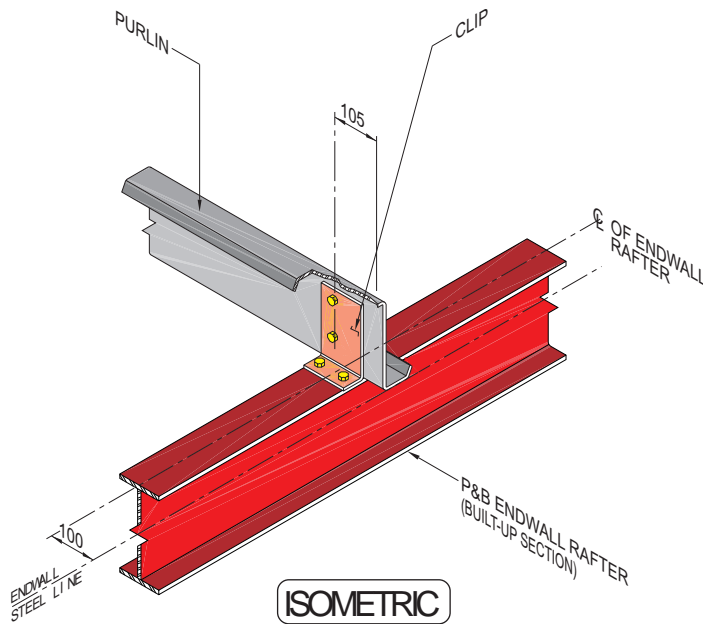

ELEVATION

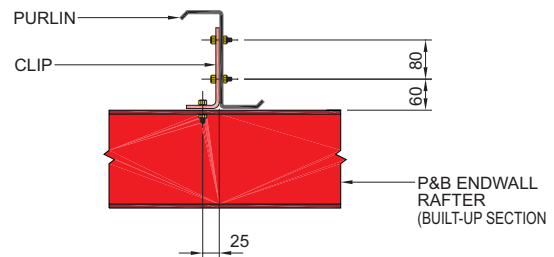

VIEW-A

NOTE:  
THE WIDTH OF THE P&B ENDWALL RAFTER (BUILT-UP SECTION)  
SHOWN IN THIS DETAIL IS LESS THAN 130 mm WIDE.

DETAIL – 13 : PURLIN CONNECTION AT “BUILT-UP” RAFTER OF P & B ENDWALL

A **jack beam** is a horizontal structural member. It normally spans between two alternate frames in order to support the roof rafter of the intermediate frame at a column location when that column has to be removed to provide clear space at the finished floor level.

Within exterior walls, jack beams are required when a bay longer than 10 m is desired along the length of a building. This is sometimes necessary when a long bay is specified due to frequent movement of large equipment or trailers that load and unload materials inside a factory or a warehouse. The use of jack beams allows bay lengths of up to 20 m.

In the interior, jack beams are encountered at the top of interior columns of Multi-Span buildings when one or more of the interior columns must be removed to provide clear space at the finished floor level.

Zamil Steel jack beams can be straight or tapered built-up sections and are designed to support vertical and horizontal loads when used in exterior sidewall applications, and vertical loads only when used in interior Multi-Span applications.



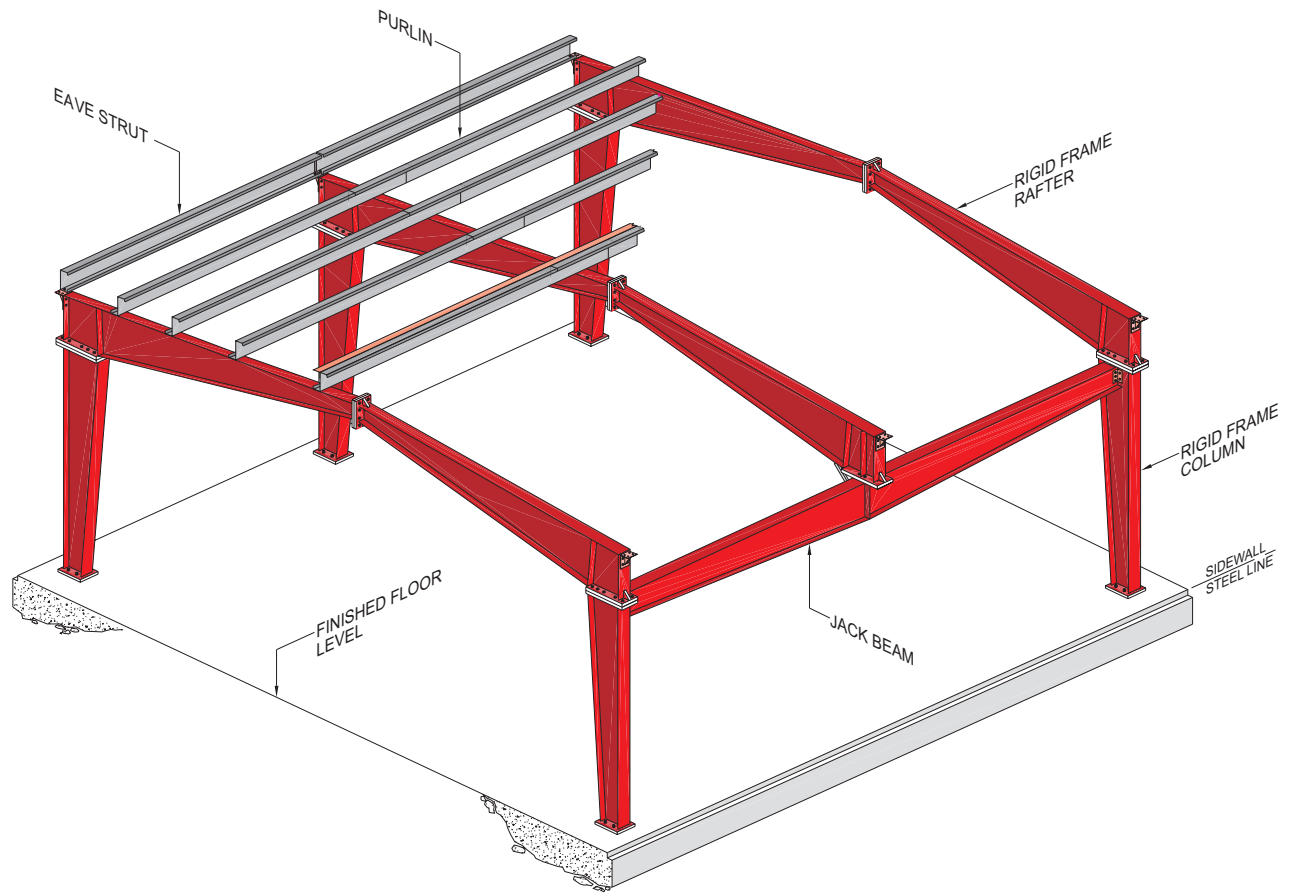

**ISOMETRIC** : JACK BEAM AT SIDEWALL

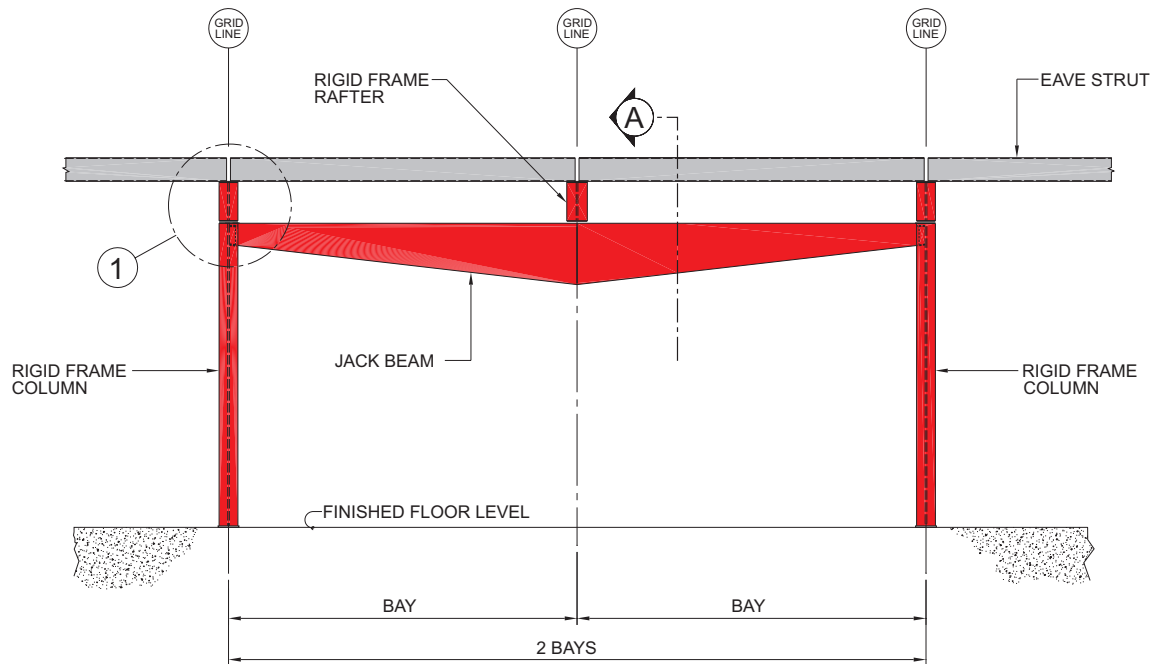

**ELEVATION** : JACK BEAM AT SIDEWALL

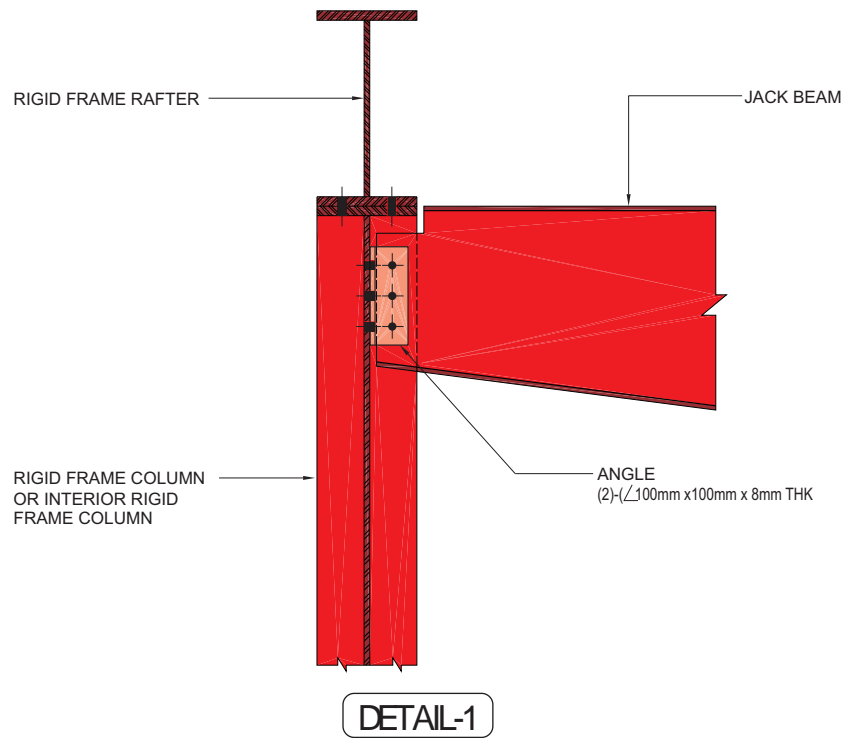
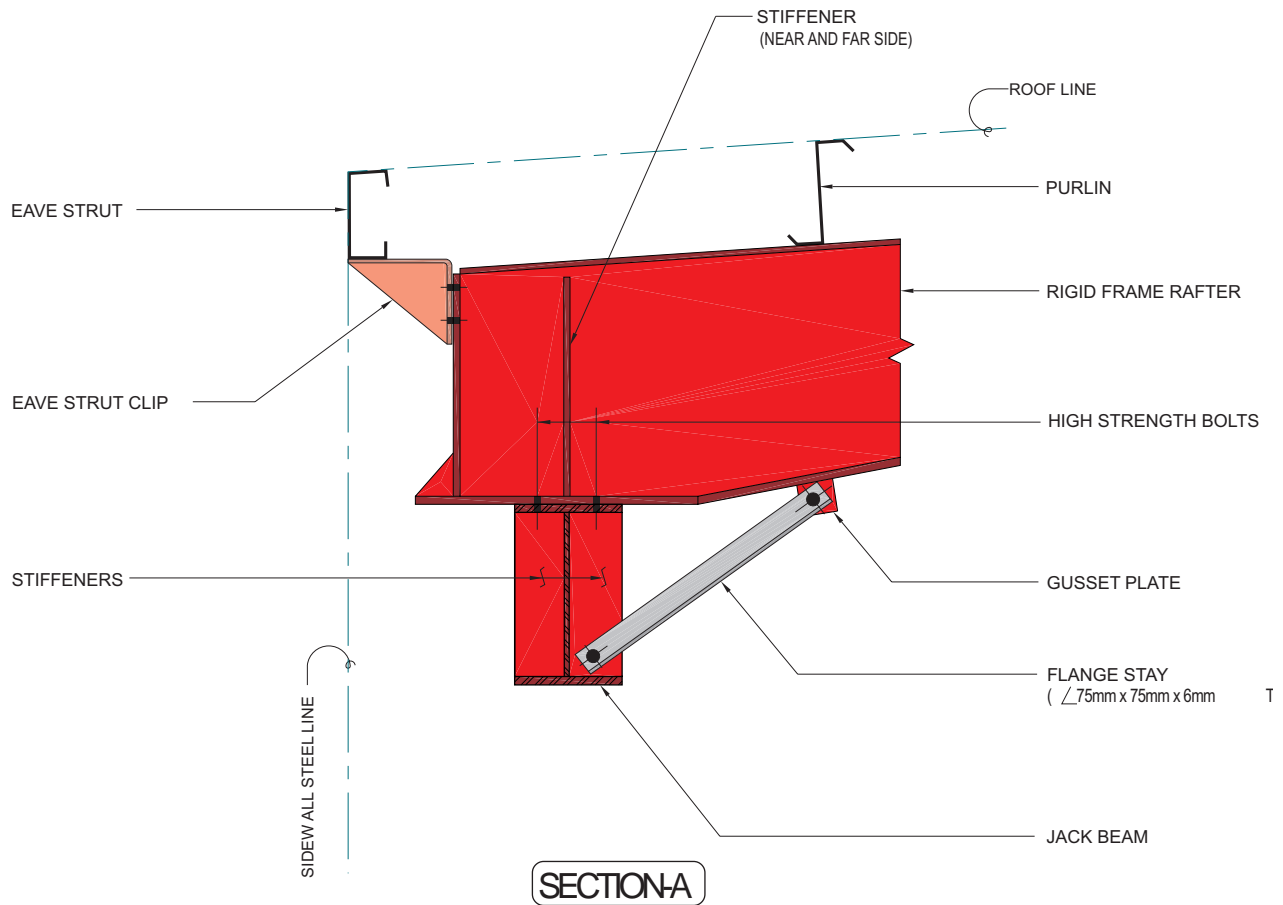



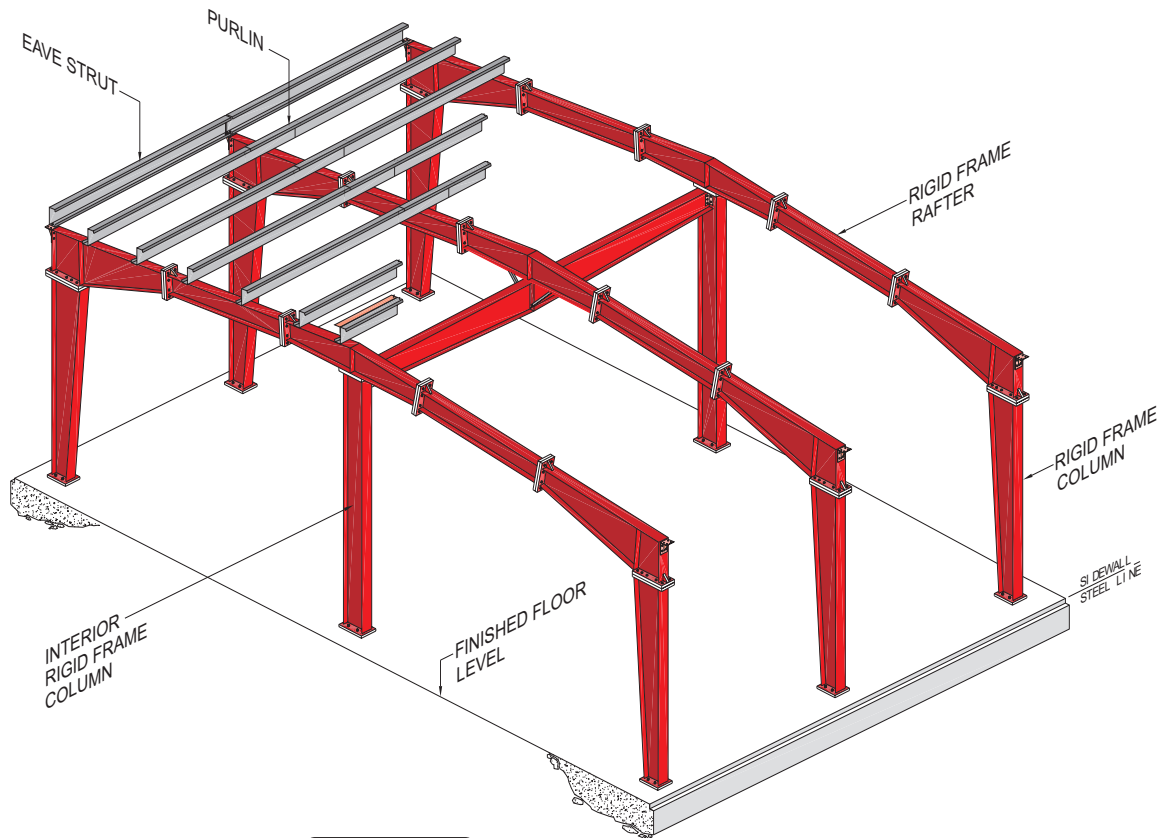

ISOMETRIC : INTERIOR JACK BEAM

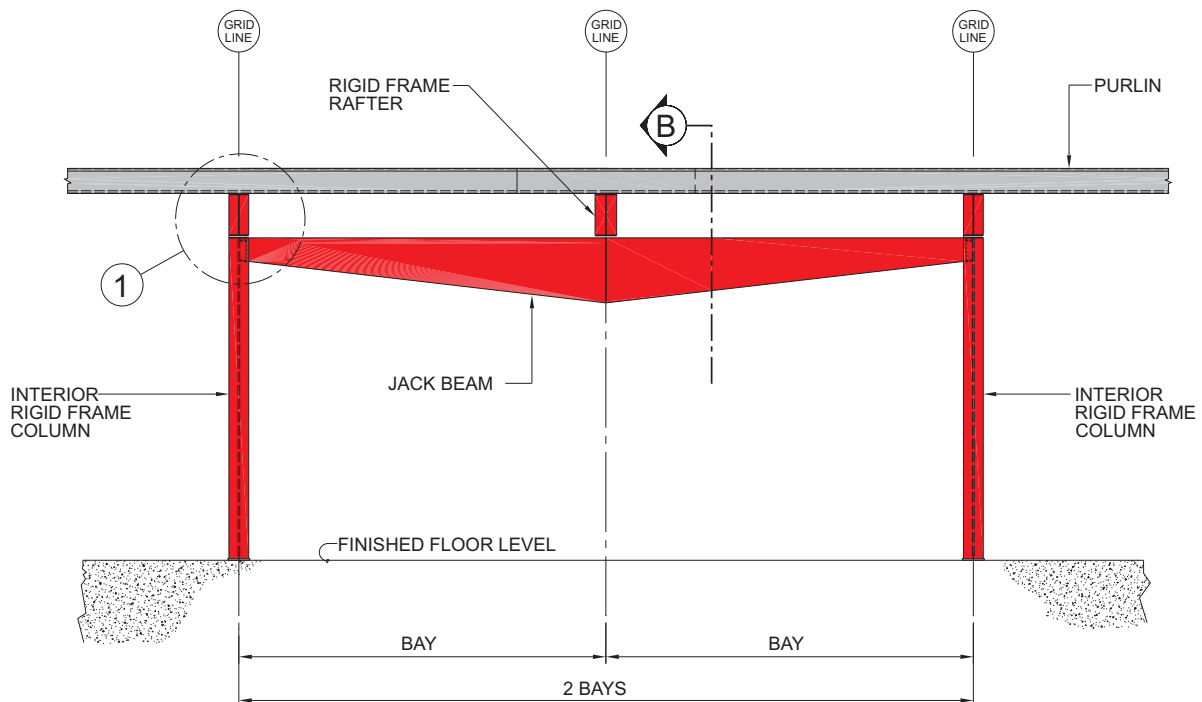

ELEVATION : INTERIOR JACK BEAM

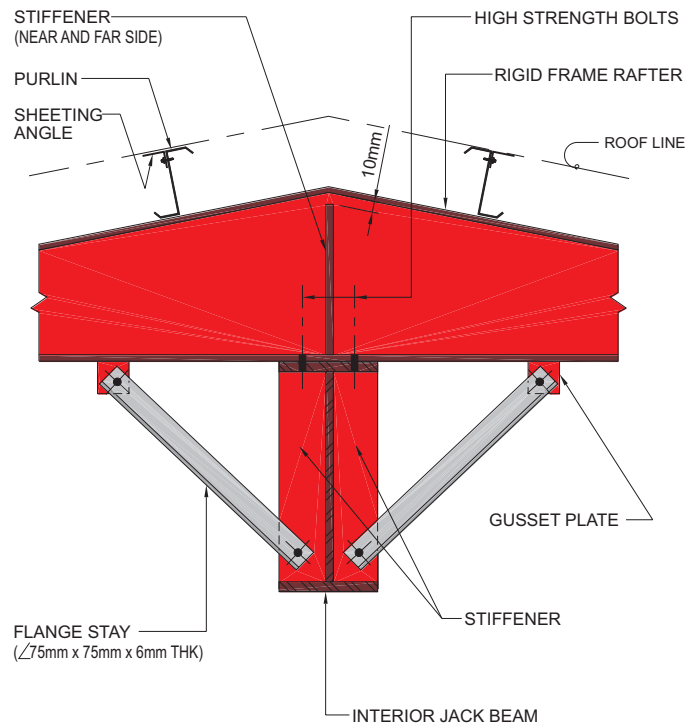

**ISOMETRIC** : JACK BEAM AT MIDDLE OF RAFTER

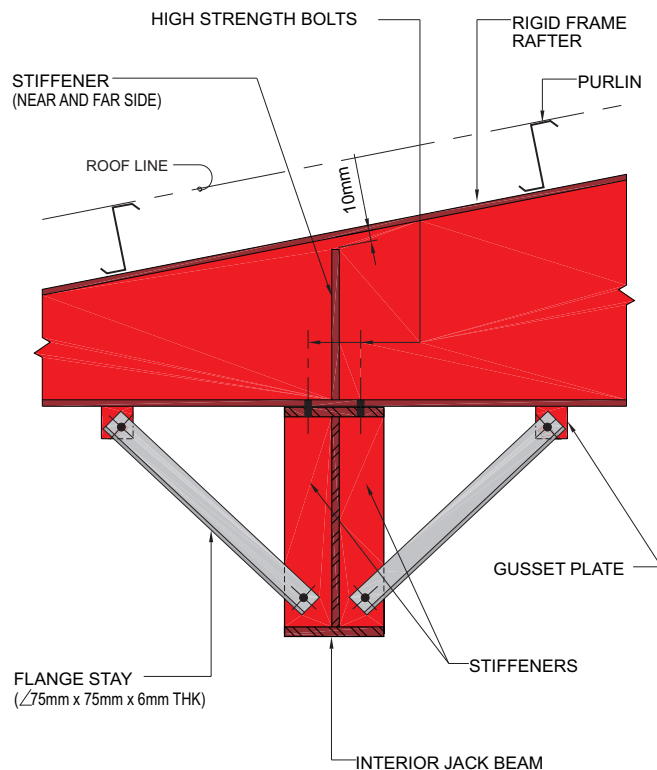

**ELEVATION** : JACK BEAM AT INTERMEDIATE SPAN OF RAFTER

Materials expand when heated and contract when cooled. The amount of expansion or contraction depends on the type of the material and its molecular structure.

The coefficient of linear thermal expansion is a measure of the incremental increase in the length of a member per unit length resulting from a single unit increase ( $^{\circ}\text{C}$  or  $^{\circ}\text{F}$ ) in temperature.

When a member is restrained from free movement during expansion or contraction, stresses develop in the member. These thermally induced stresses may be *compressive* or *tensile* depending on whether the restrained member is undergoing expansion or contraction. If these additional stresses are not considered in the design of that member, failure may occur. Thus, **expansion joints** are provided at certain intervals along a member to absorb accumulated incremental movements resulting from temperature changes during the life of the structure.

In steel construction proven guidelines exist for calculating the required distance between expansion joints and for determining the type of fastener slots that must be provided to insure that the structure can expand and contract freely.

A safe but very expensive practice for releasing longitudinal thermal stress requires the provision of double rigid frames at expansion joint locations. We believe that this is unnecessary unless there is a requirement for a fire wall at the longitudinal expansion joint location.

Zamil Steel's standard practice for releasing excessive longitudinal thermal stresses is to use only one rigid frame at the location where an expansion joint is required and to provide slotted purlin holes at the location of the expansion joint that can absorb thermal movements at that point.

The following table shows the temperature variations during the year in different locations of Saudi Arabia.

Location	Temperature Variation ( $^{\circ}\text{K}$ )
Jeddah	20.0
Jizan	20.0
Alwajh	25.0
Yanbu	25.0
Dammam	30.0
Madina	30.0
Najran	30.0
Khamis Mushait	35.0
Riyadh	35.0
Taif	40.0
Tabouk	40.0
Hail	40.0

The maximum building length allowed before an expansion joint is needed to resist **longitudinal expansion** can be calculated from the following formula:

$$L = \frac{24 \times N}{[(0.0921 \times K \times \Delta T) - 1]} \quad \text{where,}$$

L = Maximum building length, m

N = Number of bays

$\Delta T$  = Temperature variation, °K

K = 1.00 for buildings without air conditioning

= 0.70 for buildings with air conditioning

= 0.55 for buildings with heating and air conditioning

The above formula is based on a maximum allowable stress of 2.5 kN/cm<sup>2</sup> on the purlins due to thermal expansion.

However, it is recommended to provide an expansion joint whenever the building length exceeds 120 m even if the above formula results in a longer allowable length.

**Lateral expansion** for buildings due to thermal loads is normally considered in the design of a frame only when the frame width exceeds 100 m.

**Example:**

A 117 m long building located in Riyadh, Saudi Arabia, is made of 13 equal (9 m) bay lengths. The building is not air-conditioned. Is there a need for an expansion joint?

From the table on page 1 of 5 of this **section** ( $\Delta T$  in Riyadh = 35½ K.

The building is not air conditioned so K = 1.00

$$\begin{aligned} L &= \frac{24 \times 13}{[(0.0921 \times 1.0 \times 35) - 1]} \\ &= 140.0 \text{ m} > 117.0 \text{ m} \end{aligned}$$

There is no need to provide an expansion joint in the building.



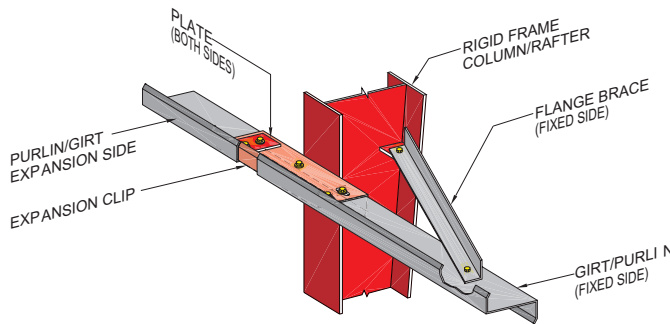

**ISOMETRIC**

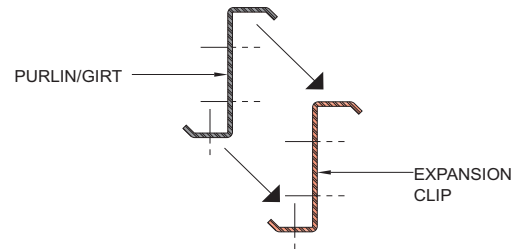

**IMPORTANT:**  
PURLIN / GIRT SHOULD REST OVER EXPANSION CLIP AS SHOWN ABOVE.

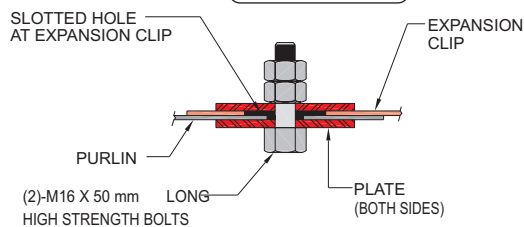

**SECTION-A**

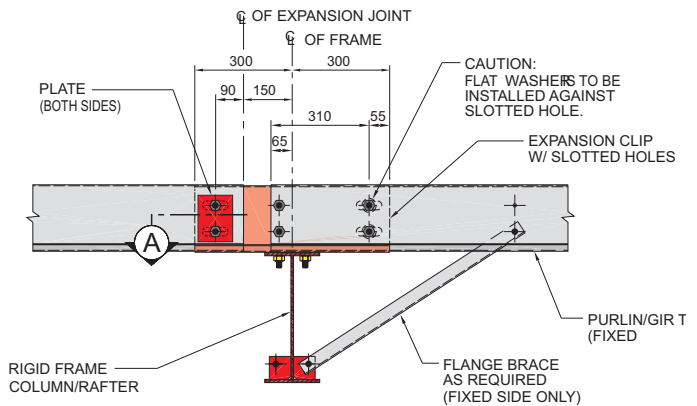

**PLAN** : PURLINGIRT CONNECTION AT EXPANSION JOINT

**NOTE:**  
1. HAND TIGHTEN NUTS, THEN TIGHTEN INNER NUT AGAINST OUTER NUT WITH WRENCH TO ALLOW MOVEMENT OF STRUCTURAL MEMBERS.  
2. ALL BOLTS ARE M12 x 35 mm LONG MSB UNLESS OTHERWISE NOTED.

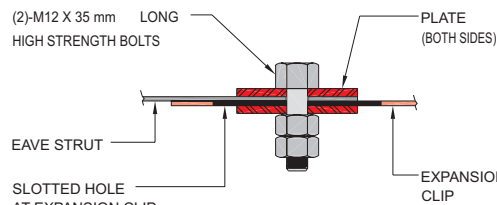

**DETAIL-1**

**NOTE:**  
1. HAND TIGHTEN NUTS, THEN TIGHTEN INNER NUT AGAINST OUTER NUT WITH WRENCH TO ALLOW MOVEMENT OF STRUCTURAL MEMBERS.  
2. ALL BOLTS ARE M12 x 35 mm LONG MSB UNLESS OTHERWISE NOTED.

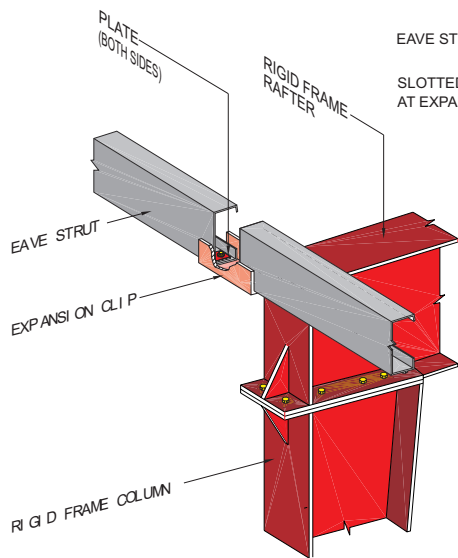

**ISOMETRIC**

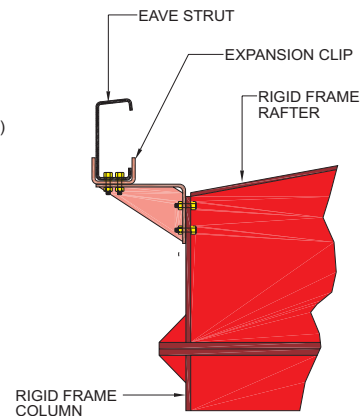
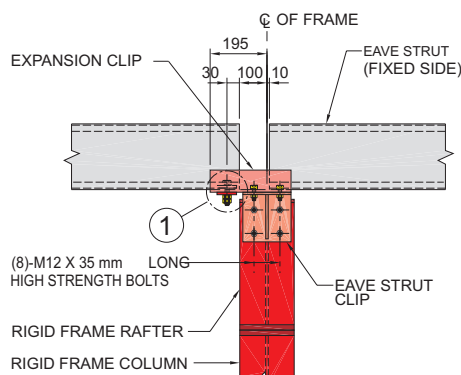

**ELEVATION** : EAVE STRUT CONNECTION AT EXPANSION JOINT

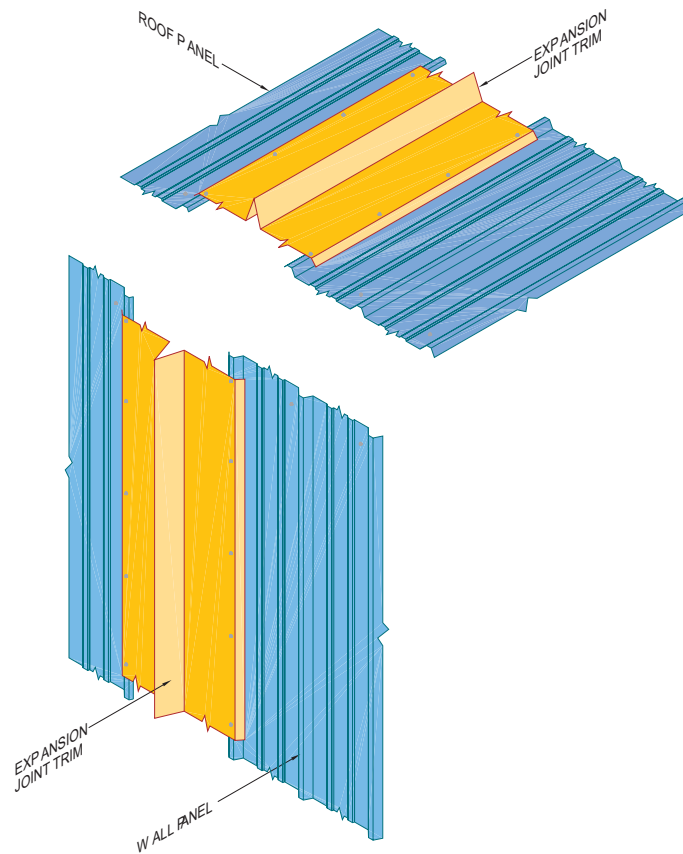

**ISOMETRIC** : ROOF AND WALL PANELS AT EXPANSION JOINT

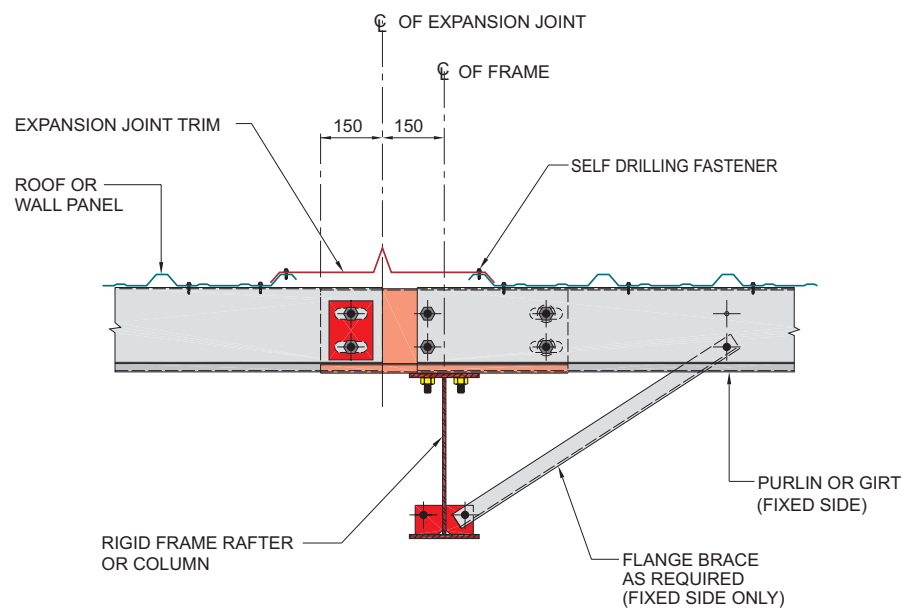

**SECTION** : PANEL CONNECTION AT EXPANSION JOINT

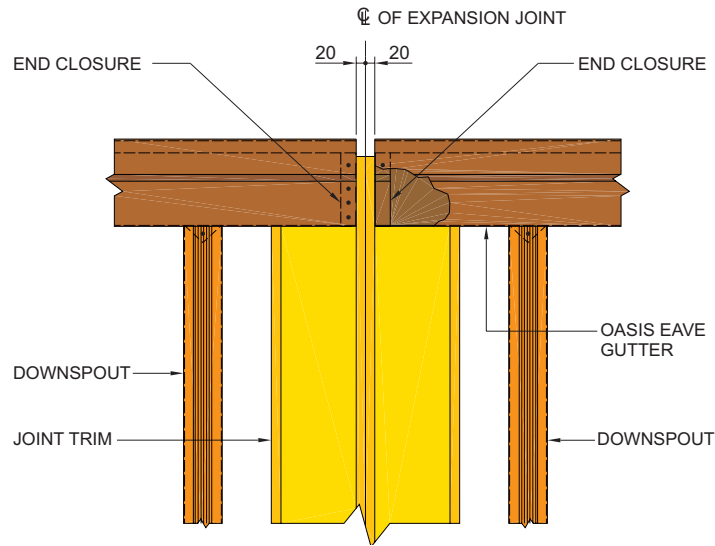

**DETAIL : GUTTER AT EXPANSION JOINT**

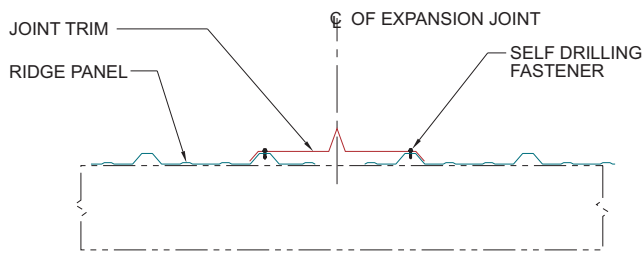

**SECTION-X**

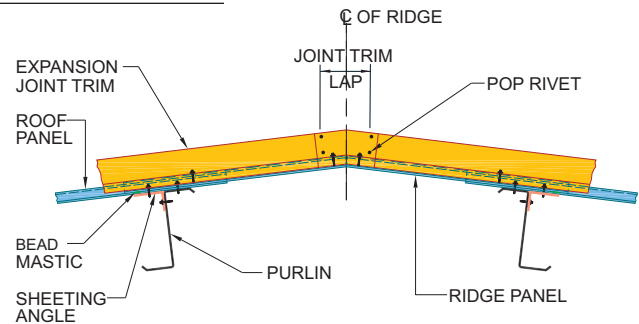

**SECTION-Y**

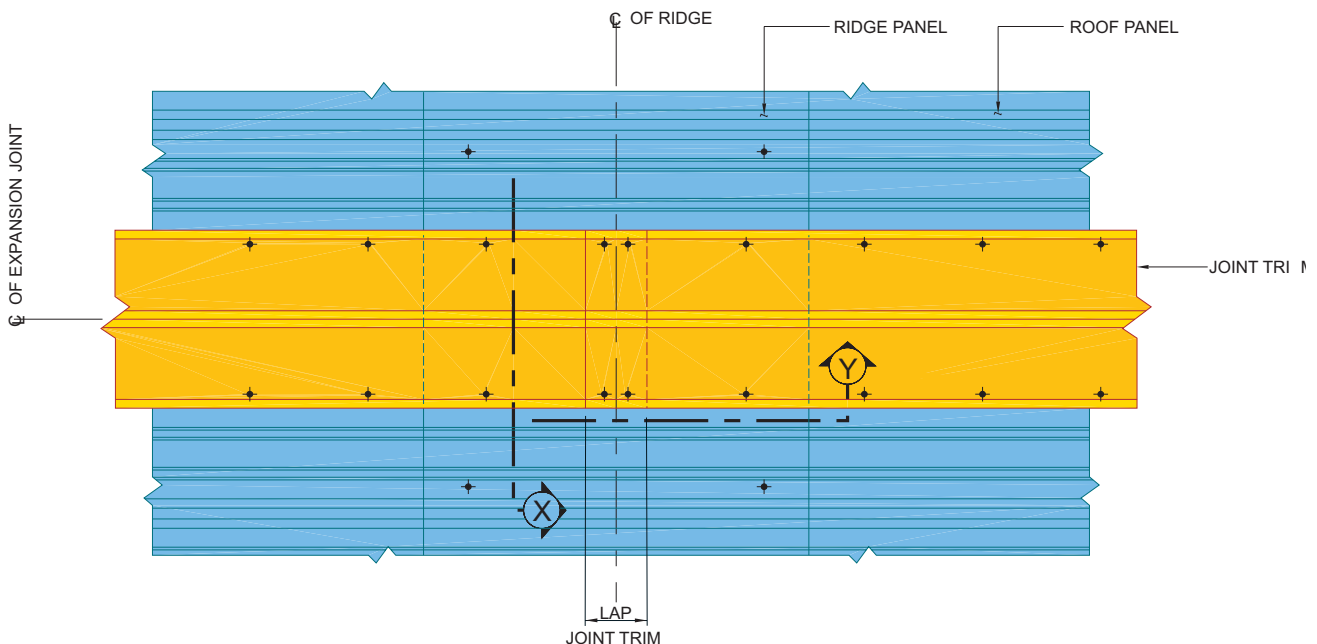

**DETAIL : EXPANSION JOINT AT RIDGE**

As a normal practice the walls of a Zamil Steel building are sheeted with pre-painted Zinalume panels available in a range of standard colors. Pre-painted panels are economical, attractive and easy to install.

However, in some applications, clients find it necessary to specify a partial height or full height masonry wall or blockwall. The most common reasons for choosing a blockwall are when:

- Storage inside the building might be placed against the exterior walls of the building.
- Stored material, if in contact with wall panels, might initiate or encourage steel corrosion.
- Heavy forklift activity outside the building may accidentally dent the metal walls.
- There is a desire to buy locally made accessories (personnel doors, louvers, windows, etc.) that are designed primarily for blockwalls.
- A blockwall is needed for architectural reasons.

Although the provision for a blockwall or a masonry wall is an option, Zamil Steel has developed many standard details for buildings with masonry walls or a combination of masonry and sheeted walls.

When an endwall is open (unsheeted) for blockwall, up to a certain elevation, Zamil Steel requires that the endwall posts be tied to the blockwall at standard girt locations, or at a maximum spacing of 2 meters, along the full height of the blockwall, in order to maintain adequate bracing of the endwall posts.

When this situation occurs in sidewalls, Zamil Steel's practice is to design the columns for a free standing condition (unbraced) up to the full height of the blockwall.

Foam closures, trims and flashing are provided at the transition between the wall sheeting and the

masonry wall in order to provide a watertight joint and a neat finished appearance.

When considering the partial removal of the metal wall sheeting, it is important to know the standard location of wall girts so that an economically sound decision can be made. The location of the first wall girt is at 2.25 meters above the finished floor level and this is the most economical height for blockwalls in a standard Zamil Steel pre-engineered building.





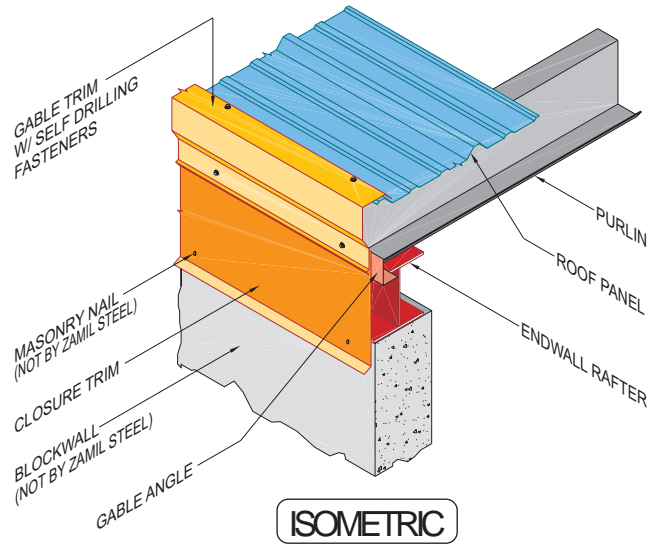
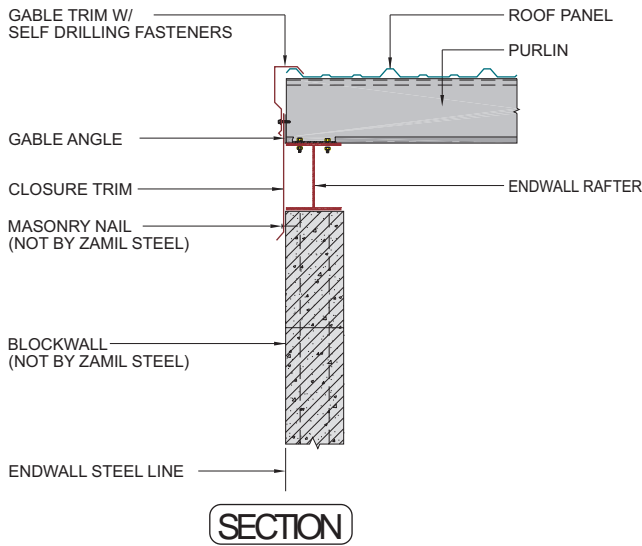

DETAIL : BLOCKWORKS AT GABLE

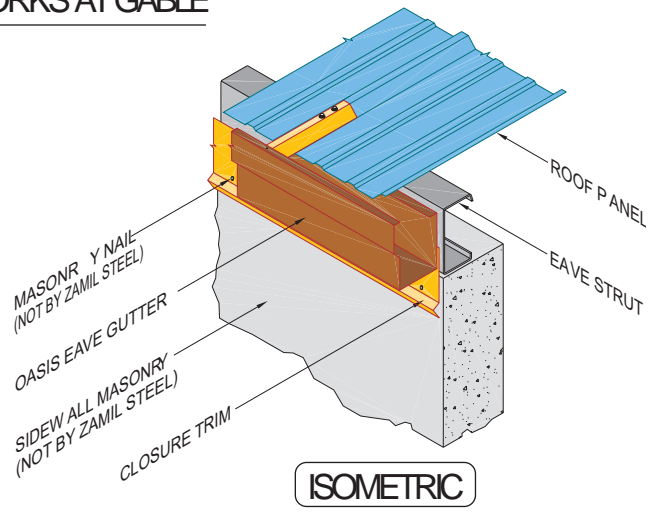
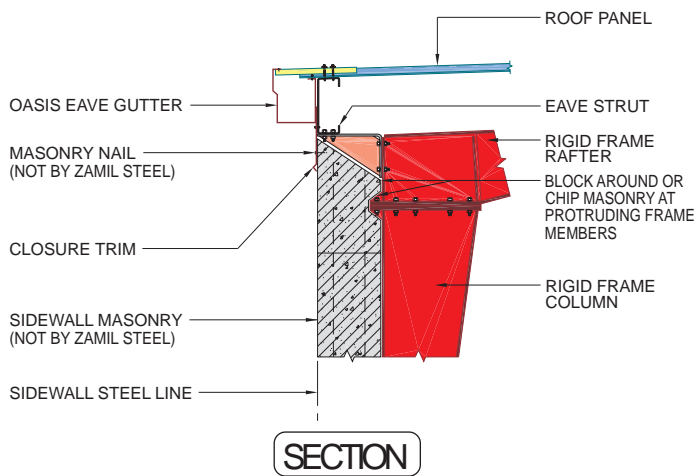

DETAIL : BLOCKWORKS AT EAVE

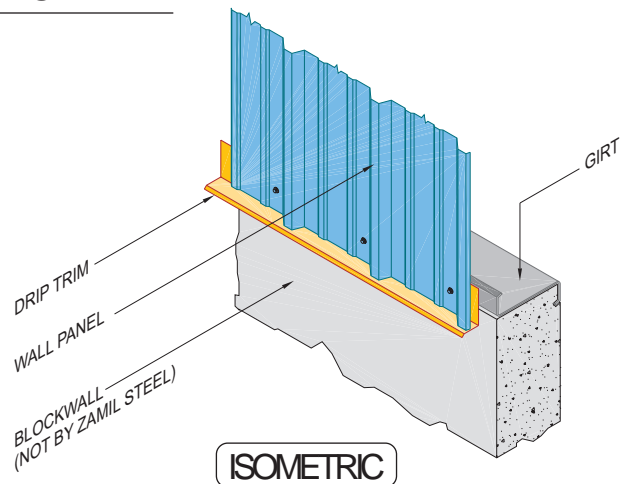
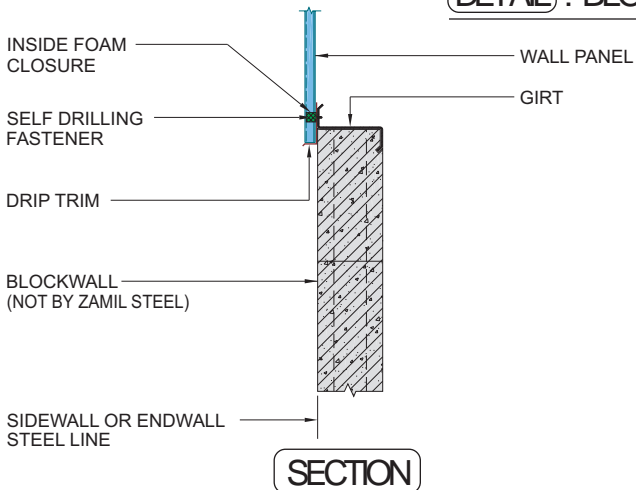

DETAIL : BLOCKWORKS AT GIRTS

Precast concrete panels are one of the numerous types of wall systems that can be easily integrated and are very frequently used with pre-engineered steel buildings. Zamil Steel does not supply precast panels, however, many standard details for precast concrete walls or a combination of precast concrete walls and sheeted walls have been developed.

Even though precast concrete panels are more expensive than cast in-situ concrete and concrete block, they offer several advantages:

- Precast panels can be sized, shaped and textured to suit the architectural requirements of the buildings.
- Installation of the precast panels is faster and easier.
- Precast panels are prepared in controlled environments versus cast in-situ concrete that requires extensive on site supervision and inspection.
- Lengthy casting and curing times on-site are not

required since, precast panels are produced off-site.

Precast panels are self-supported on the ground. Horizontal structural members are supplied by Zamil Steel on the wall to provide lateral stability. Zamil Steel also supplies special brackets to support precast panel fascias.

In order to accommodate the precast wall system in the design and detailing of the pre-engineered steel building, clear sketches should be submitted to Zamil Steel, at the quotation stage. The sketches should clearly illustrate the exact dimensions of the precast panels and the details of the fixing points.

It is also important to provide Zamil Steel with the name of precast concrete supplier and his project manager in-charge, in order to obtain other details related to their precast system such as loading conditions, fixing system, etc.

For further information consult any Zamil Steel representative.



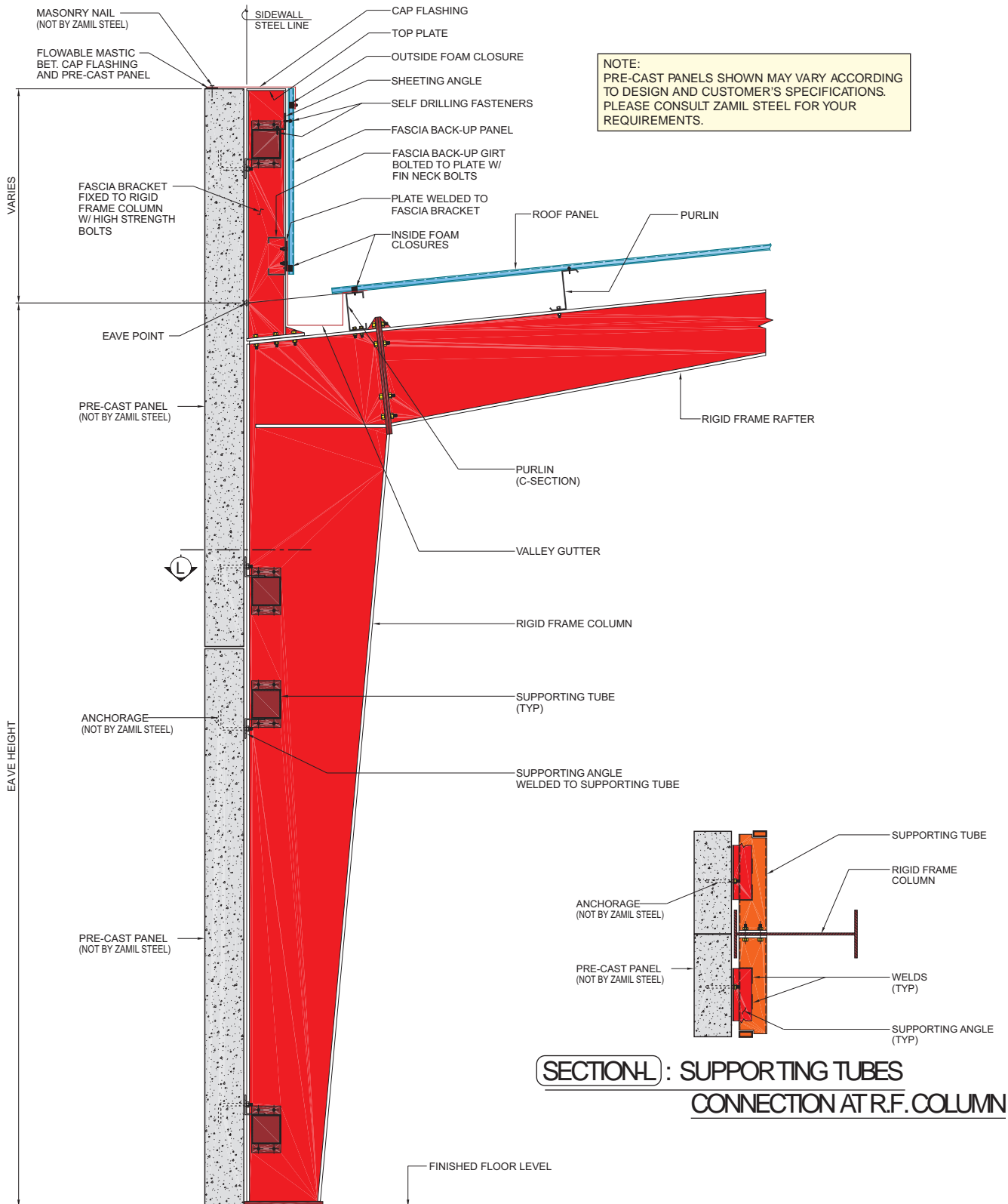

**SECTION L : SUPPORTING TUBES CONNECTION AT R.F. COLUMN**

**ELEVATION : PRE-CAST PANELS AT SIDEWALL**



# **SINGLE SKIN PANELS**

## 8. Single Skin Panels

8.1	General .....	151
8.2	Steel Panels .....	152
8.3	Steel Panel Paint Systems .....	154
8.4	Steel Panel Coating Tests .....	165
8.5	Steel Panels Properties & Load Tables .....	168
8.6	Aluminium Panels .....	176
8.7	Aluminium Panels Properties & Load Tables .....	177
8.8	Exterior Roof and Wall Panel Details .....	182
8.9	Interior Roof and Wall Liner Details .....	186



The term “**panel**” in this context refers to the metal skins used as roof and wall panels, interior roof and wall liners, partition panels, soffit panels, etc. Zamil Steel offers a variety of profiles, base metals, metal substrates and coatings for its panels.

Zamil Steel offers eight different panel profiles, each is suitable for one or more application in the building. Please refer to the publication “Zamil Steel’s Panel Chart (colors & profiles)” for the most current availability of panel colors and thicknesses.

Zamil Steel stocks two different base metals for the panels: **steel and aluminum**.

Zamil Steel panel offering can be summarized in the following table:

Base Metal	Specification Substrate	Metal	Paint Systems	Profile Type
Steel	ASTM A792 Grade 50B (or equivalent)	Zincalume	Plain	A,B,C D,E,F G & R
			XRW	
			XPD	
			Powder Coating	
		Galvanized	XSE	
Aluminum	ASTM B209 Alloy 3003 H26	Not applicable	Plain	
			Environ	
			Powder Coating	

More details about Zamil Steel panels and their properties are discussed further in this section.

Zamil Steel has developed its range of offering of steel panels to suit different applications, environment exposures and loading conditions.

### Exterior Face Finish Coating

Zamil Steel offers three types of exterior face finish coatings for its steel panels. The term “exterior” refers to the exposed face of the metal panel, i.e. the visible face. The nominal film thickness of the finish coating system is 1 mil (25 microns). For the complete specifications of these 3 coatings refer to **section 8.3** of this manual. The 3 finish coats are:

1. “**XRW**” : The term “XRW” is an abbreviation for *exterior roofing and walling*. It is a modified polyester polymer coating and is the standard offering of Zamil Steel. It is stocked in the following :

Nominal Skin Thickness (mm)	Color
0.5	Bare Zinalume. All Zamil Steel standard colors.
0.6	Bare Zinalume, Frost White.
0.7	Bare Zinalume, Frost White.

Other skin thicknesses and colors are available upon request and may be subject to extended delivery. Consult an authorized Zamil Steel representative for prices & delivery.

2. “**XPD**” : The term “XPD” is an abbreviation for *exterior premium durability*. This is the well-known polyvinyl fluoride coating (PVF2, PVDF, etc.) equivalent to Kynar 500. It is stocked in the following:

Nominal Skin Thickness (mm)	Color
0.5	Frost White
0.6	Frost White
0.7	Frost White

Other skin thicknesses and colors are available upon request and may be subject to extended delivery. Consult a Zamil Steel representative for prices & delivery.

3. “**XSE**” : The term “XSE” is an abbreviation for *exterior severe environments*. It is a premium finish coating system that is designed to perform in the most severe environments.

Zamil Steel does not stock this panel. Any skin thickness and color may be made available subject to extended delivery. Consult a Zamil Steel representative for prices & delivery.



**Base Metal, Metal Substrate and Primer Coat:**

The base metal for standard stocked steel panels has a minimum yield strength of 34.5 kN/cm<sup>2</sup> and conforms to ASTM A792 Grade 50B. The metal substrate and the primer coat for the three finish coatings of steel panels are described in the table below:

**Interior Face Finish Coating:**

The interior face finish coating for XRW and XPD panels is an off-white plain polyester having a nominal thickness of 7 microns. The interior face finish coating of the XSE panel is a 7 microns (nominal thickness) gray colored coat.



Steel Panel Type	Metal Substrate	Primer Coat
XRW	Zinc/aluminum alloy that is 150 g/m <sup>2</sup> (total on both sides) and consists of approximately 55% aluminum and 45% zinc, by weight.	Universal corrosion inhibitive epoxy primer with 5 microns nominal thickness, on both sides.
XPD (Kynar 500)		
XSE	Galvanized according to ASTM A653 Grade SQ 50 Class 1 with zinc coating to G 90.	Highly corrosion – resistant high - film-build primer, on both sides; 25 microns (top) and 15 microns (bottom) nominal thicknesses.

Zamil Steel’s standard pre-painted steel panel is XRW, a modified polyester polymer coated over Zinalume, and is available in all Zamil Steel’s standard colors. The test data of the panel coatings are outlined in **section 8.4**.

More than 80% of Zamil Steel’s customers specify Zamil Steel’s standard XRW pre-painted wall panels. Occasionally they are specified in roof applications in lieu of Zamil Steel’s standard plain Zinalume panel.

Special Panel Coating	Substrate	Coating Description
<b>XRW</b>	Zinalume (AZ150)	Modified Polyester Polymer, 20 microns

Zamil Steel also offers higher performance coating for the roof and wall panels. These coatings are more expensive and may require longer delivery times.

The three upgrades to Zamil Steel’s standard pre-painted Zinalume XRW panels, listed in the table below are outlined in the following pages of this section.

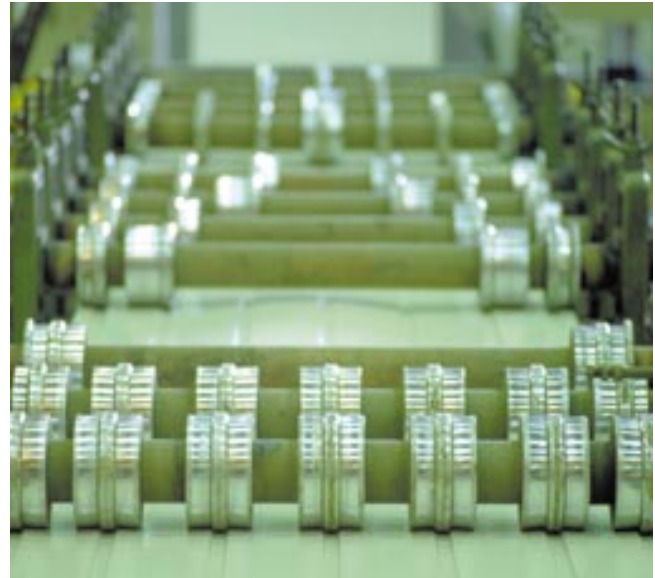

Special Panel Coating	Substrate	Paint Systems	Extended Delivery (Weeks)
<b>XPD (Kynar 500)</b>	Zinalume (AZ150)	20 microns of polyvinyl fluoride paint (also known as PVF <sup>2</sup> and Kynar 500)	20-24*
<b>XSE</b>	Galvanized steel (G 90)		20-24
<b>Powder Coating</b>	Galvanized steel (G 90), or Zinalume	Polyester coating, 60 microns.	0-2

\* XPD in Frost White color in thickness of 0.5, 0.6 and 0.7 mm is available in stock for immediate delivery.

### XRW Coating over Zincalume

XRW is an acronym for “exterior roofing and walling”. The base metal is coated with a corrosion resistant zinc/aluminum alloy produced by a continuous hot-dip process. The result is a sheet with the strength of steel, the superior durability of aluminum and the sacrificial corrosion protection of zinc.

High technology over-cured paints are applied to the Zincalume steel base to produce the high performance Zamil Steel pre-painted panels.

The first stage in painting is the chemical conversion coating. This ensures secure and uniform bonding of the paint while improving corrosion resistance.

Next comes a high technology primer, which further improves the corrosion resistance performance. It is applied to both surfaces and is oven-baked to ensure strong adhesion and toughness.

The final coating is a specially formulated exterior paint with high performance characteristics. This combines elements, which stabilize the adhesion and protect the uniformity of the color across the full expanse of every panel.

### Specifications

Base metal	: ASTMA792 Grade 50 B steel (or equivalent)
Substrate	: Zincalume AZ 150
Pretreatment	: Proprietary corrosion resistant conversion coating.
Primer coat	: Universal corrosion inhibitive epoxy primer, 5 microns nominal thickness, applied to both sides.
Exterior face finish coat	: Modified polyester polymer, 20 microns nominal thickness. The finish coat is available in standard, specially selected colors.
Interior face backing coat	: Off-white polyester, 7 microns nominal thickness.

### COLORBOND® XRW

#### Exterior Roofing and Walling

Revision 3, May 1996  
This literature supersedes all previous issues.

<b>GENERAL DESCRIPTION</b>  COLORBOND XRW prepainted steel has been developed by BHP FPD to provide a high durability, cost effective cladding and roofing material for general exterior use.	<b>TYPICAL USES</b> Roofing and accessories, wall cladding, rainwater goods.
	<b>AUSTRALIAN STANDARD:</b> Substrate - AS 1397 Paint Coating - AS 2728 Category 3

**PREFERRED SUBSTRATES:** ZINCALUME® G550 AZ150  
ZINCALUME G300 AZ150 (D)

**DIMENSIONS:** ZINCALUME G550 AZ150

**For normal supply product**  
**Preferred thickness, mm**

Preferred thickness, mm	Width range, mm		Sheet length, mm
	Strip	Sheet	
0.30	360 - 520, 610 - 1070	610 - 1070	1085 - 4880
0.32	380 - 540, 610 - 1070	610 - 1070	1085 - 4880
0.35, 0.38	250 - 600, 605 - 1220	610 - 1220	1085 - 4880
0.40, 0.42, 0.48, 0.50, 0.55, 0.60	250 - 1240	610 - 1240	1085 - 4880
0.65, 0.70, 0.75, 0.80	450 - 1240	610 - 1240	1085 - 4880
0.85, 0.90, 0.95, 1.0	450 - 1220	610 - 1220	1085 - 4880

**DIMENSIONS:** ZINCALUME G300 AZ150

**For normal supply product**  
**Preferred thickness, mm**

Preferred thickness, mm	Width range, mm		Sheet length, mm
	Strip	Sheet	
0.30	150 - 520, 610 - 1100	300 - 1100	1085 - 4870
0.32	150 - 540, 610 - 1100	610 - 1100	1085 - 4870
0.35	150 - 600, 605 - 1235	300 - 600, 605, - 1235	1085 - 4870
0.38	150 - 600, 605 - 1235	300 - 600, 605, - 1235	1085 - 4870
0.40, 0.42, 0.45, 0.48, 0.50, 0.55	150 - 1240	300 - 1240	1085 - 4870
0.60, 0.65, 0.70, 0.75, 0.80	150 - 1240	610 - 1240	1085 - 4870
0.85, 0.90, 0.95, 1.0	150 - 1235	610 - 1235	1085 - 4870
1.1, 1.2	150 - 1220	300 - 1220	1085 - 4870

For maximum width less than 1200 mm, any width between half maximum and 610 mm is available by negotiation only. Availability applies only to product supplied direct from Western Port and Port Kembla, and may change if supplied from FPD Steel Service Centres.

<b>PRETREATMENT:</b>	Corrosion resistant proprietary conversion coating.
<b>PRIMER COAT:</b>	Universal corrosion inhibitive primer. Nominal thickness 5 µm top side.
<b>FINISH COAT:</b>	Custom formulated system. Nominal thickness 20 µm on the top or weather side. The finish coat is available in 12 standard specially selected colours. Other specially required colours may be available on request. The finish coat can, if required be applied to both sides to provide double-sided product.
<b>BACKING COAT:</b>	Custom formulated Shadow Grey. Nominal film thickness 10 µm.
<b>GLOSS:</b>	Nominal 25% (60°). Other gloss levels may be available upon request.
<b>PROTECTIVE FILM:</b>	COLORBOND XRW can be supplied with CORSTRIP®, a specially designed protective polyethylene strippable film, on the top side. The polyethylene film should be removed from the painted steel strip within 12 months of delivery from BHP FPD.

#### EXPECTED PRODUCT SERVICE PERFORMANCE

Property	Measured After	Test Method	Ref. Standard	Results
Resistance to colour change (D)	QUV (2000 hours)	ASTM G 53	-	Δ E Hunterlab: Intermediate colour #5 units, eg. Wheat
	Natural wet washed exposure (15 years)	ASTM D 2244	AS 2728	Δ E Hunterlab: Light colour: #6 units Int. colour: #9 units Dark colour: #15 units
Resistance to chalking	QUV (2000 hours)	ASTM G 53 AS 1580 481.1.11	AS 2728	Rating range: 1-2
	Natural wet washed exposure (10 years)	AS 1580 481.1.11	AS 2728 (App H1)	Chalk rating: #2



Flat Products  
Division  
BHP Steel

### EXPECTED PRODUCT SERVICE PERFORMANCE (Cont)

Property	Measured After	Test Method	Ref. Standard	Results
Resistance to corrosion	Salt spray (1000 hours)	ASTM B 117 AS 2331.3.1 NCCA B - 2	AS 2728 (App H2)	Blister density: ≤ 1 Blister size: ≤ 52 Undercut from a score: ≤ 2 mm No loss of adhesion
			AS 2728 (App H1)	Edge creep: < 4 mm
	Kesternich (SO <sub>2</sub> ) (50 cycles)	DIN 50018	-	Edge creep: < 4 mm
Resistance to humidity	Cleveland (1000 hours)	NCCA B - 6	AS 2728	Blister density: ≤ 1 Blister size: ≤ 52 No loss of adhesion
Resistance to acids ①	Exposure	ASTM D 1308 (3.1.1)	-	No discolouration No blistering
Resistance to alkalis ①	Exposure	ASTM D 1308 (3.1.1)	-	No discolouration No blistering
Resistance to solvents ①	Exposure	ASTM D 1308 (3.1.1)	-	No discolouration No blistering
Adhesion ②	Natural well washed exposure (15 years)	-	-	No flaking or peeling
Resistance to heat	Exposure 100°C continuous	ASTM D 2244	-	Colour change Δ E Hunterlab: ≤ 3 units
Resistance to fire	Exposure	AS 1530 Pt 3	-	Ignitability index: 0 rating in scale of 0-20 Spread of flame index: 0 rating in scale of 0-10 Heat evolved index: 0 rating in scale of 0-10 Smoke evolved index: 0-1 rating in scale of 0-10
Flexibility	T-bend	AS 2935 (App E) NCCA B - 19	-	7T or less (no cracking)
Resistance to abrasion	Taper Abraser: 1000g CS 10 wheels	AS 2105 (App D) NCCA B - 12	-	≤ 20 mg per 100 cycles
	Scratch	AS 1580 403.1	AS 2728	≥ 2000 g

### GUARANTEED PAINT PROPERTIES

Property	Measured By	Test Method	Ref. Standard	Results
Hardness	Pencil	AS 1580 405.1 NCCA B - 12	AS 2728	HB or harder
Adhesion	Reverse impact	AS 2728 (App E) NCCA B - 6	AS 2728	≥ 10 joules
		AS 2728 (App F) NCCA B - 19	AS 2728	5T or less
	Cross notch	ASTM D3359 (B) NCCA B - 5 AS 1580 408.4	-	No paint removal 0 rating (no removal)
Specular gloss	60° meter	AS 1580 602.2 ASTM D 523	-	15 – 35%

#### NOTE

- ① For most products, the metallurgical ageing process which is inherent in the paint stoving cycle will result in some loss of ductility compared with unprimed product. However, minimum strength levels designated by relevant standards will still be applicable.
- ② Values quoted are for standard COLORBOND XRW colours under normal well washed conditions of exposure. If it is intended to use COLORBOND XRW in an exterior application within 1 km of salt marine locations, severe industrial or abnormally corrosive environments, or in areas not washed by rain (or in applications where it will be wholly or partly buried in the ground), please contact your nearest FPD Sales Office for advice. Improper storage or the use of non-approved roll-forming lubricants may adversely affect colour. Material which becomes wet while in stacks or bundles must be separated and dried (refer AS 2728 Appendix A3).
- ③ COLORBOND XRW has good resistance to accidental spillage of solvents such as methylated spirits, white spirit, mineral turpentine, toluene, trichloroethylene and dilute mineral acids and alkalis. However, all spillages should be immediately removed by water washing and drying.

COLORBOND®, ZINCALUME® and CORSTEEL® are registered trademarks of BHP Steel (JLA) Pty Ltd.

Please ensure you have the current data sheet for this product.

### Flat Products Division - BHP Steel

The BHP Steel Proprietary Company Limited (A.C.N. 204 629 077)  
BHP Steel (AUS) Pty Ltd (A.C.N. 200 249 076)  
BHP Steel (JLA) Pty Ltd (A.C.N. 200 011 074)  
BHP Steel (M&A) Pty Ltd (A.C.N. 204 110 913)

Copyright © 1996 BHP Steel (JLA) Pty Ltd

SYDNEY: (02) 795 6100 MELBOURNE: (03) 9546 2222 BRISBANE: (07) 5345 0955 ADELAIDE: (08) 241 7333 PERTH: (09) 530 0666

Produced by Artprint (08) 9568 2622



Flat Products  
Division  
BHP Steel

### **XPD Coating over Zincalume**

XPD is an acronym for “exterior premium durability”. This polyvinyl fluoride (also known as PVF2 and Kynar 500) coating has long been developed for roof, wall and architectural panel applications which demand high performance in both long-term color and gloss finish durability.

The base material is a zinc/aluminum alloy coated steel sheet. The steel sheet undergoes pretreatment and conversion and is then coated with a corrosion resistant primer before the top coat is applied.

The sophisticated fluorocarbon-based paint system of this coating ensures high color retention.

Zamil Steel's XPD coating is ideal for buildings located 500 meters to 1000 meters from the sea coast or in heavy industrial areas. It is particularly suited for applications such as power stations, airport terminals and other large industrial and commercial projects.

XPD steel panels are stocked in 0.5, 0.6 and 0.7 mm in Frost White color only. Other colors are available but require 20 to 24 weeks extended delivery time.

Performance tests certificates are available upon request.

### **Specifications**

Base metal	: ASTMA792 Grade 50 B steel (or equivalent)
Substrate	: Zincalume AZ 150
Pretreatment	: Proprietary corrosion resistant conversion coating.
Primer coat	: Universal corrosion inhibitive epoxy primer, 5 microns nominal thickness, applied to both sides.
Exterior face finish coat	: Polyvinyl fluoride (PVF2) paint, 20 microns nominal thickness. The finish coat is available in any desired color.
Interior face backing coat	: Off-white polyester, 7 microns nominal thickness.

## COLORBOND® XPD

### Exterior Premium Durability

Revision 3, May 1996  
This literature supersedes all previous issues

#### GENERAL DESCRIPTION

COLORBOND XPD prepainted steel has been developed by BHP FPD to provide premium durability, excellent weatherability and high formability for exterior applications.

#### TYPICAL USES

Applications requiring excellent colour and gloss retention such as roofing.

#### AUSTRALIAN STANDARD:

Substrate - AS 1397  
Paint Coating - AS 2728 Category 3

**PREFERRED SUBSTRATES:** ZINCALUME® G550 AZ150  
ZINCALUME G300 AZ150 (1)

**DIMENSIONS:** ZINCALUME G550 AZ150

For normal supply product

Preferred thickness, mm	Width range, mm		Sheet length, mm
	Strip	Sheet	
0.30	360 - 520, 610 - 1070	610 - 1070	1085 - 4880
0.32	380 - 540, 610 - 1070	610 - 1070	1085 - 4880
0.35, 0.38	250 - 600, 605 - 1220	610 - 1220	1085 - 4880
0.40, 0.42, 0.48, 0.50, 0.55, 0.60	250 - 1240	610 - 1240	1085 - 4880
0.65, 0.70, 0.75, 0.80	450 - 1240	610 - 1240	1085 - 4880
0.85, 0.90, 0.95, 1.0	450 - 1220	610 - 1220	1085 - 4880

**DIMENSIONS:** ZINCALUME G300 AZ150

For normal supply product

Preferred thickness, mm	Width range, mm		Sheet length, mm
	Strip	Sheet	
0.30	150 - 520, 610 - 1100	300 - 1100	1085 - 4870
0.32	150 - 540, 610 - 1100	610 - 1100	1085 - 4870
0.35	150 - 600, 605 - 1235	300 - 600, 605 - 1235	1085 - 4870
0.38	150 - 600, 605 - 1235	300 - 600, 605 - 1235	1085 - 4870
0.40, 0.42, 0.45, 0.48, 0.50, 0.55	150 - 1240	300 - 1240	1085 - 4870
0.60, 0.65, 0.70, 0.75, 0.80	150 - 1240	610 - 1240	1085 - 4870
0.85, 0.90, 0.95, 1.0	150 - 1235	610 - 1235	1085 - 4870
1.1, 1.2	150 - 1220	300 - 1220	1085 - 4870

For maximum width less than 1200 mm, any width between half maximum and 610 mm is available by negotiation only. Availability applies only to product supplied direct from Western Port and Port Kembla, and may change if supplied from FPD Steel Service Centres.

#### PRETREATMENT:

Corrosion resistant proprietary conversion coating.

#### PRIMER COAT:

Corrosion inhibitive primer. Nominal thickness 5 µm each side.

#### FINISH COAT:

Custom formulated system. Nominal thickness 20 µm on the top or weather side. The finish coat is available in 6 standard specially selected colours. Other specially required colours and finishes may be available on request. The finish coat can, if required be applied to both sides to provide a 'double-sided' product.

#### BACKING COAT:

Custom formulated Snowgum Green. Nominal film thickness 5 µm.

#### GLOSS:

Nominal 25% (60°). Other gloss levels may be available upon request.

#### PROTECTIVE FILM:

COLORBOND XPD can be supplied with CORSTIR®<sup>®</sup>, a specially designed polyethylene stripable film, on the top side. The polyethylene film should be removed from the painted steel strip within 12 months of delivery from BHP FPD.

#### EXPECTED PRODUCT SERVICE PERFORMANCE

Property	Measured After	Test Method	Ref Standard	Results
Resistance to colour change (2)	QUV (2000 hours)	ASTM G 53	-	Δ E Hunterlab: Intermediate colour. # 1 unit, eg. Bookata
	Natural well washed exposure (20 years)	ASTM D 2244	AS 2728	Δ E Hunterlab: Light colour: # 6 units Int. colour: # 7 units Dark colour: # 10 units
	Ennisqua 1x10 <sup>6</sup> Langley	-	-	Δ E Hunterlab: # 1 unit
Resistance to chalking	QUV (2000 hours)	ASTM G 53 AS 1580 481.1	AS 2728	Rating range: 0-1
	Natural well washed exposure (20 years)	AS 1580 481.1	AS 2728 (App H1)	Chalk rating: # 2



Flat Products  
Division  
BHP Steel

### EXPECTED PRODUCT SERVICE PERFORMANCE (Cont)

Property	Measured After	Test Method	Ref Standard	Results
Resistance to corrosion	Salt spray (1000 hours)	ASTM B 117 AS 2331 3.1 NCCA # - 2 AS 2728 (App H)	AS 2728 (App H2)	Blister density: # 1 Blister size: # 52 Undercut from a score: # 2 mm No loss of adhesion
	Kesternich (SO <sub>2</sub> ) (50 cycles)	DIN 50018	-	Edge creep: <4 mm
Resistance to humidity	Cleveland (1000 hours)	NCCA # - 6	AS 2728	Blister density: # 1 Blister size: # 52 No loss of adhesion
Resistance to acids ①	Exposure	ASTM D 1308 (3.1.1)	-	No discolouration No blistering
Resistance to alkalis ①	Exposure	ASTM D 1308 (3.1.1)	-	No discolouration No blistering
Resistance to solvents ①	Exposure	ASTM D 1308 (3.1.1)	-	No discolouration No blistering
Adhesion ②	Natural well washed exposure (20 years)	-	-	No flaking or peeling
Resistance to heat	Exposure 100°C continuous	ASTM D 2244	-	Colour change & E Hunterlab: # 3 units
Resistance to fire	Exposure	AS 1530 Pt 3	-	Ignitability index: 0 rating in scale of 0-20 Spread of flame index: 0 rating in scale of 0-10 Heat evolved index: 0 rating in scale of 0-10 Smoke evolved index: 0-1 rating in scale of 0-10
Flexibility	T-bend	AS 2935 (App E) NCCA # - 9	-	7T or less (no cracking)
Resistance to abrasion	Taber Abraser-1000 g	AS 2105 (App D)	-	20 mg per 100 cycles
	CS 10 wheels	NCCA # - 21	-	60 litres/25 µm
	Falling sand	ASTM D 968	-	# 2000 g

### GUARANTEED PAINT PROPERTIES

Property	Measured By	Test Method	Ref Standard	Results
Hardness	Pencil	AS 1580 405.1 NCCA # - 12	AS 2728	HB or harder
Adhesion	Reverse impact	AS 2728 (App E) NCCA # - 6	AS 2728	10 joules
	T-bend	AS 2728 (App F) NCCA # - 19	AS 2728	5T or less
	Cross hatch	ASTM D 3359 (B) NCCA # - 5 AS 1580 408.4	-	No paint removal 0 rating (no removal)
Specular gloss	60° meter	AS 1580 602.2 ASTM D 523	-	15-35%

#### NOTE

- For most products, the metallurgical ageing process which is inherent in the paint stoving cycle will result in some loss of ductility compared with unpainted product. However, minimum strength levels designated by relevant standards will still be applicable.
- Values quoted are for standard COLORBOND XPD colours under normal well washed conditions of exposure. If it is intended to use COLORBOND XPD in an exterior application within 1 km of salt marine locations, severe industrial or abnormally corrosive environments, or in areas not washed by rain (or in applications where it will be wholly or partly buried in the ground), please contact your nearest FPD Sales Office for advice. If it is intended to use COLORBOND XPD for exterior walling or cladding please contact your nearest FPD Sales Office for advice. Improper storage or the use of non-approved roll-forming lubricants may adversely affect colour. Material which becomes wet while in stacks or bundles must be separated and dried prior AS 2728 Appendix A3.
- COLORBOND XPD has good resistance to accidental spillage of solvents such as methylated spirits, white spirit, mineral turpentine, toluene, trichloroethylene and dilute mineral acids and alkalis. However, all spillages should be immediately removed by water washing and drying.

COLORBOND®, ZINCALUME® and CORSTRIP® are registered trademarks of BHP Steel (IL) Pty Ltd.

Please ensure you have the current data sheet for this product.

### Flat Products Division - BHP Steel

The Steelmaker Proprietary Company Limited (A.C.N. 004 628 072)  
BHP Steel (AQ) Pty Ltd. (A.C.N. 000 014 627)  
BHP Steel (SA) Pty Ltd. (A.C.N. 000 011 056)  
BHP Steel (WA) Pty Ltd. (A.C.N. 004 410 833)

Copyright © 1996 BHP Steel (IL) Pty Ltd

SYDNEY: (02) 795 6700 MELBOURNE: (03) 9586 2222 BRISBANE: (07) 3345 0555 ADELAIDE: (08) 249 7333 PERTH: (08) 340 0466

Produced by AdImpact (P) 9958 2425



Flat Products  
Division  
BHP Steel



### XSE Coating over Galvanized G90

XSE is an acronym for "exterior severe environments". This high end coating system employs the latest anti-corrosive steel and coating technology and is ideal for use in severe marine and industrial environments.

The hot-dip galvanized steel substrate undergoes pretreatment and conversion, then a specially developed, high film-build, corrosion resistant primer is applied to both sides.

The color fastness and surface adhesion tests for this product are impressive. Bend tests show a remarkable formability and no loss of adhesion or signs of paint cracking are experienced. The flexibility and performance of XSE makes it suitable for use in the harshest conditions such as severe coastal and tropical environments.

Although XSE coating requires a higher initial investment than other widely used XPD (PVF2) coatings, it offers better value in the long term due to its overall durability.

Zamil Steel does not stock XSE steel panels. Clients should allow us for 20 to 24 weeks extended delivery time for such panels.

Performance tests certificates are also available upon request.

### Specifications

Base metal	: ASTM A653 Grade SS50 Class I steel (or equivalent)
Substrate	: Galvanized G90 (275g/m <sup>2</sup> )
Pretreatment	: Proprietary corrosion resistant conversion coating.
Primer coat	: Highly corrosion resistant high film-build primer on both sides, 25 microns thick on the exterior face and 10 microns thick on the interior face.
Exterior face finish coat	: Polyvinyl fluoride (PVF2) paint, 20 microns nominal thickness.
Interior face backing coat	: Proprietary custom formulated system in gray color, 7 microns nominal thickness.

### COLORBOND® XSE

#### Exterior Severe Environments

Revision 5, May 1996  
This literature supersedes all previous issues

#### GENERAL DESCRIPTION

COLORBOND XSE prepainted steel developed by BHP FPD, combines long term durability, high formability, and exceptional corrosion resistance.

#### TYPICAL USES

Exterior building profiles in applications requiring high formability, good gloss retention, high colour stability and excellent corrosion resistance. Suited to moderately severe marine and industrial environments and sheltered areas not washed by rain, eg. eave linings and domestic house siding.

#### AUSTRALIAN STANDARD:

Substrate - AS 1397  
Paint Coating - AS 2728 Category 3

**PREFERRED SUBSTRATES:** ZINC HI TEN G5505 Z275  
ZINCFORM G3005 Z275

**DIMENSIONS:** ZINC HI TEN G5505 Z275

**For normal supply product**  
Preferred thickness, mm

Preferred thickness, mm	Width range, mm		Sheet length, mm
	Strip	Sheet	
0.30	360 - 520, 610 - 1070	610 - 1070	1085 - 4880
0.32	380 - 540, 610 - 1100	610 - 1100	1085 - 4880
0.35, 0.38	250 - 600, 605 - 1220	610 - 1220	1085 - 4880
0.40, 0.42, 0.48, 0.50, 0.55, 0.60	250 - 1300	610 - 1300	1085 - 4880
0.65, 0.70, 0.75, 0.80	250 - 1300	610 - 1300	1085 - 4880
0.85, 0.90, 0.95, 1.0	250 - 1300	610 - 1300	1085 - 4880

**DIMENSIONS:** ZINCFORM G3005 Z275

**For normal supply product**  
Preferred thickness, mm

Preferred thickness, mm	Width range, mm		Sheet length, mm
	Strip	Sheet	
0.30	150 - 520, 610 - 1070	610 - 1070	1085 - 4870
0.32	150 - 540, 610 - 1100	610 - 1100	1085 - 4870
0.35, 0.38	150 - 600, 605 - 1220	610 - 1220	1085 - 4870
0.40, 0.42, 0.45	150 - 1390	610 - 1390	1085 - 4870
0.48, 0.50	150 - 1510	610 - 1510	1085 - 4870
0.55	150 - 1560	610 - 1560	1085 - 4870
0.60	150 - 1610	610 - 1610	1085 - 4870
0.65	150 - 1660	610 - 1660	1085 - 4870
0.70	150 - 1710	610 - 1710	1085 - 4870
0.75	150 - 1760	610 - 1760	1085 - 4870
0.80, 0.85, 0.90, 0.95, 1.0	150 - 1800	610 - 1800	1085 - 4870
1.1, 1.2, 1.3, 1.4, 1.5, 1.6	150 - 1525	610 - 1525	1085 - 4870

For maximum width less than 1200 mm, any width between half maximum and 610 mm is available by negotiation only. Availability applies only to product supplied direct from Western Port and Port Kembla, and may change if supplied from FPD Steel Service Centres.

#### PRETREATMENT:

Corrosion resistant proprietary conversion coating.

#### PRIMER COAT:

Highly corrosion resistant high film build primer both sides. Nominal film thickness 25 µm both sides for double-sided product, or 25 µm top and 15 µm bottom for single sided.

#### FINISH COAT:

Custom formulated system. Nominal film thickness 20 µm on the top or weather side. The finish coat is available in 6 standard specially selected colours. Other specially required colours may be available on request. The finish coat can if required be applied to both sides to provide a 'double sided' product.

#### BACKING COAT:

Custom formulated systems in Flinders Grey. Nominal film thickness 5 µm.

#### GLOSS:

Nominal 25% (60°). Other gloss levels may be available upon request.

#### PROTECTIVE FILM:

Available on enquiry.

#### EXPECTED PRODUCT SERVICE PERFORMANCE

Property	Measured After	Test Method	Ref. Standard	Results
Resistance to colour change (2)	QUV (2000 hours)	ASTM G 53	--	Δ E Hunterlab: Intermediate colour: # 1 unit, eg. Bookara
	Natural well washed exposure (20 years)	ASTM D 2244	AS 2728	Δ E Hunterlab: Light colour: # 6 units Int. colour: # 7 units Dark colour: # 10 units
	Emmiqua 1x10 <sup>6</sup> Langleys	--	--	Δ E Hunterlab: # 1 unit
Resistance to chalking	QUV (2000 hours)	ASTM G 53 AS 1580 481.1	AS 2728	Rating range: 0-1
	Natural well washed exposure (20 years)	AS 1580 481.1	AS 2728 (App H1)	Chalk rating: # 2



Flat Products  
Division  
BHP Steel

### EXPECTED PRODUCT SERVICE PERFORMANCE (Cont)

Property	Measured After	Test Method	Ref. Standard	Results
Resistance to corrosion	Salt spray (2000 hours)	ASTM B 117 AS 2331 3.1 NCCA B - 2 AS 2728 (App H)	AS 2728 (App H2)	Blister density: $\leq 1$ Blister size: $\leq 52$ Undercut from a score: $\leq 2$ mm No loss of adhesion
	Kesternich (SO <sub>2</sub> ) (50 cycles)	DIN 50018	-	Edge creep: slight ( $\leq 2$ mm) Blisters - nil
Resistance to humidity	Cleveland (1000 hours)	NCCA B - 6	AS 2728	Blister density: $\leq 2$ Blister size: $\leq 52$ No loss of adhesion
Resistance to acids ①	Exposure	ASTM D 1308 (3.1.1)	-	No discolouration No blistering
Resistance to alkalis ①	Exposure	ASTM D 1308 (3.1.1)	-	No discolouration No blistering
Resistance to solvents ①	Exposure	ASTM D 1308 (3.1.1)	-	No discolouration No blistering
Adhesion ②	Natural well washed exposure (20 years)	-	-	No flaking or peeling
Resistance to heat	Exposure 100°C continuous	ASTM D 2244	-	Colour change $\Delta E$ Hunterlab: $\leq 3$ units
Resistance to fire	Exposure	AS 1530 Pt 3	-	Ignitability index: 0 rating in scale of 0-20 Spread of flame index: 0 rating in scale of 0-10 Heat evolved index: 0 rating in scale of 0-10 Smoke evolved index: 0-1 rating in scale of 0-10
Flexibility	T-bend	AS 2935 (App E) NCCA B - 19	-	5T or less (no or less cracking)
Resistance to abrasion	Taber Abraser-1000 g CS 10 wheels	AS 2105 (App D) NCCA B - 21	-	$\leq 20$ mg per 100 cycles
	Falling sand	ASTM D 968	-	60 litres/25 $\mu$ m
	Scratch	AS 1580 403.1	AS 2728	2000 g minimum

### GUARANTEED PAINT PROPERTIES

Property	Measured By	Test Method	Ref. Standard	Results
Hardness	Pencil	AS 1580 405.1 NCCA B - 12	AS 2728	B or harder
Adhesion	Reverse impact	AS 2728 (App E) NCCA B - 6	AS 2728	$\geq 10$ joules
	T-bend	AS 2728 (App F) NCCA B - 19	AS 2728	5T or less
	Cross-hatch	ASTM D 3359 (B) NCCA B - 5 AS 1580 408.4	-	No paint removal 0 rating (no removal)
Specular gloss	60° meter	AS 1580 602.2 ASTM D 523	-	15-35%

#### NOTE

- For most products, the metallurgical ageing process which is inherent in the paint stoving cycle will result in some loss of ductility compared with unpainted product. However, minimum strength levels designed by relevant standards will still be applicable.
- Values quoted are for standard COLORBOND XSE colours under normal well washed conditions of exposure. If it is intended to use COLORBOND XSE in an exterior application within 500m of salt marine locations, severe industrial or abnormally corrosive environments, or in applications where it will be wholly or partly buried in the ground, please contact your nearest FPD Sales office for advice. Improper storage or the use of non-approved roll-forming lubricants may adversely affect colour. Material which becomes wet while in stacks or bundles must be separated and dried (refer AS 2728 Appendix A3).
- COLORBOND XSE has good resistance to accidental spillage of solvents such as methylated spirit, white spirit, mineral turpentine, toluene, trichloroethylene and dilute mineral acids and alkalis. However, all spillages should be immediately removed by water washing and drying.

COLORBOND®, ZNCFORM®, ZINC HETEN® and CORSTAIR® are registered trademarks of BHP Steel (JLA) Pty Ltd.

Please ensure you have the current data sheet for this product.

### Flat Products Division - BHP Steel

The Broken Hill Proprietary Company Limited (A.C.N. 004 028 073)  
BHP Steel (NS) Pty Ltd. (A.C.N. 000 019 625)  
BHP Steel (JA) Pty Ltd. (A.C.N. 000 011 056)  
BHP Steel (SA) Pty Ltd. (A.C.N. 004 418 883)

Copyright © 1996 BHP Steel (JLA) Pty Ltd

SYDNEY: (02) 996 6700 MELBOURNE: (03) 9586 2222 BRISBANE: (07) 3394 0555 ADELAIDE: (08) 243 7333 PERTH: (08) 830 0666

Produced by Antiprint (02) 9988 2822



Flat Products  
Division  
BHP Steel

### Powder Coating over Zincalume

The major advantages of polyester powder coating is that it can be applied locally and therefore quickly. The polyester powders used by Zamil Steel are carefully selected to provide maximum environmental and ultraviolet (sun/heat) protection. Add to that the availability of a multitude of colors and you get the perfect solution: a customized product made to fit your exact needs.

Specifications : ASTM, DIN or BS.

Substrate : Galvanized G-90 Steel, Aluminum, or Zincalume coated steel.

Pretreatment : Standard process to form chromate on basic substrate.

Coating thickness : Standard polyester coating thickness or as per customer's specifications.

Post treatment : By using the latest auto control curing oven, the polyester powder is cured at the required temperature.

Storage : To avoid minor scratches and self-rubbing, the material is kept interleaved with wood-free cellulose.

Powder coating is also applicable to aluminum panels. The specifications of aluminum panels are detailed in **section 8.6**.

Measures	Relevant Standard	Minimum Standard	Performance Result
Gloss level	ASTM D523	±5	±10
Cross cut adhesion	BS 3900 E6, BS 6496 Clause 4.4	G+O	No removal
Dry film hardness	ASTM D 3363	1H	Passed
Scratch hardness	BS 3900 E2	No penetration at 4000 gm.	Passed
Erichesen cupping test	BS 3900 E4	6 mm - No cracking	Passed
Impact test Wt. @ 2.3 mm	BS 6496 Clause 16	No crack	Passed
Mortar resistance	BS 6496 Clause 14	Nil effect	No loss of adhesion No visual change
1000 hours salt spray/acetic acid	BS 6496 Clause 15	No creep beyond 2 mm of scribe. No blisters	Passed
S02-240 hours test	BS 3900 F8	No effect	No blisters. No corrosion
Artificial weathering 200 hours	BS 3900 F3 ASTM D 659	12 months	Well within limits No color change
Natural weathering	Florida Test		In excess of one Munsel Step
Boiling water test	BS 6496 Clause 17	2 hours test	No blistering

- Notes: 1. All the above tests were carried out on aluminum panels of 6" x 4" with a coating thickness of 60 microns ±5.  
2. Values quoted are under normal well-washed conditions of exposure.  
3. Improper storage, prolonged spillage of lubricants, water or corrosive chemicals may effect the coating.

### Cleveland Humidity Test

**BHP**  
Coated Steel Research Laboratories  
Port Kembla  
BHP Research

**ACCELERATED CORROSION TEST REPORT**  
**CLEVELAND HUMIDITY TEST**

**Test Conditions** As per NECA 3E-A

**Evaluation** Evaluated after 1200 hours testing as per ASTM D154-07 for Molecular Weight and as per ASTM D1312-03 for gloss deterioration.

**Sample Details**

Product Name: COLORBOND®  
Top Coat Film Type: Polyurethane  
Total Dry Film Thickness: 32 µm (minimum)  
Top Coat Colour: Mist Green  
Substrate Type: ZINCALUMINE®  
Coil No: K22316  
Initial Gloss: 35

**Test Results**

Test	Test Method	Result
Evaluation of Gloss	ASTM D523-09	30
Evaluation of Blistering	ASTM D154-07	No Blister

**NOTES**

- Gloss measurements were determined using a Gardner Instrument's Glossquad system 57 utilizing a 60° measurement geometry.
- Sample size: 800 mm x 120 mm.
- Laboratory reference: 95-241-01

Date: 7 August 1997  
Report No: 8796103

P. J. Kennedy  
Principal Research Scientist  
Polymer Coatings

The laboratory is registered by the National Association of Testing Authorities, Australia. The tests reported herein have been performed in accordance with its terms of registration. This document shall not be reproduced except in full.

Coated Steel Research Laboratories, Port Kembla, BHP Research, Old Port Road, Port Kembla, NSW 2515, Australia  
P.O. Box 202, Port Kembla, NSW 2515, Australia, Telephone +61 61 52 3748, Facsimile +61 61 52 3745  
NSW 2515 202 07

### Salt Spray Test

**BHP**  
Coated Steel Research Laboratories  
Port Kembla  
BHP Research

**ACCELERATED CORROSION TEST REPORT**  
**SALT SPRAY TEST**

**Test Conditions** As per ASTM B117-90

**Evaluation** Evaluated after 2000 hours under 700 hours as per ASTM D154-90 (Procedure A and Procedure B) as wetted and assessed areas.

**Sample Details**

Product Name: COLORBOND® X200  
Top Coat Film Type: Polyester  
Total Dry Film Thickness: 26 µm  
Top Coat Colour: Mist Green  
Substrate Type: ZINCALUMINE®  
Coil No: 47188-14

**Test Results**

Test	Test Method	Hours	Results
Evaluation of Scratched Area	ASTM D1554-02 Procedure A	750 2000	0 5
Evaluation of Unscratched Area	ASTM D1554-02 Procedure B	750 2000	No Blister no blister

**NOTES**

- Laboratory reference: 95142-03

Date: 7 August 1997  
Report No: 8796103

P. J. Kennedy  
Principal Research Scientist  
Polymer Coatings

The laboratory is registered by the National Association of Testing Authorities, Australia. The tests reported herein have been performed in accordance with its terms of registration. This document shall not be reproduced except in full.

Coated Steel Research Laboratories, Port Kembla, BHP Research, Old Port Road, Port Kembla, NSW 2515, Australia  
P.O. Box 202, Port Kembla, NSW 2515, Australia, Telephone +61 61 52 3748, Facsimile +61 61 52 3745  
NSW 2515 202 07

### Kesternich SO<sub>2</sub> Test

**BHP**  
Port Kembla Laboratories  
BHP Research  
BHP Steel

**ACCELERATED CORROSION TEST REPORT**  
**KESTERNICH SO<sub>2</sub> TEST**  
**PREPARED STEEL**

**Test Conditions**

Method: As per DIN 50048  
Coil Size: 800x1200  
Concentration: 0.2 L SO<sub>2</sub>

**Evaluation** Evaluated at 70 cycles as per ASTM D1554-92 (Procedure A and Procedure B) as wetted and assessed areas.

**Sample Details**

Product Name: COLORBOND® XFD  
Top Coat Film Type: Polyurethane/Polyurethane (PUP)/Kymen 500/50µm 5000  
Total Dry Film Thickness: 32 µm (minimum)  
Top Coat Colour: Polar White  
Substrate Type: ZINCALUMINE®  
Coil No.: X01706

**Test Results**

Test	Test Method	Result
Evaluation of Scratched Area	ASTM D1554-92 Procedure A	9
Evaluation of Unscratched Area	ASTM D1554-92 Procedure B	10 No Blister or red rust

**NOTES**

- Laboratory reference: WUR201/05, PL0251-01

Date: 11 August 1995  
Report No: 8074103

R. S. Kennedy  
Senior Research Associate  
Organic Coatings

The laboratory is registered by the National Association of Testing Authorities, Australia. The tests reported herein have been performed in accordance with its terms of registration. This document shall not be reproduced except in full.

BHP Research, Port Kembla Laboratories, Old Port Road, Port Kembla, New South Wales 2515, Australia  
P.O. Box 202, Port Kembla, New South Wales 2515, Australia, Telephone +61 61 52 3748, Facsimile +61 61 52 3745  
BHP Company Ltd, ASN 054 028 077

### QUV Test

**BHP**  
Coated Steel Research Laboratories  
Port Kembla  
BHP Research

**ACCELERATED TEST REPORT**  
**QUV TEST**

**Test Conditions**

Method: As per ASTM G93-93  
QUV Cabinet: QUV Accelerated Weathering Tester  
UV Lamp Degradation: DVB-311 from Q-Peel Company  
Exposure Cycle: 4 h UV/80%RH, 4 h condensation/70%RH

**Evaluation** Evaluated at 4000 hours as per ASTM D1554-92 for gloss and for mechanical colour difference calculated as per ASTM D2244-95. Chalking was evaluated at 4000 hours as per ASTM D423-04B.

**Sample Details**

Product Name: COLORBOND® X200  
Top Coat Film Type: Polyester  
Top Coat Colour: Mist Green  
Substrate Type: ZINCALUMINE®  
Coil No.: 47188-20  
Initial Gloss: 35

**Test Results**

Test	Test Method	Result
Evaluation of Gloss	ASTM D523-09	3
Color Difference	ASTM D2244-95	2.4
Evaluation of Chalking	ASTM D423-04	9

**NOTES**

- Gloss measurements were determined using a Gardner Instrument's Glossquad system 57 utilizing a 60° measurement geometry.
- UV colour spectra: Mactest 2020+ Spectrophotometer.
- Sample size: 800 mm x 120 mm.
- Laboratory reference: 12142-07

Date: 7 August 1997  
Report No.: 8796103

P. J. Kennedy  
Principal Research Scientist  
Polymer Coatings

The laboratory is registered by the National Association of Testing Authorities, Australia. The tests reported herein have been performed in accordance with its terms of registration. This document shall not be reproduced except in full.

Coated Steel Research Laboratories, Port Kembla, BHP Research, Old Port Road, Port Kembla, NSW 2515, Australia  
P.O. Box 202, Port Kembla, NSW 2515, Australia, Telephone +61 61 52 3748, Facsimile +61 61 52 3745  
NSW 2515 202 07

The tests in this section apply to the exterior face of the panel which is exposed to the outside environment

### Cleveland Humidity Test

**BHP** Fort Klemke Laboratories  
BHP Research  
BHP Steel

**ACCELERATED CORROSION TEST REPORT**  
**CLEVELAND HUMIDITY TEST**

**Test Conditions** As per NCCA 35-4

**Evaluation** Evaluated after 1200 hours testing as per ASTM D174-87 for blistering and as per ASTM D524-89 for gloss deterioration.

**Sample Details**

Product Name: COLORBOND® X100  
Top Coat Film Type: Polyvinylidene Fluoride (PVF2) Ekyar 5000/yle 3000  
Total Dry Film Thickness: 22µm (minimum)  
Top Coat Colour: Polar White  
Substrate Type: ZINCALUMINE®  
Coil No: X3176  
Initial Class: 2P

**Test Results**

Test	Test Method	Result
Evaluation of Gloss	ASTM D524-89	2P
Evaluation of Blistering	ASTM D174-87	No Blistering

**NOTES:**

- Gloss measurements were determined using a Gardner Instrument's Cleaguard system B3 utilizing a 60° measurement geometry.
- Sample size: 150 mm x 150 mm.
- Laboratory reference WEL/01-05, PL/002-01

Date: 11 August 1997  
Report No.: 0791,004

*R. A. Senechal*  
R. A. Senechal  
Senior Research Associate  
Organic Coatings

The laboratory is registered by the National Association of Testing Authorities, Australia. The tests reported herein have been performed in accordance with its terms of registration. This document shall not be reproduced except in full.

BHP Research Fort Klemke Laboratories, Old Port Road, Port Kembla, New South Wales 2505, Australia  
P O Box 202 Port Kembla, New South Wales 2505, Australia. Telephone +61 42 52 2148. Facsimile +61 42 52 2128  
BHP Company Ltd ACN 004 028 077

### Salt Spray Test

**BHP** Fort Klemke Laboratories  
BHP Research  
BHP Steel

**ACCELERATED CORROSION TEST REPORT**  
**SALT SPRAY TEST**

**Test Conditions** As per ASTM B117-90

**Evaluation** Evaluated after 2000 cycles/100 hours as per ASTM D1554-92 (Procedure A and Procedure B) as defined and described above.

**Sample Details**

Product Name: COLORBOND® X100  
Top Coat Film Type: Polyvinylidene Fluoride (PVF2) Ekyar 5000/yle 3000  
Total Dry Film Thickness: 22µm (minimum)  
Top Coat Colour: Polar White  
Substrate Type: ZINCALUMINE®  
Coil No: X3176

**Test Results**

Test	Test Method	Hours	Result
Evaluation of Subst Area	ASTM D1554-92 Procedure A	100	2P
		2000	4
Evaluation of Described Area	ASTM D1554-92 Procedure B	100	2P
		2000	2P No Blistering or corrosion

**NOTES:**

- Laboratory reference WEL/01-05, PL/002-01

Date: 11 August 1997  
Report No.: 0791,004

*R. A. Senechal*  
R. A. Senechal  
Senior Research Associate  
Organic Coatings

The laboratory is registered by the National Association of Testing Authorities, Australia. The tests reported herein have been performed in accordance with its terms of registration. This document shall not be reproduced except in full.

BHP Research Fort Klemke Laboratories, Old Port Road, Port Kembla, New South Wales 2505, Australia  
P O Box 202 Port Kembla, New South Wales 2505, Australia. Telephone +61 42 52 2148. Facsimile +61 42 52 2128  
BHP Company Ltd ACN 004 028 077

### Kesternich SO<sub>2</sub> Test

**BHP** Central Steel Research Laboratories  
Fort Klemke  
BHP Research

**ACCELERATED CORROSION TEST REPORT**  
**KESTERNICH SO<sub>2</sub> TEST**  
**PREPARED STEEL**

**Test Conditions**

Method: As per ISO 9013  
Colour: Kesternich  
Concentration: 0.2 L/SO<sub>2</sub>

**Evaluation** Evaluated at 20 cycles as per ASTM D1554-92 (Procedure A and Procedure B) as defined and described above.

**Sample Details**

Product Name: COLORBOND® X100  
Top Coat Film Type: Polyester  
Total Dry Film Thickness: 22µm  
Top Coat Colour: Rosewood  
Substrate Type: ZINCALUMINE®  
Coil No: B1110

**Test Results**

Test	Test Method	Result
Evaluation of Subst Area	ASTM D1554-92 Procedure A	4
Evaluation of Described Area	ASTM D1554-92 Procedure B	2P No Blister or red staining

**NOTES:**

- Laboratory reference 9201-07

Date: 7 August 1997  
Report No.: 0791,004

*P. J. Kennedy*  
P. J. Kennedy  
Principal Research Scientist  
Polymer Coatings

Central Steel Research Laboratories Fort Klemke, BHP Research Old Port Road, Port Kembla, NSW 2505, Australia  
P O Box 202 Port Kembla, NSW 2505, Australia. Telephone +61 42 52 2148. Facsimile +61 42 52 2128  
ACN 004 028 077

### QUV Test

**BHP** Fort Klemke Laboratories  
BHP Research  
BHP Steel

**ACCELERATED TEST REPORT**  
**QUV TEST**

**Test Conditions**

Method: As per ASTM G15-03  
QUV Cycle: QUV Accelerated Weathering Tester  
UV Lamp Designation: DYS-303 from Q Panel Company  
Exposure Cycle: 4 h UV/60°C, 4 h condensation/20°C

**Evaluation** Evaluated at 2000 test hours as per ASTM D524-89 for gloss and for mechanical colour difference calculated as per ASTM D2444-90. Chalking was evaluated at 2000 test hours as per ASTM D4244-89.

**Sample Details**

Product Name: COLORBOND® X100  
Top Coat Film Type: Polyvinylidene Fluoride (PVF2) Ekyar 5000/yle 3000  
Top Coat Colour: Polar White  
Substrate Type: ZINCALUMINE®  
Coil No: X3176  
Initial Class: 2P

**Test Results**

Test	Test Method	Result
Evaluation of Gloss	ASTM D524-89	2P
		45: Calculated Colour Difference
Evaluation of Chalking	ASTM D4244-89	2P No chalking

**NOTES:**

- Gloss measurements were determined using a Gardner Instrument's Cleaguard system B3 utilizing a 60° measurement geometry.
- ICE colour system: Munsell 300a Spectrophotometer.
- Laboratory reference WEL/01-05, PL/002-01

Date: 11 August 1997  
Report No.: 0791,004

*R. A. Senechal*  
R. A. Senechal  
Senior Research Associate  
Organic Coatings

The laboratory is registered by the National Association of Testing Authorities, Australia. The tests reported herein have been performed in accordance with its terms of registration. This document shall not be reproduced except in full.

BHP Research Fort Klemke Laboratories, Old Port Road, Port Kembla, New South Wales 2505, Australia  
P O Box 202 Port Kembla, New South Wales 2505, Australia. Telephone +61 42 52 2148. Facsimile +61 42 52 2128  
BHP Company Ltd ACN 004 028 077

The tests in this section apply to the exterior face of the panel which is exposed to the outside environment

### Cleveland Humidity Test

**BHP**

Port Kembla Laboratories  
BHP Research  
BHP Steel

**ACCELERATED CORROSION TEST REPORT**  
**CLEVELAND HUMIDITY TEST**

**Test Conditions:** As per NCCA 32-6 or ASTM D4383

**Evaluation:** Evaluated after 1000 hours testing at 60°C as per ASTM D2144-07 for blanching and as per ASTM D153-89 for gloss determination.

**Sample Details:**

Product Name: **COLOURBOND® XSE**

Top Coat Paint Type: Polyvinylidene Fluoride (PVDF) Kynar 500

Total Dry Film Thickness: 47 µm

Top Coat Colour: **Coast White**

Substrate Type: **ZINCALUME®**

Coil No.: **814170**

Initial Gloss: 25

**Test Results:**

Test	Test Method	Result
Evaluation of Gloss	ASTM D2144-07	24
Evaluation of Blanching	ASTM D114-07	No Blanching

**NOTES:**

- Gloss measurements were determined using a Gardner Substratest's Glossgrip system 87 utilizing a 60° measurement geometry.
- Sample size: 100 mm x 150 mm.
- Laboratory reference R3177-01.

Date: 18 August, 1994 S. A. Seneck  
Research Manager  
International Services/Research Consultant

Report No. N94LE01

This laboratory is registered by the National Association of Testing Authorities, Australia. The tests reported herein have been performed in accordance with its terms of registration. This document shall not be reproduced except in full.

BHP Research, Port Kembla Laboratories, Old Port Road, Port Kembla, New South Wales 2505, Australia  
P.O. Box 17, Port Kembla, New South Wales 2505, Australia. Telephone +61 61 75 6148. Facsimile +61 61 75 6120  
BHP Company Ltd. ACN 204 528 277

### Salt Spray Test

**BHP**

Port Kembla Laboratories  
BHP Research  
BHP Steel

**ACCELERATED CORROSION TEST REPORT**  
**SALT SPRAY TEST**

**Test Conditions:** As per ASTM B117-90

**Evaluation:** Evaluated after 1000 cycles (500 hours) as per ASTM D1534-01 (Procedure A and Procedure B) at wet/dry and un-dried areas.

**Sample Details:**

Product Name: **COLOURBOND® XSE**

Top Coat Paint Type: Polyvinylidene Fluoride (PVDF) Kynar 500

Total Dry Film Thickness: 47 µm

Top Coat Colour: **Coast White**

Substrate Type: **ZINCALUME®**

Coil No.: **814170**

**Test Results:**

Test	Test Method	Hours	Results
Evaluation of Salted Area	ASTM D1534-01 Procedure A	150	0
		2000	7
Evaluation of Unsalted Area	ASTM D1534-01 Procedure B	150	0
		2000	0 (No Blanching or corrosion)

**NOTES:**

- Laboratory reference R3177-01.

Date: 18 August, 1994 S. A. Seneck  
Research Manager  
International Services/Research Consultant

Report No. N94LE01

This laboratory is registered by the National Association of Testing Authorities, Australia. The tests reported herein have been performed in accordance with its terms of registration. This document shall not be reproduced except in full.

BHP Research, Port Kembla Laboratories, Old Port Road, Port Kembla, New South Wales 2505, Australia  
P.O. Box 17, Port Kembla, New South Wales 2505, Australia. Telephone +61 61 75 6148. Facsimile +61 61 75 6120  
BHP Company Ltd. ACN 204 528 277

### Kesternich SO<sub>2</sub> Test

**BHP**

Port Kembla Laboratories  
BHP Research  
BHP Steel

**ACCELERATED CORROSION TEST REPORT**  
**KESTERNICH SO<sub>2</sub> TEST**  
**PREPARED STEEL**

**Test Conditions:**

Method: As per ISO 9018

Colour: **Kesternich**

Concentration: **0.1 L SO<sub>2</sub>**

**Evaluation:** Evaluated in 30 and 50 cycles as per ASTM D4344-01 (Procedure A and Procedure B) at wet/dry and un-dried areas.

**Sample Details:**

Product Name: **COLOURBOND® XSE**

Top Coat Paint Type: Polyvinylidene Fluoride (PVDF) Kynar 500

Total Dry Film Thickness: 44 µm

Top Coat Colour: **White**

Substrate Type: **ZINCALUME®**

Coil No.: **A2700**

**Test Results:**

Test	Test Method	Cycles	Result
Evaluation of Salted Area	ASTM D4344-01 Procedure A	30	0
		50	0
Evaluation of Unsalted Area	ASTM D4344-01 Procedure B	30	No blanching or red rust
		50	No blanching or red rust

**NOTES:**

- Laboratory reference R3177-01.

Date: 18 August, 1994 S. A. Seneck  
Research Manager  
International Services/Research Consultant

Report No. N94LE01

This laboratory is registered by the National Association of Testing Authorities, Australia. The tests reported herein have been performed in accordance with its terms of registration. This document shall not be reproduced except in full.

BHP Research, Port Kembla Laboratories, Old Port Road, Port Kembla, New South Wales 2505, Australia  
P.O. Box 17, Port Kembla, New South Wales 2505, Australia. Telephone +61 61 75 6148. Facsimile +61 61 75 6120  
BHP Company Ltd. ACN 204 528 277

### QUV Test

**BHP**

Port Kembla Laboratories  
BHP Research  
BHP Steel

**ACCELERATED TEST REPORT**  
**QUV TEST**

**Test Conditions:**

Method: As per ASTM G55-91

QUV Cycle: Q-Pend Composite, QUV Accelerated Weathering Tester

UV Lamp Designation: **UVB311 Short Q Panel Geometry**

Exposure Cycle: **1 h UV/0.5 h C, 4 h condensation/30°C**

**Evaluation:** Evaluated in 1000 test hours as per ASTM D1534-01 for gloss and for mechanical surface difference reduction as per ASTM D2248-01. Chalking was evaluated at 2000 test hours as per ASTM D4244-89.

**Sample Details:**

Product Name: **COLOURBOND® XSE**

Top Coat Paint Type: Polyvinylidene Fluoride (PVDF) Kynar 500

Top Coat Colour: **Pale White**

Substrate Type: **ZINCALUME® AZ100**

Coil No.: **814108**

Initial Gloss: 10

**Test Results:**

Test	Test Method	Result
Evaluation of Gloss	ASTM D2248-01	20
		ASTM D2248-01
Evaluation of Chalking	ASTM D4244-89	0 (No chalking)

**NOTES:**

- Gloss measurements were determined using a Gardner Substratest's Glossgrip system 87 utilizing a 60° measurement geometry.
- UV colour specter: Mactest 2020 Spectrophotometer.
- Search 800 type tape.
- Laboratory reference R3177-01.

Date: 18 August, 1994 S. A. Seneck  
Research Manager  
International Services/Research Consultant

Report No. N94LE01

This laboratory is registered by the National Association of Testing Authorities, Australia. The tests reported herein have been performed in accordance with its terms of registration. This document shall not be reproduced except in full.

BHP Research, Port Kembla Laboratories, Old Port Road, Port Kembla, New South Wales 2505, Australia  
P.O. Box 17, Port Kembla, New South Wales 2505, Australia. Telephone +61 61 75 6148. Facsimile +61 61 75 6120  
BHP Company Ltd. ACN 204 528 277

The tests in this section apply to the exterior face of the panel which is exposed to the outside environment

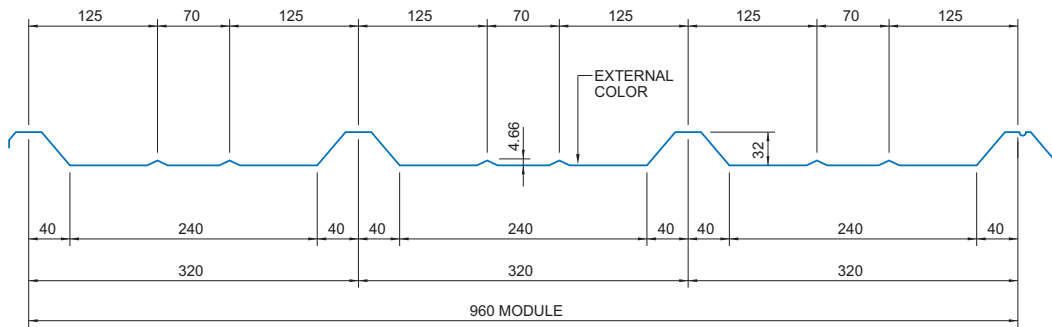

**PROFILE "B" STEEL PANEL**

### Section Properties\*:

Panel Nominal Thickness mm	Nominal Weight kg/m <sup>2</sup>	Nominal Area cm <sup>2</sup>	Top in Compression				Bottom in Compression				Web Shear & Crippling	
			Ix cm <sup>4</sup>	Sx-Top cm <sup>3</sup>	Sx-Bottom cm <sup>3</sup>	Ma kN.m	Ix cm <sup>4</sup>	Sx-Top cm <sup>3</sup>	Sx-Bottom cm <sup>3</sup>	Ma kN.m	Va kN	Pa kN
0.50	4.68	5.96	4.47	1.39	7.79	0.29	2.55	1.53	1.44	0.30	4.51	2.71
0.60	5.62	7.16	6.19	2.07	9.74	0.43	3.46	1.96	1.98	0.40	8.81	4.32
0.70	6.55	8.35	7.57	2.84	11.76	0.59	4.46	2.41	2.64	0.50	12.67	6.16

\*All values are for one meter of panel width.

### Allowable Uniform Loads (kN/m<sup>2</sup>)

Panel Nominal Thickness mm	Number of Spans	Load Case	Span in Meters										
			1.00	1.25	1.50	1.75	2.00	2.25	2.50	2.75	3.00	3.25	3.50
0.50	1	D+L	2.32	1.48	1.03	0.71	0.48	0.33	0.24	0.18	0.14	0.11	0.09
		WP	3.09	1.98	1.38	1.01	0.72	0.50	0.37	0.28	0.21	0.17	0.13
		WS	3.20	1.67	0.97	0.61	0.41	0.29	0.21	0.16	0.12	0.10	0.08
	2	D+L	2.40	1.54	1.07	0.78	0.60	0.47	0.38	0.32	0.27	0.23	0.20
		WP	3.20	2.05	1.42	1.05	0.80	0.63	0.51	0.42	0.36	0.30	0.26
		WS	3.09	1.98	1.38	1.01	0.77	0.61	0.50	0.38	0.29	0.23	0.18
		D+L	3.00	1.92	1.33	0.98	0.75	0.59	0.46	0.35	0.27	0.21	0.17
		WP	4.00	2.56	1.78	1.31	1.00	0.79	0.64	0.52	0.40	0.32	0.25
		WS	3.87	2.47	1.72	1.15	0.77	0.54	0.39	0.30	0.23	0.18	0.14
0.60	1	D+L	3.44	2.20	1.53	0.99	0.66	0.46	0.34	0.25	0.20	0.15	0.12
		WP	4.59	2.94	2.04	1.48	0.99	0.70	0.51	0.38	0.29	0.23	0.18
		WS	4.27	2.27	1.31	0.83	0.55	0.39	0.28	0.21	0.16	0.13	0.10
	2	D+L	3.20	2.05	1.42	1.04	0.80	0.63	0.51	0.42	0.36	0.30	0.26
		WP	4.27	2.73	1.90	1.39	1.07	0.84	0.68	0.56	0.47	0.40	0.35
		WS	4.59	2.94	2.04	1.50	1.15	0.91	0.68	0.51	0.40	0.31	0.25
		D+L	4.00	2.56	1.78	1.31	1.00	0.79	0.64	0.48	0.37	0.29	0.23
		WP	5.33	3.41	2.37	1.74	1.33	1.05	0.85	0.71	0.55	0.44	0.35
		WS	5.73	3.67	2.48	1.56	1.04	0.73	0.53	0.40	0.31	0.25	0.19
0.70	1	D+L	4.72	3.02	1.91	1.20	0.81	0.57	0.41	0.31	0.24	0.19	0.15
		WP	6.30	4.03	2.80	1.81	1.21	0.85	0.62	0.47	0.36	0.28	0.23
		WS	5.34	2.92	1.69	1.07	0.71	0.50	0.37	0.27	0.21	0.17	0.13
	2	D+L	4.00	2.56	1.78	1.31	1.00	0.79	0.64	0.53	0.44	0.38	0.33
		WP	5.34	3.41	2.37	1.74	1.33	1.05	0.85	0.71	0.59	0.50	0.44
		WS	6.30	4.03	2.80	2.06	1.57	1.20	0.88	0.66	0.51	0.40	0.32
		D+L	5.00	3.20	2.22	1.63	1.25	0.99	0.78	0.59	0.45	0.36	0.28
		WP	6.67	4.27	2.96	2.18	1.67	1.32	1.07	0.88	0.68	0.54	0.43
		WS	7.86	5.03	3.19	2.01	1.35	0.95	0.69	0.52	0.40	0.32	0.25

Note : D + L = Dead + Live Load (Deflection limitation: Span/180).

WP = Wind Pressure (Deflection limitation: Span/120).

WS = Wind Suction (Deflection limitation: Span/120).

Material conforming to ASTM A792 Grade 50B (Fy = 34.5 kN/cm<sup>2</sup>) or equivalent.



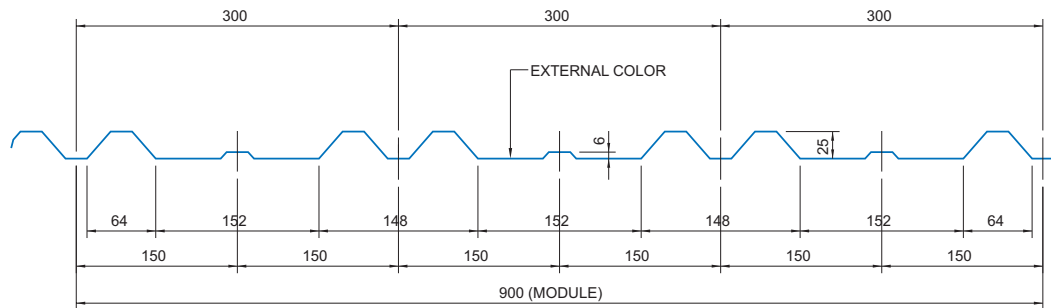

**PROFILE "A" STEEL PANEL**

### Section Properties\*:

Panel Nominal Thickness mm	Nominal Weight kg/m <sup>2</sup>	Nominal Area cm <sup>2</sup>	Top in Compression				Bottom in Compression				Web Shear & Crippling	
			Ix cm <sup>4</sup>	Sx-Top cm <sup>3</sup>	Sx-Bottom cm <sup>3</sup>	Ma kN.m	Ix cm <sup>4</sup>	Sx-Top cm <sup>3</sup>	Sx-Bottom cm <sup>3</sup>	Ma kN.m	Va kN	Pa kN
0.50	4.99	6.36	4.05	2.15	4.97	0.44	3.44	2.22	3.14	0.46	11.89	5.97
0.60	5.99	7.63	5.13	2.96	6.30	0.61	4.50	2.83	4.31	0.58	18.58	9.44
0.70	6.99	8.91	6.15	3.64	7.61	0.75	5.61	3.44	5.55	0.71	25.45	13.40

\*All values are for one meter of panel width.

### Allowable Uniform Loads (kN/m<sup>2</sup>)

Panel Nominal Thickness mm	Number of Spans	Load Case	Span in Meters										
			1.00	1.25	1.50	1.75	2.00	2.25	2.50	2.75	3.00	3.25	3.50
0.50	1	D+L	3.45	1.77	1.02	0.64	0.43	0.30	0.22	0.17	0.13	0.10	0.08
		WP	4.69	2.65	1.54	0.97	0.65	0.46	0.33	0.25	0.19	0.15	0.12
		WS	4.40	2.25	1.30	0.82	0.55	0.39	0.28	0.21	0.16	0.13	0.10
	2	D+L	3.68	2.36	1.64	1.20	0.92	0.73	0.53	0.40	0.31	0.24	0.19
		WP	4.91	3.14	2.18	1.60	1.23	0.97	0.79	0.60	0.46	0.36	0.29
		WS	4.69	3.00	2.09	1.53	1.17	0.93	0.68	0.51	0.39	0.31	0.25
		D+L	4.60	2.94	1.93	1.22	0.82	0.57	0.42	0.31	0.24	0.19	0.15
		WP	6.13	3.92	2.73	1.82	1.22	0.86	0.63	0.47	0.36	0.29	0.23
		WS	5.87	3.75	2.46	1.55	1.04	0.73	0.53	0.40	0.31	0.25	0.19
0.60	1	D+L	4.38	2.24	1.30	0.82	0.55	0.38	0.28	0.21	0.16	0.13	0.10
		WP	6.51	3.36	1.95	1.23	0.82	0.58	0.42	0.32	0.24	0.19	0.15
		WS	5.76	2.95	1.71	1.07	0.72	0.51	0.37	0.28	0.21	0.17	0.13
	2	D+L	4.64	2.97	2.06	1.52	1.16	0.92	0.68	0.51	0.39	0.31	0.25
		WP	6.19	3.96	2.75	2.02	1.55	1.22	0.99	0.76	0.59	0.46	0.37
		WS	6.51	4.17	2.89	2.13	1.63	1.22	0.89	0.67	0.51	0.40	0.32
		D+L	5.80	3.71	2.45	1.54	1.03	0.73	0.53	0.40	0.31	0.24	0.19
		WP	7.73	4.95	3.44	2.31	1.55	1.09	0.79	0.60	0.46	0.37	0.29
		WS	8.13	5.20	3.22	2.03	1.36	0.95	0.70	0.52	0.40	0.32	0.25
0.70	1	D+L	5.25	2.69	1.55	0.98	0.66	0.46	0.34	0.25	0.19	0.15	0.12
		WP	7.87	4.03	2.33	1.47	0.98	0.69	0.50	0.38	0.29	0.23	0.18
		WS	7.18	3.68	2.13	1.34	0.90	0.63	0.46	0.35	0.27	0.21	0.17
	2	D+L	5.68	3.64	2.52	1.85	1.42	1.11	0.81	0.61	0.47	0.37	0.30
		WP	7.58	4.85	3.37	2.47	1.89	1.50	1.21	0.91	0.70	0.55	0.44
		WS	8.00	5.12	3.56	2.61	2.00	1.51	1.10	0.83	0.64	0.50	0.40
		D+L	7.10	4.54	2.93	1.85	1.24	0.87	0.63	0.48	0.37	0.29	0.23
		WP	9.46	6.06	4.21	2.77	1.86	1.30	0.95	0.71	0.55	0.44	0.35
		WS	10.00	6.40	4.01	2.53	1.69	1.19	0.87	0.65	0.50	0.40	0.32

Note : D + L = Dead + Live Load (Deflection limitation: Span/180).  
 WP = Wind Pressure (Deflection limitation: Span/120).  
 WS = Wind Suction (Deflection limitation: Span/120).  
 Material conforming to ASTM A792 Grade 50B (Fy = 34.5 kN/cm<sup>2</sup>) or equivalent.

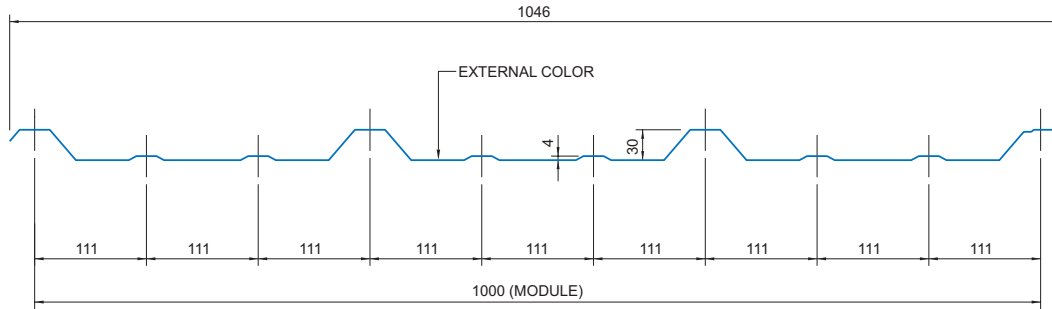

**PROFILE "R" STEEL PANEL**

### Section Properties\*:

Panel Nominal Thickness mm	Nominal Weight kg/m <sup>2</sup>	Nominal Area cm <sup>2</sup>	Top in Compression				Bottom in Compression				Web Shear & Crippling	
			I <sub>x</sub> cm <sup>4</sup>	S <sub>x-Top</sub> cm <sup>3</sup>	S <sub>x-Bottom</sub> cm <sup>3</sup>	Ma kN.m	I <sub>x</sub> cm <sup>4</sup>	S <sub>x-Top</sub> cm <sup>3</sup>	S <sub>x-Bottom</sub> cm <sup>3</sup>	Ma kN.m	V <sub>a</sub> kN	P <sub>a</sub> kN
0.50	4.49	5.73	3.80	1.27	6.53	0.26	2.23	1.49	1.30	0.27	4.61	2.63
0.60	5.39	6.87	5.16	1.91	8.30	0.39	3.01	1.91	1.79	0.37	8.42	4.18
0.70	6.29	8.02	6.48	2.53	10.13	0.52	3.89	2.34	2.34	0.48	12.13	5.95

\*All values are for one meter of panel width.

### Allowable Uniform Loads (kN/m<sup>2</sup>)

Panel Nominal Thickness mm	Number of Spans	Load Case	Span in Meters										
			1.00	1.25	1.50	1.75	2.00	2.25	2.50	2.75	3.00	3.25	3.50
0.50	1	D+L	2.08	1.33	0.92	0.60	0.41	0.28	0.21	0.16	0.12	0.09	0.08
		WP	2.77	1.78	1.23	0.91	0.61	0.43	0.31	0.23	0.18	0.14	0.11
		WS	2.85	1.46	0.85	0.53	0.36	0.25	0.18	0.14	0.11	0.08	0.07
	2	D+L	2.16	1.38	0.96	0.71	0.54	0.43	0.35	0.29	0.24	0.20	0.18
		WP	2.88	1.84	1.28	0.94	0.72	0.57	0.46	0.38	0.32	0.27	0.24
		WS	2.77	1.78	1.23	0.91	0.69	0.55	0.44	0.33	0.25	0.20	0.16
3	D+L	2.70	1.73	1.20	0.88	0.68	0.53	0.39	0.29	0.23	0.18	0.14	
	WP	3.60	2.30	1.60	1.18	0.90	0.71	0.58	0.44	0.34	0.27	0.21	
	WS	3.47	2.22	1.54	1.00	0.67	0.47	0.34	0.26	0.20	0.16	0.13	
0.60	1	D+L	3.12	2.00	1.30	0.82	0.55	0.39	0.28	0.21	0.16	0.13	0.10
		WP	4.16	2.66	1.85	1.23	0.83	0.58	0.42	0.32	0.24	0.19	0.15
		WS	3.85	1.97	1.14	0.72	0.48	0.34	0.25	0.19	0.14	0.11	0.09
	2	D+L	2.96	1.89	1.32	0.97	0.74	0.58	0.47	0.39	0.33	0.28	0.24
		WP	3.95	2.53	1.75	1.29	0.99	0.78	0.63	0.52	0.44	0.37	0.32
		WS	4.16	2.66	1.85	1.36	1.04	0.82	0.59	0.45	0.34	0.27	0.22
3	D+L	3.70	2.37	1.64	1.21	0.93	0.73	0.53	0.40	0.31	0.25	0.19	
	WP	4.93	3.16	2.19	1.61	1.23	0.97	0.79	0.60	0.46	0.37	0.29	
	WS	5.20	3.33	2.15	1.36	0.91	0.64	0.47	0.35	0.27	0.21	0.17	
0.70	1	D+L	4.16	2.66	1.64	1.03	0.69	0.49	0.35	0.27	0.20	0.16	0.13
		WP	5.55	3.55	2.46	1.55	1.04	0.73	0.53	0.40	0.31	0.24	0.19
		WS	4.98	2.55	1.48	0.93	0.62	0.44	0.32	0.24	0.18	0.15	0.12
	2	D+L	3.84	2.46	1.71	1.25	0.96	0.76	0.61	0.51	0.43	0.36	0.31
		WP	5.12	3.28	2.28	1.67	1.28	1.01	0.82	0.68	0.57	0.48	0.42
		WS	5.55	3.55	2.47	1.81	1.39	1.05	0.76	0.57	0.44	0.35	0.28
3	D+L	4.80	3.07	2.13	1.57	1.20	0.92	0.67	0.50	0.39	0.31	0.24	
	WP	6.40	4.09	2.84	2.09	1.60	1.26	1.00	0.75	0.58	0.46	0.36	
	WS	6.93	4.44	2.78	1.75	1.17	0.82	0.60	0.45	0.35	0.28	0.22	

Note : D + L = Dead + Live Load (Deflection limitation: Span/180).

WP = Wind Pressure (Deflection limitation: Span/120).

WS = Wind Suction (Deflection limitation: Span/120).

Material conforming to ASTM A792 Grade 50B (F<sub>y</sub> = 34.5 kN/cm<sup>2</sup>) or equivalent.

# CHAPTER 8 : SINGLE SKIN PANELS

## Section 8.5 : Steel Panels Properties & Load Tables

4 of 8

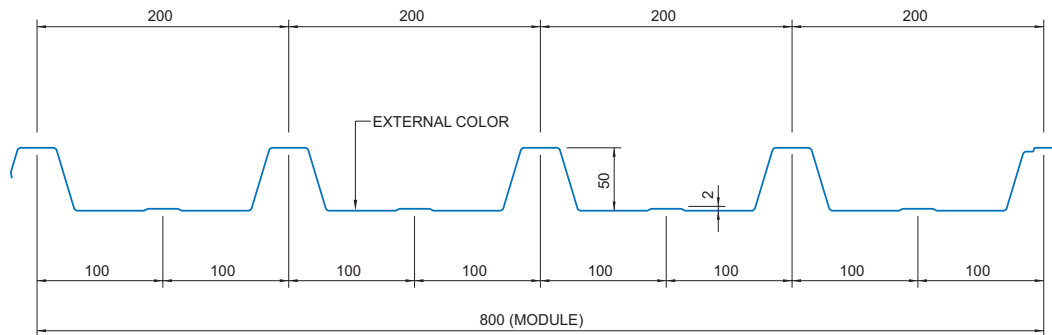

PROFILE "G" STEEL PANEL

### Section Properties\*:

Panel Nominal Thickness mm	Nominal Weight kg/m <sup>2</sup>	Nominal Area cm <sup>2</sup>	Top in Compression				Bottom in Compression				Web Shear & Crippling	
			I <sub>x</sub> cm <sup>4</sup>	S <sub>x-Top</sub> cm <sup>3</sup>	S <sub>x-Bottom</sub> cm <sup>3</sup>	M <sub>a</sub> kN.m	I <sub>x</sub> cm <sup>4</sup>	S <sub>x-Top</sub> cm <sup>3</sup>	S <sub>x-Bottom</sub> cm <sup>3</sup>	M <sub>a</sub> kN.m	V <sub>a</sub> kN	P <sub>a</sub> kN
0.50	5.62	7.16	16.19	3.69	13.13	0.76	11.28	4.51	4.09	0.85	7.60	4.78
0.60	6.74	8.59	22.53	5.34	16.34	1.10	15.02	5.76	5.54	1.14	14.85	7.68
0.70	7.86	10.02	28.94	7.22	19.57	1.49	19.16	7.06	7.17	1.46	25.65	10.99

\*All values are for one meter of panel width.

### Allowable Uniform Loads (kN/m<sup>2</sup>)

Panel Nominal Thickness mm	Number of Spans	Load Case	Span in Meters										
			1.00	1.25	1.50	1.75	2.00	2.25	2.50	2.75	3.00	3.25	3.50
0.50	1	D+L	6.08	3.89	2.70	1.99	1.52	1.20	0.88	0.66	0.51	0.40	0.32
		WP	8.11	5.19	3.60	2.65	2.03	1.60	1.30	1.00	0.77	0.60	0.48
		WS	9.07	5.80	4.03	2.69	1.80	1.27	0.92	0.69	0.53	0.42	0.34
	2	D+L	6.80	4.35	3.02	2.22	1.70	1.34	1.09	0.90	0.76	0.64	0.56
		WP	9.07	5.80	4.03	2.96	2.27	1.79	1.45	1.20	1.01	0.86	0.74
		WS	8.11	5.19	3.60	2.65	2.03	1.60	1.30	1.07	0.90	0.77	0.66
		D+L	8.50	5.44	3.78	2.78	2.13	1.68	1.36	1.12	0.94	0.77	0.61
		WP	11.33	7.25	5.04	3.70	2.83	2.24	1.81	1.50	1.26	1.07	0.91
		WS	10.13	6.48	4.50	3.31	2.53	2.00	1.62	1.31	1.01	0.81	0.64
0.60	1	D+L	8.80	5.63	3.91	2.87	2.20	1.69	1.23	0.92	0.71	0.56	0.45
		WP	11.74	7.51	5.22	3.83	2.93	2.32	1.85	1.39	1.07	0.84	0.67
		WS	12.16	7.78	5.41	3.59	2.40	1.69	1.23	0.92	0.71	0.56	0.45
	2	D+L	9.12	5.84	4.05	2.98	2.28	1.80	1.46	1.21	1.01	0.86	0.74
		WP	12.16	7.78	5.41	3.97	3.04	2.40	1.95	1.61	1.35	1.15	0.99
		WS	11.74	7.51	5.22	3.83	2.93	2.32	1.88	1.55	1.30	1.11	0.96
	3	D+L	11.40	7.30	5.07	3.72	2.85	2.25	1.82	1.51	1.27	1.07	0.85
		WP	15.20	9.73	6.75	4.96	3.80	3.00	2.43	2.01	1.69	1.44	1.24
		WS	14.66	9.38	6.52	4.79	3.67	2.90	2.32	1.74	1.34	1.07	0.85
0.70	1	D+L	11.92	7.63	5.30	3.89	2.98	2.17	1.58	1.19	0.91	0.72	0.58
		WP	15.90	10.17	7.07	5.19	3.97	3.14	2.37	1.78	1.37	1.08	0.86
		WS	15.58	9.97	6.92	4.58	3.07	2.15	1.57	1.18	0.91	0.71	0.57
	2	D+L	11.68	7.48	5.19	3.81	2.92	2.31	1.87	1.54	1.30	1.11	0.95
		WP	15.58	9.97	6.92	5.09	3.89	3.08	2.49	2.06	1.73	1.47	1.27
		WS	15.90	10.17	7.07	5.19	3.97	3.14	2.54	2.10	1.77	1.50	1.30
	3	D+L	14.60	9.34	6.49	4.77	3.65	2.88	2.34	1.93	1.62	1.38	1.09
		WP	19.46	12.46	8.65	6.35	4.87	3.84	3.11	2.57	2.16	1.84	1.59
		WS	19.86	12.71	8.83	6.49	4.97	3.92	2.96	2.22	1.71	1.37	1.08

Note : D + L = Dead + Live Load (Deflection limitation: Span/180).

WP = Wind Pressure (Deflection limitation: Span/120).

WS = Wind Suction (Deflection limitation: Span/120).

Material conforming to ASTM A792 Grade 50B (F<sub>y</sub> = 34.5 kN/cm<sup>2</sup>) or equivalent.

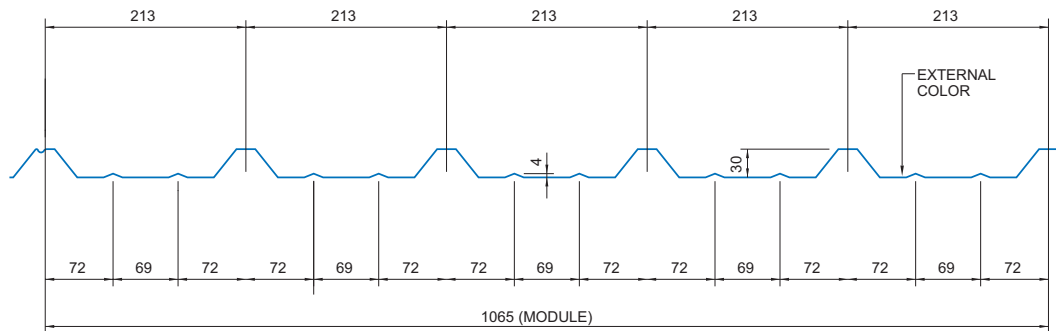

**PROFILE "F" STEEL PANEL**

### Section Properties\*:

Panel Nominal Thickness mm	Nominal Weight kg/m <sup>2</sup>	Nominal Area cm <sup>2</sup>	Top in Compression				Bottom in Compression				Web Shear & Crippling	
			Ix cm <sup>4</sup>	Sx-Top cm <sup>3</sup>	Sx-Bottom cm <sup>3</sup>	Ma kN.m	Ix cm <sup>4</sup>	Sx-Top cm <sup>3</sup>	Sx-Bottom cm <sup>3</sup>	Ma kN.m	Va kN	Pa kN
0.50	4.71	6.00	4.86	1.82	6.91	0.38	3.07	1.86	1.90	0.38	7.74	4.18
0.60	5.65	7.20	6.45	2.59	8.66	0.54	4.16	2.40	2.67	0.50	13.61	6.64
0.70	6.59	8.39	7.75	3.38	10.35	0.70	5.36	2.96	3.57	0.61	19.59	9.44

\*All values are for one meter of panel width.

### Allowable Uniform Loads (kN/m<sup>2</sup>)

Panel Nominal Thickness mm	Number of Spans	Load Case	Span in Meters										
			1.00	1.25	1.50	1.75	2.00	2.25	2.50	2.75	3.00	3.25	3.50
0.50	1	D+L	3.04	1.95	1.23	0.77	0.52	0.36	0.27	0.20	0.15	0.12	0.10
		WP	4.05	2.59	1.80	1.16	0.78	0.55	0.40	0.30	0.23	0.18	0.15
		WS	3.93	2.01	1.16	0.73	0.49	0.34	0.25	0.19	0.15	0.11	0.09
	2	D+L	3.04	1.95	1.35	0.99	0.76	0.60	0.49	0.40	0.34	0.29	0.23
		WP	4.05	2.59	1.80	1.32	1.01	0.80	0.65	0.54	0.45	0.38	0.33
		WS	4.05	2.59	1.80	1.32	1.01	0.80	0.61	0.46	0.35	0.28	0.22
		D+L	3.80	2.43	1.69	1.24	0.95	0.69	0.50	0.38	0.29	0.23	0.18
		WP	5.07	3.24	2.25	1.65	1.27	1.00	0.75	0.56	0.43	0.34	0.27
		WS	5.07	3.24	2.20	1.38	0.93	0.65	0.47	0.36	0.27	0.22	0.17
0.60	1	D+L	4.32	2.76	1.63	1.03	0.69	0.48	0.35	0.26	0.20	0.16	0.13
		WP	5.76	3.69	2.45	1.54	1.03	0.72	0.53	0.40	0.31	0.24	0.19
		WS	5.32	2.73	1.58	0.99	0.67	0.47	0.34	0.26	0.20	0.16	0.12
	2	D+L	4.00	2.56	1.78	1.31	1.00	0.79	0.64	0.53	0.44	0.38	0.31
		WP	5.34	3.41	2.37	1.74	1.33	1.05	0.85	0.71	0.59	0.50	0.44
		WS	5.76	3.69	2.56	1.88	1.44	1.13	0.82	0.62	0.48	0.37	0.30
		D+L	5.00	3.20	2.22	1.63	1.25	0.91	0.66	0.50	0.38	0.30	0.24
		WP	6.67	4.27	2.96	2.18	1.67	1.32	1.00	0.75	0.58	0.45	0.36
		WS	7.20	4.61	2.98	1.87	1.26	0.88	0.64	0.48	0.37	0.29	0.23
0.70	1	D+L	5.60	3.38	1.96	1.23	0.83	0.58	0.42	0.32	0.24	0.19	0.15
		WP	7.47	4.78	2.94	1.85	1.24	0.87	0.63	0.48	0.37	0.29	0.23
		WS	6.51	3.51	2.03	1.28	0.86	0.60	0.44	0.33	0.25	0.20	0.16
	2	D+L	4.88	3.12	2.17	1.59	1.22	0.96	0.78	0.65	0.54	0.46	0.37
		WP	6.51	4.17	2.89	2.13	1.63	1.29	1.04	0.86	0.72	0.62	0.53
		WS	7.47	4.78	3.32	2.44	1.87	1.44	1.05	0.79	0.61	0.48	0.38
		D+L	6.10	3.90	2.71	1.99	1.53	1.10	0.80	0.60	0.46	0.36	0.29
		WP	8.13	5.20	3.61	2.66	2.03	1.61	1.20	0.90	0.69	0.55	0.44
		WS	9.33	5.97	3.84	2.42	1.62	1.14	0.83	0.62	0.48	0.38	0.30

Note : D + L = Dead + Live Load (Deflection limitation: Span/180).

WP = Wind Pressure (Deflection limitation: Span/120).

WS = Wind Suction (Deflection limitation: Span/120).

Material conforming to ASTM A792 Grade 50B (Fy = 34.5 kN/cm<sup>2</sup>) or equivalent.

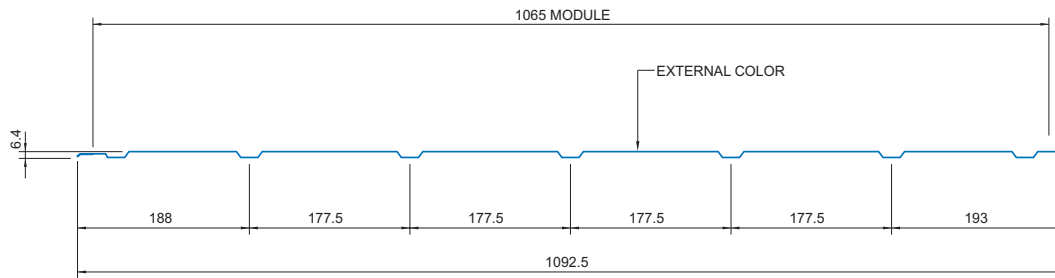

**PROFILE "C" STEEL PANEL**

### Section Properties\*:

Panel Nominal Thickness mm	Nominal Weight kg/m <sup>2</sup>	Nominal Area cm <sup>2</sup>	Top in Compression				Bottom in Compression				Web Shear & Crippling	
			Ix cm <sup>4</sup>	Sx-Top cm <sup>3</sup>	Sx-Bottom cm <sup>3</sup>	Ma kN.m	Ix cm <sup>4</sup>	Sx-Top cm <sup>3</sup>	Sx-Bottom cm <sup>3</sup>	Ma kN.m	Va kN	Pa kN
0.50	4.22	5.38	0.12	0.32	0.35	0.07	0.19	0.31	1.98	0.06	4.20	5.58
0.60	5.06	6.45	0.17	0.40	0.56	0.08	0.23	0.43	2.50	0.09	5.25	8.68
0.70	5.91	7.53	0.22	0.49	0.82	0.10	0.28	0.52	3.00	0.11	6.30	12.18

\*All values are for one meter of panel width.

### Allowable Uniform Loads (kN/m<sup>2</sup>)

Panel Nominal Thickness mm	Number of Spans	Load Case	Span in Meters										
			1.00	1.25	1.50	1.75	2.00	2.25	2.50	2.75	3.00	3.25	3.50
0.50	1	D+L	0.10	0.05	0.03	0.02	0.01	0.01	0.01	0.00	0.00	0.00	0.00
		WP	0.15	0.08	0.05	0.03	0.02	0.01	0.01	0.01	0.01	0.00	0.00
		WS	0.24	0.12	0.07	0.05	0.03	0.02	0.02	0.01	0.01	0.01	0.01
	2	D+L	0.25	0.13	0.07	0.05	0.03	0.02	0.02	0.01	0.01	0.01	0.01
		WP	0.37	0.19	0.11	0.07	0.05	0.03	0.02	0.02	0.01	0.01	0.01
		WS	0.59	0.30	0.17	0.11	0.07	0.05	0.04	0.03	0.02	0.02	0.01
		D+L	0.19	0.10	0.06	0.04	0.02	0.02	0.01	0.01	0.01	0.01	0.00
		WP	0.29	0.15	0.09	0.05	0.04	0.03	0.02	0.01	0.01	0.01	0.01
		WS	0.46	0.23	0.14	0.09	0.06	0.04	0.03	0.02	0.02	0.01	0.01
0.60	1	D+L	0.15	0.07	0.04	0.03	0.02	0.01	0.01	0.01	0.01	0.00	0.00
		WP	0.22	0.11	0.06	0.04	0.03	0.02	0.01	0.01	0.01	0.01	0.01
		WS	0.29	0.15	0.09	0.05	0.04	0.03	0.02	0.01	0.01	0.01	0.01
	2	D+L	0.35	0.18	0.10	0.07	0.04	0.03	0.02	0.02	0.01	0.01	0.01
		WP	0.52	0.27	0.16	0.10	0.07	0.05	0.03	0.03	0.02	0.02	0.01
		WS	0.71	0.36	0.21	0.13	0.09	0.06	0.05	0.03	0.03	0.02	0.02
		D+L	0.27	0.14	0.08	0.05	0.03	0.02	0.02	0.01	0.01	0.01	0.01
		WP	0.41	0.21	0.12	0.08	0.05	0.04	0.03	0.02	0.02	0.01	0.01
		WS	0.56	0.28	0.16	0.10	0.07	0.05	0.04	0.03	0.02	0.02	0.01
0.70	1	D+L	0.19	0.10	0.06	0.04	0.02	0.02	0.01	0.01	0.01	0.01	0.00
		WP	0.28	0.14	0.08	0.05	0.04	0.02	0.02	0.01	0.01	0.01	0.01
		WS	0.36	0.18	0.11	0.07	0.04	0.03	0.02	0.02	0.01	0.01	0.01
	2	D+L	0.45	0.23	0.13	0.08	0.06	0.04	0.03	0.02	0.02	0.01	0.01
		WP	0.67	0.35	0.20	0.13	0.08	0.06	0.04	0.03	0.02	0.02	0.02
		WS	0.86	0.44	0.25	0.16	0.11	0.08	0.05	0.04	0.03	0.03	0.02
		D+L	0.35	0.18	0.10	0.07	0.04	0.03	0.02	0.02	0.01	0.01	0.01
		WP	0.53	0.27	0.16	0.10	0.07	0.05	0.03	0.03	0.02	0.02	0.01
		WS	0.68	0.35	0.20	0.13	0.08	0.06	0.04	0.03	0.03	0.02	0.02

Note : D + L = Dead + Live Load (Deflection limitation: Span/180).

WP = Wind Pressure (Deflection limitation: Span/120).

WS = Wind Suction (Deflection limitation: Span/120).

Material conforming to ASTM A792 Grade 50B (Fy = 34.5 kN/cm<sup>2</sup>) or equivalent.

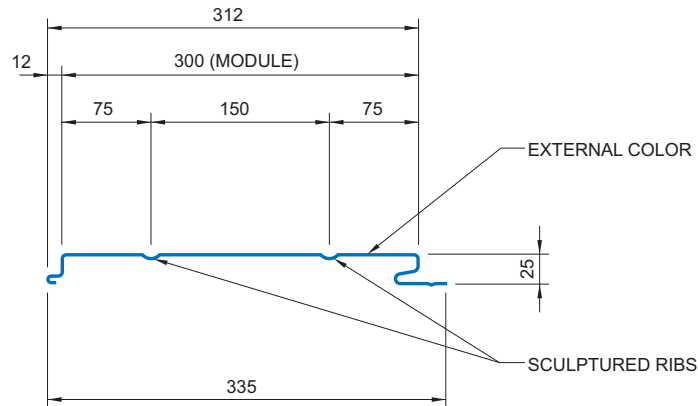

**PROFILE "D" STEEL PANEL**

### Section Properties\*:

Panel Nominal Thickness mm	Nominal Weight kg/m <sup>2</sup>	Nominal Area cm <sup>2</sup>	Top in Compression				Bottom in Compression				Web Shear & Crippling	
			Ix cm <sup>4</sup>	Sx-Top cm <sup>3</sup>	Sx-Bottom cm <sup>3</sup>	Ma kN.m	Ix cm <sup>4</sup>	Sx-Top cm <sup>3</sup>	Sx-Bottom cm <sup>3</sup>	Ma kN.m	Va kN	Pa kN
0.50	5.38	6.85	1.93	1.17	1.82	0.24	3.00	7.94	1.36	0.28	3.67	4.09
0.60	6.45	8.22	2.62	1.62	2.33	0.33	3.89	10.00	1.76	0.36	4.58	6.37
0.70	7.53	9.59	3.36	2.13	2.87	0.44	4.82	12.09	2.17	0.45	5.50	8.94

\*All values are for one meter of panel width.

### Allowable Uniform Loads (kN/m<sup>2</sup>)

Panel Nominal Thickness mm	Number of Spans	Load Case	Span in Meters										
			1.00	1.25	1.50	1.75	2.00	2.25	2.50	2.75	3.00	3.25	3.50
0.50	1	D+L	1.65	0.84	0.49	0.31	0.21	0.14	0.11	0.08	0.06	0.05	0.04
		WP	2.47	1.26	0.73	0.46	0.31	0.22	0.16	0.12	0.09	0.07	0.06
		WS	2.99	1.91	1.14	0.72	0.48	0.34	0.25	0.18	0.14	0.11	0.09
	2	D+L	2.24	1.43	1.00	0.73	0.50	0.35	0.25	0.19	0.15	0.12	0.09
		WP	2.99	1.91	1.33	0.98	0.74	0.52	0.38	0.29	0.22	0.17	0.14
		WS	2.56	1.64	1.14	0.84	0.64	0.51	0.41	0.34	0.28	0.24	0.21
		D+L	2.80	1.59	0.92	0.58	0.39	0.27	0.20	0.15	0.12	0.09	0.07
		WP	3.73	2.39	1.38	0.87	0.58	0.41	0.30	0.22	0.17	0.14	0.11
		WS	3.20	2.05	1.42	1.04	0.80	0.63	0.46	0.35	0.27	0.21	0.17
0.60	1	D+L	2.23	1.14	0.66	0.42	0.28	0.20	0.14	0.11	0.08	0.07	0.05
		WP	3.35	1.72	0.99	0.63	0.42	0.29	0.21	0.16	0.12	0.10	0.08
		WS	3.84	2.46	1.48	0.93	0.62	0.44	0.32	0.24	0.18	0.15	0.12
	2	D+L	2.88	1.84	1.28	0.94	0.67	0.47	0.35	0.26	0.20	0.16	0.13
		WP	3.84	2.46	1.71	1.25	0.96	0.71	0.52	0.39	0.30	0.24	0.19
		WS	3.52	2.25	1.56	1.15	0.88	0.70	0.56	0.47	0.39	0.33	0.28
	3	D+L	3.60	2.16	1.25	0.79	0.53	0.37	0.27	0.20	0.16	0.12	0.10
		WP	4.80	3.07	1.87	1.18	0.79	0.56	0.40	0.30	0.23	0.19	0.15
		WS	4.40	2.82	1.96	1.44	1.10	0.82	0.60	0.45	0.35	0.28	0.22
0.70	1	D+L	2.87	1.47	0.85	0.53	0.36	0.25	0.18	0.14	0.11	0.08	0.07
		WP	4.30	2.20	1.27	0.80	0.54	0.38	0.28	0.21	0.16	0.13	0.10
		WS	4.80	3.07	1.83	1.15	0.77	0.54	0.39	0.30	0.23	0.18	0.14
	2	D+L	3.60	2.30	1.60	1.18	0.86	0.61	0.44	0.33	0.26	0.20	0.16
		WP	4.80	3.07	2.13	1.57	1.20	0.90	0.66	0.50	0.38	0.30	0.24
		WS	4.69	3.00	2.09	1.53	1.17	0.93	0.75	0.62	0.52	0.43	0.35
	3	D+L	4.50	2.77	1.60	1.01	0.68	0.47	0.35	0.26	0.20	0.16	0.13
		WP	6.00	3.84	2.40	1.51	1.01	0.71	0.52	0.39	0.30	0.24	0.19
		WS	5.87	3.75	2.61	1.92	1.46	1.02	0.74	0.56	0.43	0.34	0.27

Note : D + L = Dead + Live Load (Deflection limitation: Span/180).

WP = Wind Pressure (Deflection limitation: Span/120).

WS = Wind Suction (Deflection limitation: Span/120).

Material conforming to ASTM A792 Grade 50B (Fy = 34.5 kN/cm<sup>2</sup>) or equivalent.

# CHAPTER 8 : SINGLE SKIN PANELS

## Section 8.5 : Steel Panels Properties & Load Tables

8 of 8

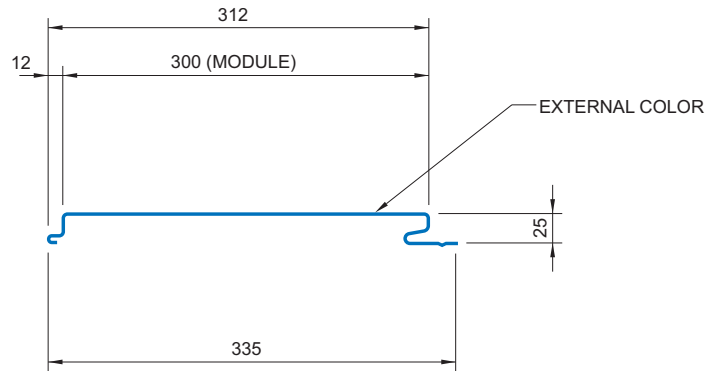

**PROFILE "E" STEEL PANEL**

### Section Properties\*:

Panel Nominal Thickness mm	Nominal Weight kg/m <sup>2</sup>	Nominal Area cm <sup>2</sup>	Top in Compression				Bottom in Compression				Web Shear & Crippling	
			Ix cm <sup>4</sup>	Sx-Top cm <sup>3</sup>	Sx-Bottom cm <sup>3</sup>	Ma kN.m	Ix cm <sup>4</sup>	Sx-Top cm <sup>3</sup>	Sx-Bottom cm <sup>3</sup>	Ma kN.m	Va kN	Pa kN
0.50	5.38	6.85	1.93	1.17	1.82	0.24	3.00	7.94	1.36	0.28	3.67	4.09
0.60	6.45	8.22	2.62	1.62	2.33	0.33	3.89	10.00	1.76	0.36	4.58	6.37
0.70	7.53	9.59	3.36	2.13	2.87	0.44	4.82	12.09	2.17	0.45	5.50	8.94

\*All values are for one meter of panel width.

### Allowable Uniform Loads (kN/m<sup>2</sup>)

Panel Nominal Thickness mm	Number of Spans	Load Case	Span in Meters										
			1.00	1.25	1.50	1.75	2.00	2.25	2.50	2.75	3.00	3.25	3.50
0.50	1	D+L	1.65	0.84	0.49	0.31	0.21	0.14	0.11	0.08	0.06	0.05	0.04
		WP	2.47	1.26	0.73	0.46	0.31	0.22	0.16	0.12	0.09	0.07	0.06
		WS	2.99	1.91	1.14	0.72	0.48	0.34	0.25	0.18	0.14	0.11	0.09
	2	D+L	2.24	1.43	1.00	0.73	0.50	0.35	0.25	0.19	0.15	0.12	0.09
		WP	2.99	1.91	1.33	0.98	0.74	0.52	0.38	0.29	0.22	0.17	0.14
		WS	2.56	1.64	1.14	0.84	0.64	0.51	0.41	0.34	0.28	0.24	0.21
		D+L	2.80	1.59	0.92	0.58	0.39	0.27	0.20	0.15	0.12	0.09	0.07
		WP	3.73	2.39	1.38	0.87	0.58	0.41	0.30	0.22	0.17	0.14	0.11
		WS	3.20	2.05	1.42	1.04	0.80	0.63	0.46	0.35	0.27	0.21	0.17
0.60	1	D+L	2.23	1.14	0.66	0.42	0.28	0.20	0.14	0.11	0.08	0.07	0.05
		WP	3.35	1.72	0.99	0.63	0.42	0.29	0.21	0.16	0.12	0.10	0.08
		WS	3.84	2.46	1.48	0.93	0.62	0.44	0.32	0.24	0.18	0.15	0.12
	2	D+L	2.88	1.84	1.28	0.94	0.67	0.47	0.35	0.26	0.20	0.16	0.13
		WP	3.84	2.46	1.71	1.25	0.96	0.71	0.52	0.39	0.30	0.24	0.19
		WS	3.52	2.25	1.56	1.15	0.88	0.70	0.56	0.47	0.39	0.33	0.28
	3	D+L	3.60	2.16	1.25	0.79	0.53	0.37	0.27	0.20	0.16	0.12	0.10
		WP	4.80	3.07	1.87	1.18	0.79	0.56	0.40	0.30	0.23	0.19	0.15
		WS	4.40	2.82	1.96	1.44	1.10	0.82	0.60	0.45	0.35	0.28	0.22
0.70	1	D+L	2.87	1.47	0.85	0.53	0.36	0.25	0.18	0.14	0.11	0.08	0.07
		WP	4.30	2.20	1.27	0.80	0.54	0.38	0.28	0.21	0.16	0.13	0.10
		WS	4.80	3.07	1.83	1.15	0.77	0.54	0.39	0.30	0.23	0.18	0.14
	2	D+L	3.60	2.30	1.60	1.18	0.86	0.61	0.44	0.33	0.26	0.20	0.16
		WP	4.80	3.07	2.13	1.57	1.20	0.90	0.66	0.50	0.38	0.30	0.24
		WS	4.69	3.00	2.09	1.53	1.17	0.93	0.75	0.62	0.52	0.43	0.35
	3	D+L	4.50	2.77	1.60	1.01	0.68	0.47	0.35	0.26	0.20	0.16	0.13
		WP	6.00	3.84	2.40	1.51	1.01	0.71	0.52	0.39	0.30	0.24	0.19
		WS	5.87	3.75	2.61	1.92	1.46	1.02	0.74	0.56	0.43	0.34	0.27

Note : D + L = Dead + Live Load (Deflection limitation: Span/180).  
 WP = Wind Pressure (Deflection limitation: Span/120).  
 WS = Wind Suction (Deflection limitation: Span/120).  
 Material conforming to ASTM A792 Grade 50B (Fy = 34.5 kN/cm<sup>2</sup>) or equivalent.

All Zamil Steel aluminum panels conform to ASTM B209 Alloy 3003 Temper H26 (or equivalent). Zamil Steel offers 0.7 mm (nominal thickness) aluminum panels in three finishes.

1. Plain aluminum panels: This is suitable mainly for roof applications in moderate environments.
2. Powder coated aluminum panels: Powder coating, in almost any color, can be applied to plain aluminum panels (see **section 8.3** for powder coating specifications). The RAL color of the paint must be provided at time of order. This type of finish is suitable for roof and walls in moderate environments.
3. Environ coated aluminum panels: This is stocked in Frost White color only. Other colors of Environ are available upon request but require an extended delivery of 20 - 24 weeks. The specifications of the Environ coated aluminum panel are detailed below:

### Base Material

The base material for these panels is aluminum pretreated by chromate conversion. Zamil Steel offers aluminum panels in one nominal thickness only; 0.7 mm.

### Primer Coat

The pretreated aluminum panel is coated, on both sides, with 5 microns (nominal) thick Environ primer.

### Exterior Face Finish

The exterior face finish is coated with the Environ paint system, a proprietary paint system developed and patented by PPG Coatings, one of the world's top coating specialists. This highly acclaimed coating system, (an acrylic emulsion system) is applied on a nominal thickness of 20 microns and has excellent weathering properties that contribute to superior performance.

### Interior Face Finish

The interior face finish coating is a 5 microns thick (nominal) Frost White wash coat.

Through laboratory and environmental testing the Environ coating system used for the aluminum panels at Zamil Steel has proven to have excellent physical properties and to greatly improve:

- Resistance to chalking
- Color retention
- Corrosion resistance
- Durability



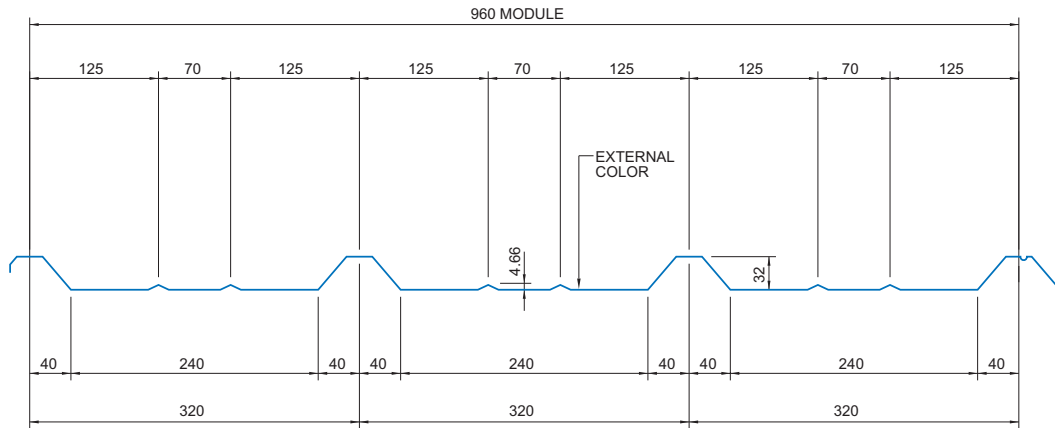

**PROFILE "B" ALUMINUM PANEL**

### Section Properties\*:

Panel Nominal Thickness mm	Weight kg/m <sup>2</sup>	Area cm <sup>2</sup>	Top in Compression				Bottom in Compression				Web Shear & Crippling	
			Ix cm <sup>4</sup>	Sx-Top cm <sup>3</sup>	Sx-Bottom cm <sup>3</sup>	Ma kN.m	Ix cm <sup>4</sup>	Sx-Top cm <sup>3</sup>	Sx-Bottom cm <sup>3</sup>	Ma kN.m	Va kN	Pa kN
0.70	2.31	8.34	7.57	2.84	11.76	0.27	4.46	2.41	2.64	0.23	5.93	2.88

\*All values are for one meter of panel width.

### Allowable Uniform Loads (kN/m<sup>2</sup>)

Panel Nominal Thickness mm	Number of Spans	Load Case	Span in Meters										
			1.00	1.25	1.50	1.75	2.00	2.25	2.50	2.75	3.00	3.25	3.50
0.70	1	D+L	2.16	1.14	0.66	0.42	0.28	0.20	0.14	0.11	0.08	0.06	0.05
		WP	2.88	1.71	0.99	0.62	0.42	0.29	0.21	0.16	0.12	0.10	0.08
		WS	1.97	1.01	0.58	0.37	0.25	0.17	0.13	0.09	0.07	0.06	0.05
	2	D+L	1.84	1.18	0.82	0.60	0.46	0.36	0.29	0.24	0.20	0.16	0.13
		WP	2.45	1.57	1.09	0.80	0.61	0.48	0.39	0.32	0.27	0.23	0.19
		WS	2.88	1.84	1.28	0.89	0.59	0.42	0.30	0.23	0.18	0.14	0.11
	3	D+L	2.30	1.47	1.02	0.75	0.53	0.37	0.27	0.20	0.16	0.12	0.10
		WP	3.07	1.96	1.36	1.00	0.77	0.55	0.40	0.30	0.23	0.19	0.15
		WS	3.60	1.90	1.10	0.69	0.46	0.33	0.24	0.18	0.14	0.11	0.09

Note : D + L = Dead + Live Load (Deflection limitation: Span/180).  
 WP = Wind Pressure (Deflection limitation: Span/120).  
 WS = Wind Suction (Deflection limitation: Span/120).  
 Material conforming to ALLOY 3003 H26 (Fy = 16.15 kN/cm<sup>2</sup>) or equivalent.

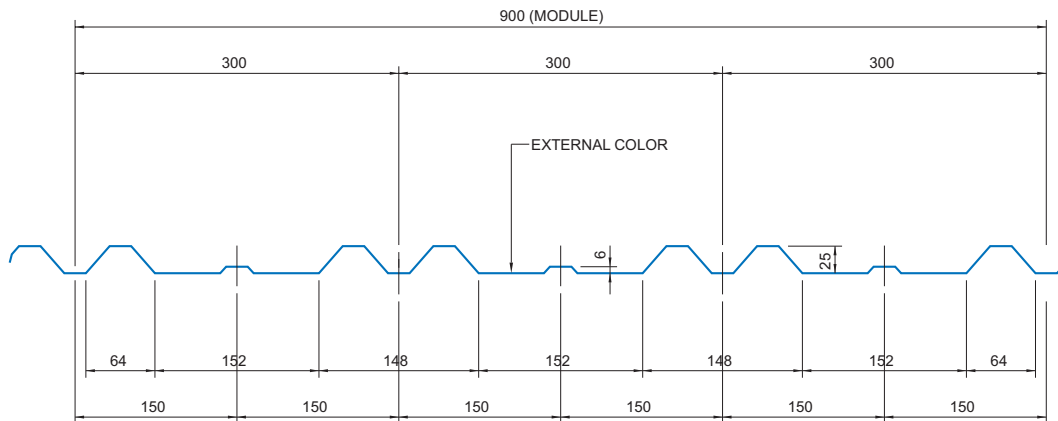

**PROFILE "A" ALUMINUM PANEL**

### Section Properties\*:

Panel Nominal Thickness mm	Weight kg/m <sup>2</sup>	Area cm <sup>2</sup>	Top in Compression				Bottom in Compression				Web Shear & Crippling	
			I <sub>x</sub> cm <sup>4</sup>	S <sub>x-Top</sub> cm <sup>3</sup>	S <sub>x-Bottom</sub> cm <sup>3</sup>	Ma kN.m	I <sub>x</sub> cm <sup>4</sup>	S <sub>x-Top</sub> cm <sup>3</sup>	S <sub>x-Bottom</sub> cm <sup>3</sup>	Ma kN.m	V <sub>a</sub> kN	P <sub>a</sub> kN
0.70	2.47	8.90	6.15	3.64	7.61	0.35	5.61	3.44	5.55	0.33	11.91	6.27

\*All values are for one meter of panel width.

### Allowable Uniform Loads (kN/m<sup>2</sup>)

Panel Nominal Thickness mm	Number of Spans	Load Case	Span in Meters										
			1.00	1.25	1.50	1.75	2.00	2.25	2.50	2.75	3.00	3.25	3.50
0.70	1	D+L	1.81	0.93	0.54	0.34	0.23	0.16	0.12	0.09	0.07	0.05	0.04
		WP	2.71	1.39	0.80	0.51	0.34	0.24	0.17	0.13	0.10	0.08	0.06
		WS	2.47	1.27	0.73	0.46	0.31	0.22	0.16	0.12	0.09	0.07	0.06
	2	D+L	2.64	1.69	1.17	0.81	0.55	0.38	0.28	0.21	0.16	0.13	0.10
		WP	3.52	2.25	1.56	1.15	0.82	0.57	0.42	0.31	0.24	0.19	0.15
		WS	3.73	2.39	1.66	1.11	0.75	0.52	0.38	0.29	0.22	0.17	0.14
	3	D+L	3.30	1.75	1.01	0.64	0.43	0.30	0.22	0.16	0.13	0.10	0.08
		WP	4.40	2.62	1.52	0.96	0.64	0.45	0.33	0.25	0.19	0.15	0.12
		WS	4.67	2.39	1.38	0.87	0.58	0.41	0.30	0.22	0.17	0.14	0.11

Note : D + L = Dead + Live Load (Deflection limitation: Span/180).

WP = Wind Pressure (Deflection limitation: Span/120).

WS = Wind Suction (Deflection limitation: Span/120).

Material conforming to ALLOY 3003 H26 (F<sub>y</sub> = 16.15 kN/cm<sup>2</sup>) or equivalent.

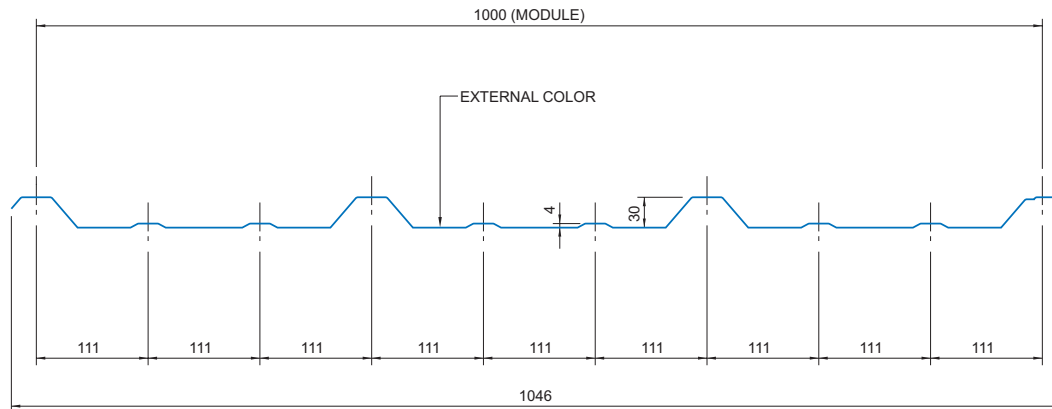

**PROFILE "R" ALUMINUM PANEL**

### Section Properties\*:

Panel Nominal Thickness mm	Weight kg/m <sup>2</sup>	Area cm <sup>2</sup>	Top in Compression				Bottom in Compression				Web Shear & Crippling		
			Ix cm <sup>4</sup>	Sx-Top cm <sup>3</sup>	Sx-Bottom cm <sup>3</sup>	Ma kN.m	Ix cm <sup>4</sup>	Sx-Top cm <sup>3</sup>	Sx-Bottom cm <sup>3</sup>	Ma kN.m	Va kN	Pa kN	
0.70	2.22	8.01	6.48	2.53	10.13	0.24	3.89	2.34	2.34	0.22	5.68		2.78

\*All values are for one meter of panel width.

### Allowable Uniform Loads (kN/m<sup>2</sup>)

Panel Nominal Thickness mm	Number of Spans	Load Case	Span in Meters										
			1.00	1.25	1.50	1.75	2.00	2.25	2.50	2.75	3.00	3.25	3.50
0.70	1	D+L	1.91	0.98	0.56	0.36	0.24	0.17	0.12	0.09	0.07	0.06	0.04
		WP	2.56	1.46	0.85	0.53	0.36	0.25	0.18	0.14	0.11	0.08	0.07
		WS	1.72	0.88	0.51	0.32	0.21	0.15	0.11	0.08	0.06	0.05	0.04
	2	D+L	1.76	1.13	0.78	0.57	0.44	0.35	0.28	0.22	0.17	0.13	0.11
		WP	2.35	1.50	1.04	0.77	0.59	0.46	0.38	0.31	0.26	0.20	0.16
		WS	2.56	1.64	1.14	0.77	0.52	0.36	0.26	0.20	0.15	0.12	0.10
	3	D+L	2.20	1.41	0.98	0.67	0.45	0.32	0.23	0.17	0.13	0.11	0.08
		WP	2.93	1.88	1.30	0.96	0.67	0.47	0.35	0.26	0.20	0.16	0.13
		WS	3.20	1.66	0.96	0.60	0.41	0.28	0.21	0.16	0.12	0.10	0.08

Note : D + L = Dead + Live Load (Deflection limitation: Span/180).  
 WP = Wind Pressure (Deflection limitation: Span/120).  
 WS = Wind Suction (Deflection limitation: Span/120).  
 Material conforming to ALLOY 3003 H26 (Fy = 16.15 kN/cm<sup>2</sup>) or equivalent.

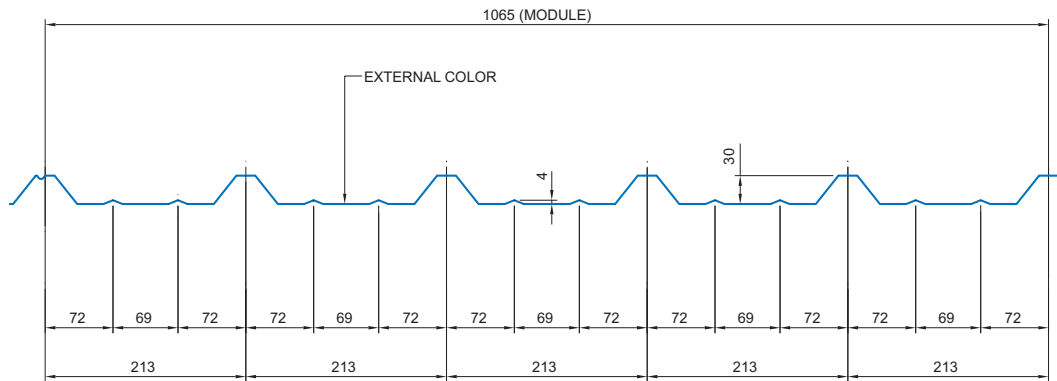

**PROFILE "F" ALUMINUM PANEL**

### Section Properties\*:

Panel Nominal Thickness mm	Weight kg/m <sup>2</sup>	Area cm <sup>2</sup>	Top in Compression				Bottom in Compression				Web Shear & Crippling	
			Ix cm <sup>4</sup>	Sx-Top cm <sup>3</sup>	Sx-Bottom cm <sup>3</sup>	Ma kN.m	Ix cm <sup>4</sup>	Sx-Top cm <sup>3</sup>	Sx-Bottom cm <sup>3</sup>	Ma kN.m	Va kN	Pa kN
0.70	2.33	8.39	7.29	3.42	8.43	0.33	5.36	2.96	3.57	0.28	9.17	4.42

\*All values are for one meter of panel width.

### Allowable Uniform Loads (kN/m<sup>2</sup>)

Panel Nominal Thickness mm	Number of Spans	Load Case	Span in Meters										
			1.00	1.25	1.50	1.75	2.00	2.25	2.50	2.75	3.00	3.25	3.50
0.70	1	D+L	2.14	1.10	0.64	0.40	0.27	0.19	0.14	0.10	0.08	0.07	0.05
		WP	3.21	1.65	0.95	0.60	0.40	0.28	0.21	0.15	0.12	0.10	0.07
		WS	2.36	1.21	0.70	0.44	0.30	0.21	0.15	0.11	0.09	0.07	0.06
	2	D+L	2.24	1.43	1.00	0.73	0.56	0.44	0.33	0.25	0.19	0.16	0.12
		WP	2.99	1.91	1.33	0.98	0.75	0.59	0.48	0.37	0.29	0.24	0.18
		WS	3.52	2.25	1.56	1.06	0.71	0.50	0.36	0.27	0.21	0.17	0.13
	3	D+L	2.80	1.79	1.20	0.75	0.51	0.36	0.26	0.19	0.15	0.13	0.09
		WP	3.73	2.39	1.66	1.13	0.76	0.53	0.39	0.29	0.22	0.19	0.14
		WS	4.40	2.29	1.32	0.83	0.56	0.39	0.29	0.21	0.17	0.13	0.10

Note : D + L = Dead + Live Load (Deflection limitation: Span/180).  
 WP = Wind Pressure (Deflection limitation: Span/120).  
 WS = Wind Suction (Deflection limitation: Span/120).  
 Material conforming to ALLOY 3003 H26 (Fy = 16.15 kN/cm<sup>2</sup>) or equivalent.

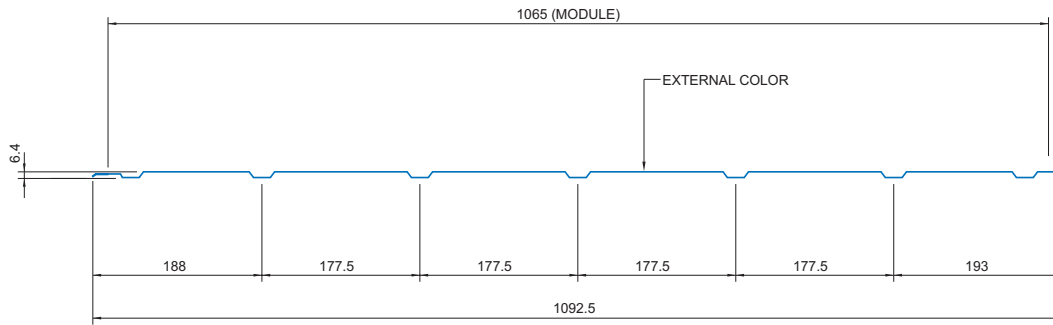

**PROFILE "C" ALUMINUM PANEL**

### Section Properties\*:

Panel Nominal Thickness mm	Weight kg/m <sup>2</sup>	Area cm <sup>2</sup>	Top in Compression				Bottom in Compression				Web Shear & Crippling		
			Ix cm <sup>4</sup>	Sx-Top cm <sup>3</sup>	Sx-Bottom cm <sup>3</sup>	Ma kN.m	Ix cm <sup>4</sup>	Sx-Top cm <sup>3</sup>	Sx-Bottom cm <sup>3</sup>	Ma kN.m	Va kN	Pa kN	
0.70	2.09	7.51	0.22	0.49	0.82	0.05	0.28	0.52	3.00	0.05	2.95		5.70

\*All values are for one meter of panel width.

### Allowable Uniform Loads (kN/m<sup>2</sup>)

Panel Nominal Thickness mm	Number of Spans	Load Case	Span in Meters											
			1.00	1.25	1.50	1.75	2.00	2.25	2.50	2.75	3.00	3.25	3.50	
0.70	1	D+L	0.06	0.03	0.02	0.01	0.01	0.01	0.00	0.00	0.00	0.00	0.00	0.00
		WP	0.10	0.05	0.03	0.02	0.01	0.01	0.01	0.00	0.00	0.00	0.00	0.00
		WS	0.12	0.06	0.04	0.02	0.02	0.01	0.01	0.01	0.00	0.00	0.00	0.00
	2	D+L	0.16	0.08	0.05	0.03	0.02	0.01	0.01	0.01	0.01	0.00	0.00	0.00
		WP	0.23	0.12	0.07	0.04	0.03	0.02	0.01	0.01	0.01	0.01	0.01	0.01
		WS	0.30	0.15	0.09	0.06	0.04	0.03	0.02	0.01	0.01	0.01	0.01	0.01
	3	D+L	0.12	0.06	0.04	0.02	0.02	0.01	0.01	0.01	0.00	0.00	0.00	0.00
		WP	0.18	0.09	0.05	0.03	0.02	0.02	0.01	0.01	0.01	0.01	0.01	0.00
		WS	0.23	0.12	0.07	0.04	0.03	0.02	0.01	0.01	0.01	0.01	0.01	0.01

Note : D + L = Dead + Live Load (Deflection limitation: Span/180).  
 WP = Wind Pressure (Deflection limitation: Span/120).  
 WS = Wind Suction (Deflection limitation: Span/120).  
 Material conforming to ALLOY 3003 H26 (Fy = 16.15 kN/cm<sup>2</sup>) or equivalent.

Exterior single skin panels are used on the roofs and walls of structures to provide a protective outer shell.

Zamil Steel offers three different profile options for single skin roof and wall panels. They are: Profile “B”, Profile “R” and Profile “A”.

The choice of the profile is primarily dependent on aesthetic preference, economy and the level of expertise of the erection crew. Since all these panels use the same raw material coil width, a panel with more ribs or deeper ribs will generally have a narrower width (coverage area), a higher load capacity and a higher price.

The standard Zamil Steel roof and wall panel profiles have been selected on the basis of optimizing value without sacrificing function. Optional panels are also available and are viable in some applications and situations.

Zamil Steel roof and wall panels are available in all standard panel colors. Standard and optional roof and wall single skin panel profiles and their respective available colors are noted in the following table.

The properties of these panels can be found in **section 8.5**.



Panel Location	Standard		Optional	
	Panel Profile	Finish Color	Panel Profile	Finish Color
Roof Panel	“B”	Zincalume	“A”	All standard colors
Wall Panel	“R”	All standard colors	“A” or “B”	All standard colors

# CHAPTER 8 : SINGLE SKIN PANELS

## Section 8.8 : Exterior Roof & Wall Panel Details

2 of 4

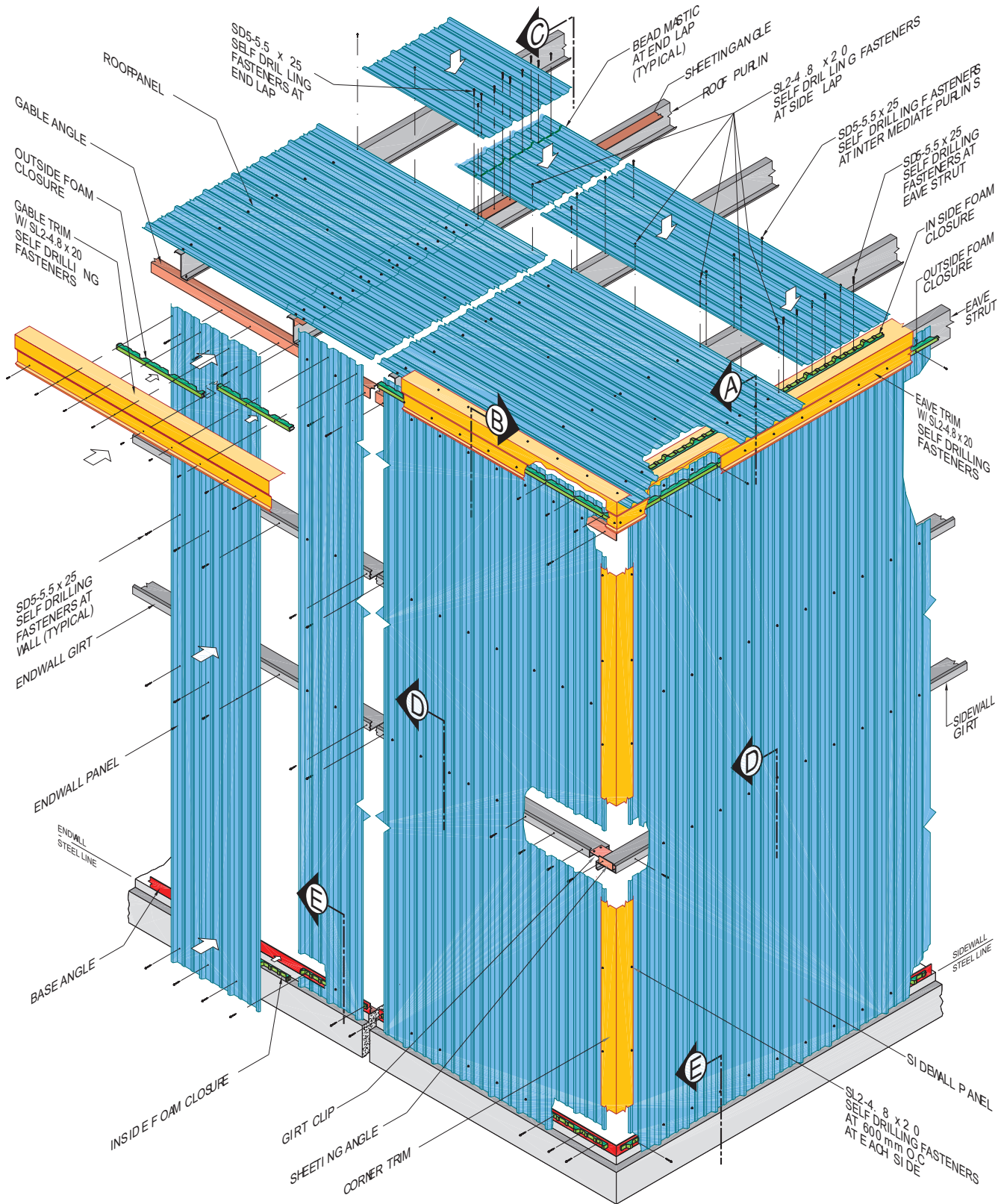

**ISOMETRIC** : PANELS AT ROOF AND WALLS OF A FULLY SHEETED BUILDING

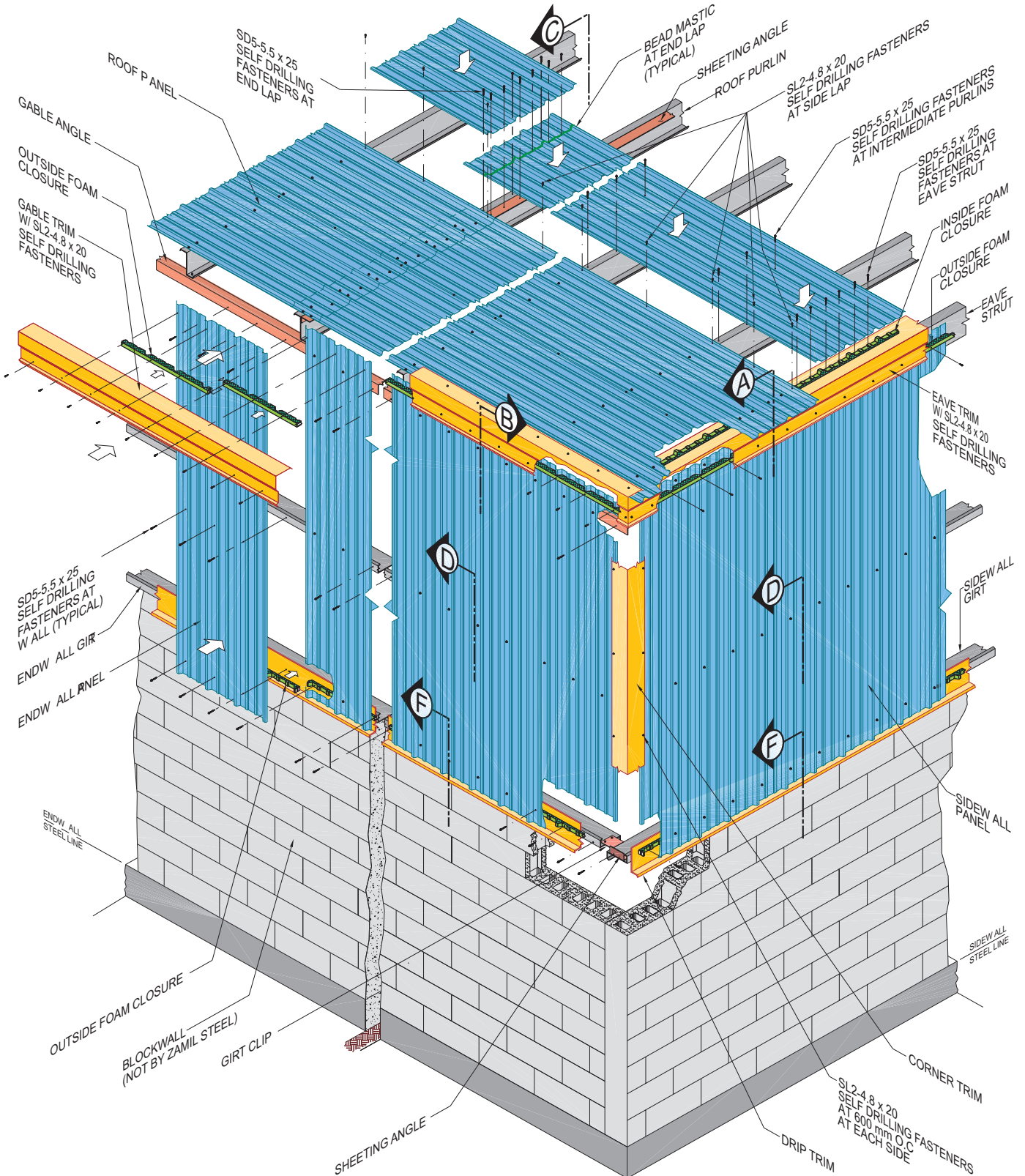

(ISOMETRIC) : PANELS AT ROOF AND WALLS OF A PARTIALLY SHEETED BUILDING WITH BLOCK WALLS



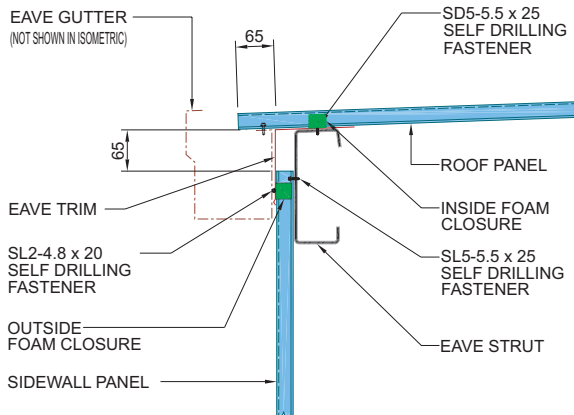

**SECTION-A** : ROOF AND WALL PANEL AT EAVE

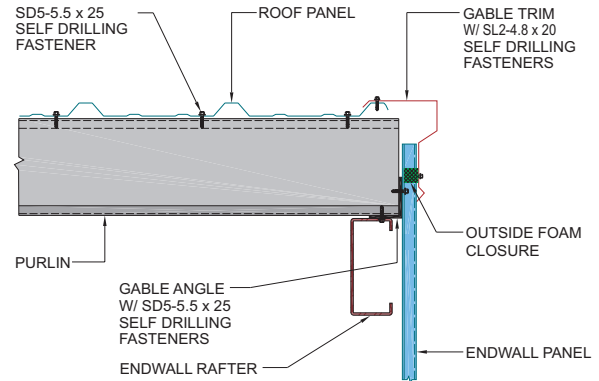

**SECTION-B** : ROOF AND WALL PANEL AT GABLE

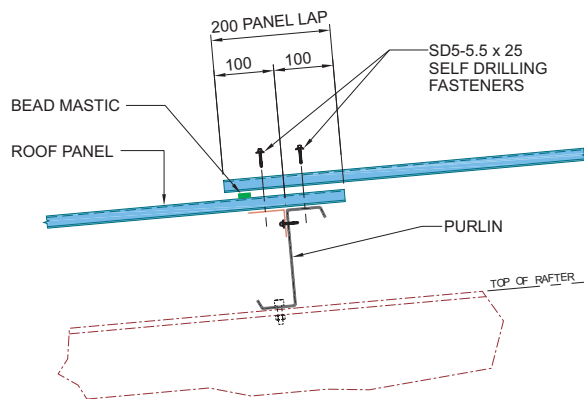

**SECTION-C** : ROOF PANEL AT PURLIN (ENDLAP)

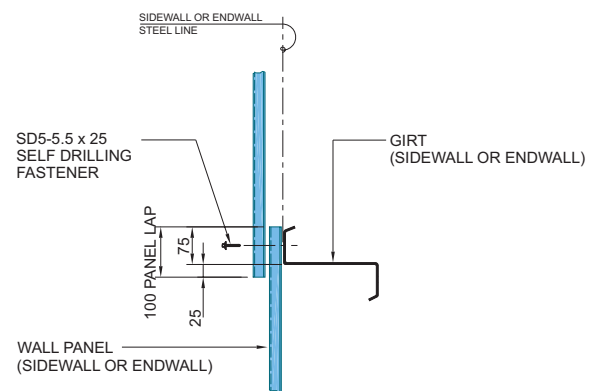

**SECTION-D** : WALL PANEL AT GIRTS (ENDLAP)

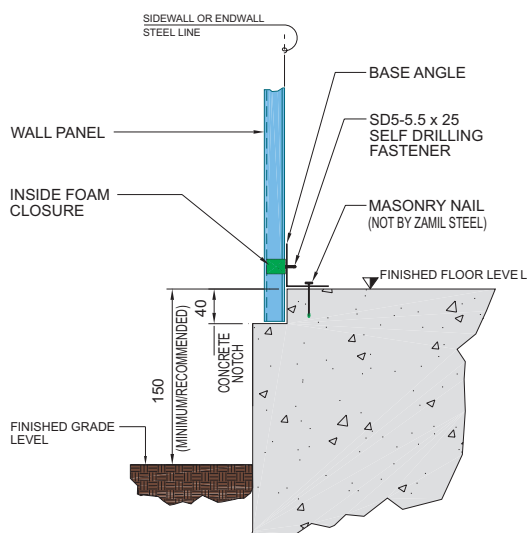

**SECTION-E** : WALL PANEL AT BASE

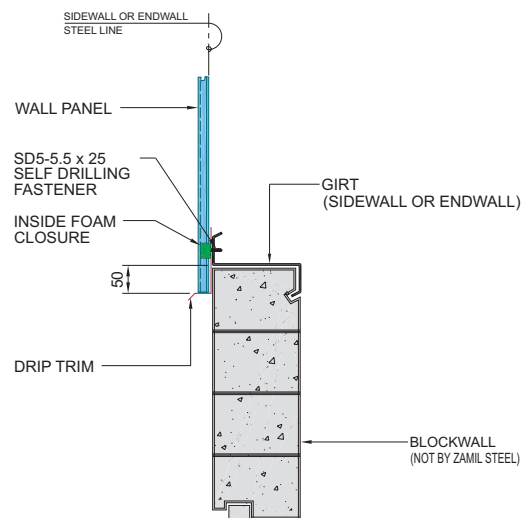

**SECTION-F** : WALL PANEL ABOVE BLOCKWALL

**Liner** panels are used to conceal the roof purlins, wall girts and fiberglass insulation on the inside of roofs and walls of pre-engineered buildings where a neat and smooth finished appearance is desired.

The standard Zamil Steel liner is a Profile “R” panel, which is the most economical and most popular panel especially for use in factories, warehouses, aircraft hangars, and general industrial buildings.

Optional liners include Zamil Steel’s Profile “B”, Profile “A”, Profile “D” and Profile “E” panels which are available upon request.

The table below summarizes the properties of these standard liner panels.

Also available as a standard offer is 0.7 mm thick bare marine aluminum panels and Environ pre-painted aluminum panels in Frost White color only.



Description	Steel Liner Panel			
	Profile “R”	Profile “B”	Profile “A”	Profiles “D”&“E”
<b>Material Thickness (mm)</b>	0.5	0.5	0.5	0.5
<b>Base Metal</b>	Zincalume	Zincalume	Zincalume	Zincalume
<b>Paint Coating</b>	XRW	XRW	XRW	XRW
<b>Panel Width (mm)</b>	1000	960	900	300
<b>Maximum Length(mm)</b>	9000	9000	9000	9000
<b>Available Colors</b>	All standard colors	All standard colors	All standard colors	All standard colors

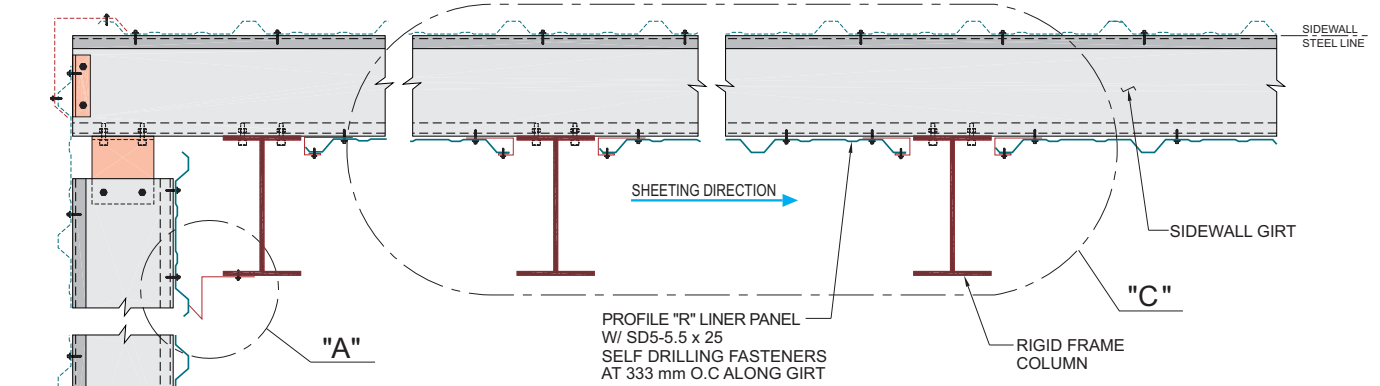

**PLAN** : PROFILE "R" LINER PANEL DETAILS WITH RIGID FRAME AT ENDWALL

[EXTERIOR WALL PANELS ARE SHOWN IN BROKEN LINES]

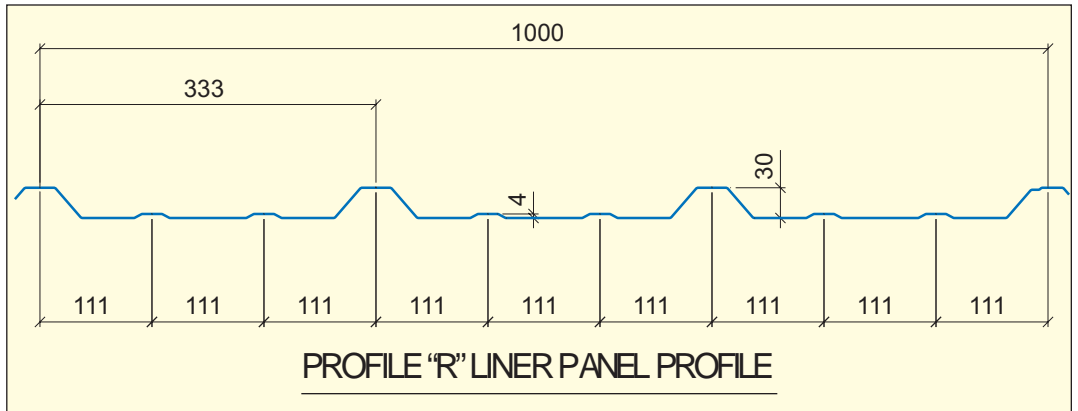
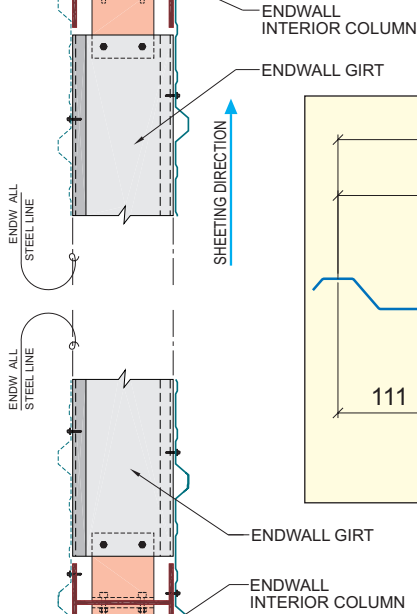

**PLAN** : PROFILE "R" LINER PANEL DETAILS WITH P & B AT ENDWALL

[EXTERIOR WALL PANELS ARE SHOWN IN BROKEN LINES]

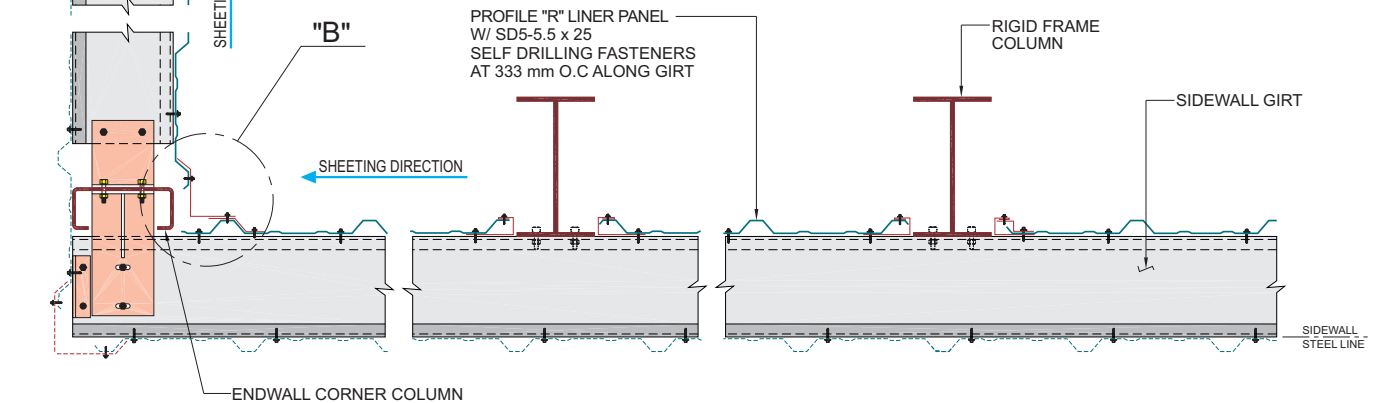

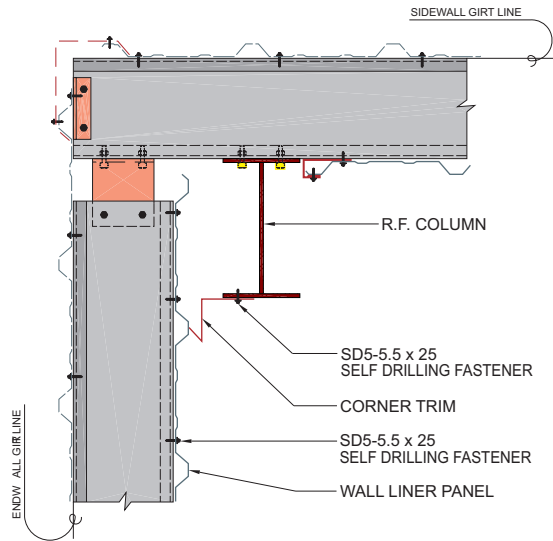

DETAIL-A : LINER AT CORNER (R.F. END)

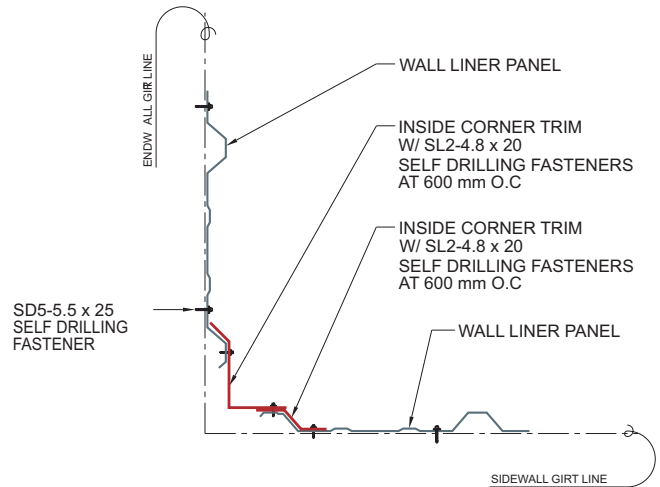

DETAIL-B : LINER AT CORNER (P&B END)

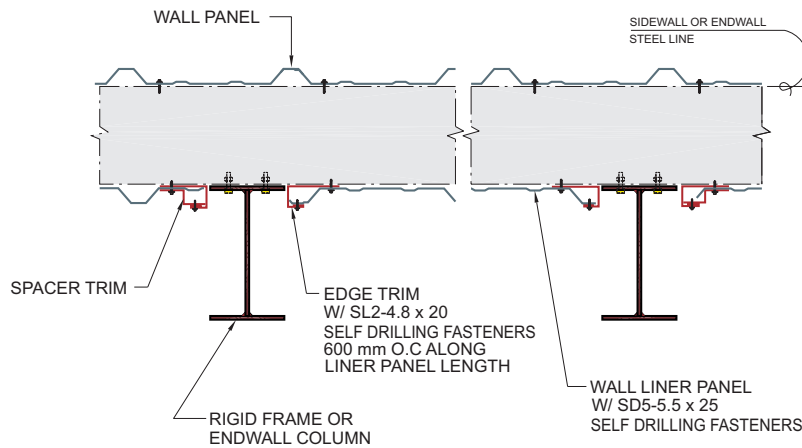

DETAIL-C : LINER AT WALLS WITH BY-PASS GIRTS

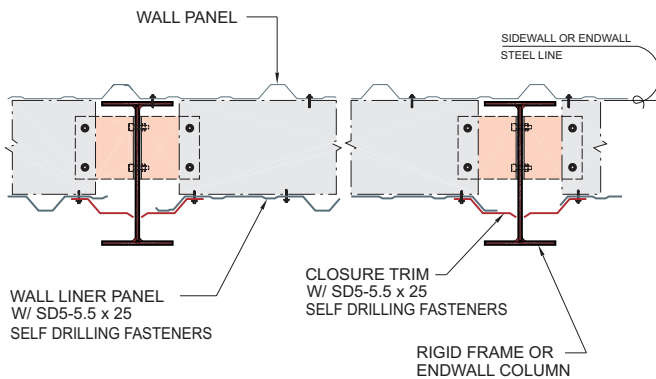

NOTE: RIGID FRAME OR ENDWALL COLUMN DEPTH ARE MORE THAN 200 mm

DETAIL: LINER AT WALLS WITH FLUSH GIRTS

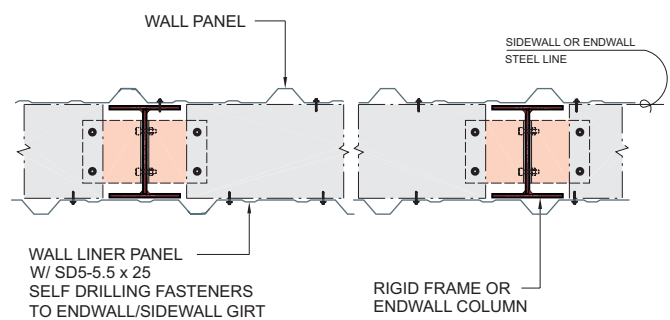

NOTE: RIGID FRAME OR ENDWALL COLUMN DEPTH ARE NOT MORE THAN 200 mm

DETAIL: LINER AT WALLS WITH FLUSH GIRTS

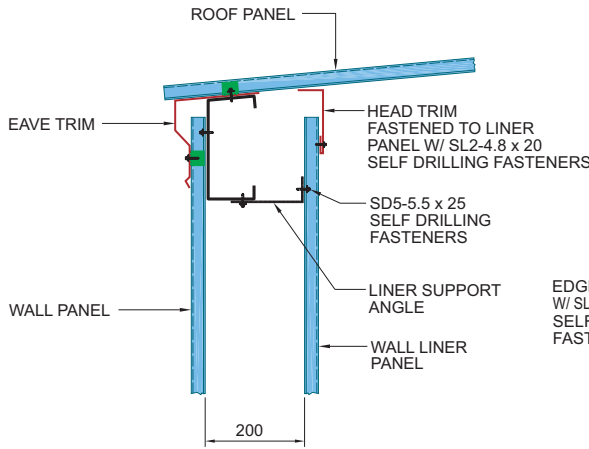

**DETAIL : LINER AT FULL HEIGHT OF WALL**

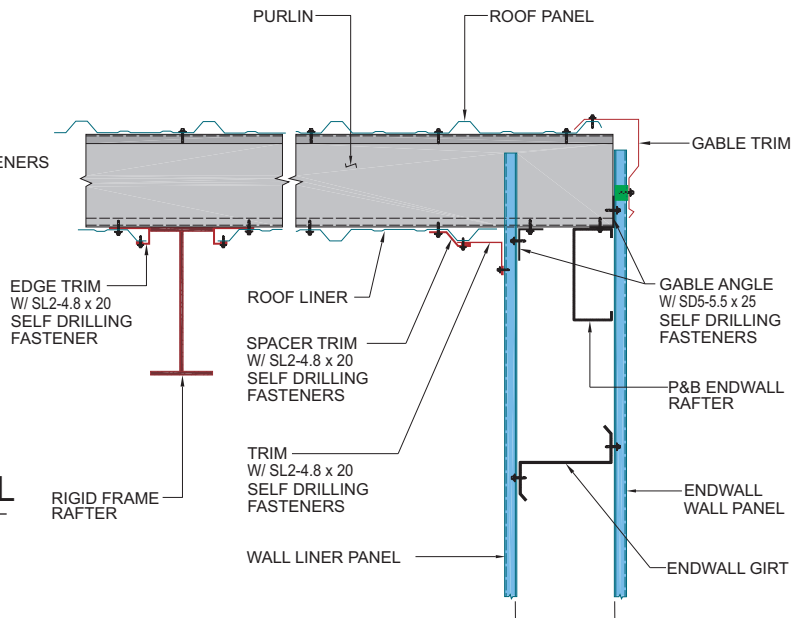

**DETAIL : ROOF AND WALL LINER AT GABLE**

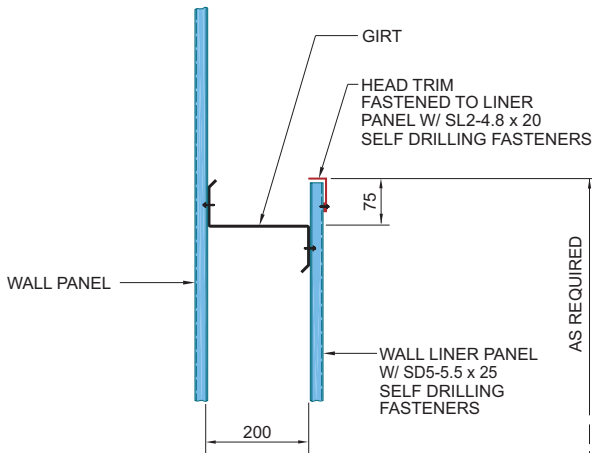

**DETAIL : LINER NOT AT FULL HEIGHT OF WALL**

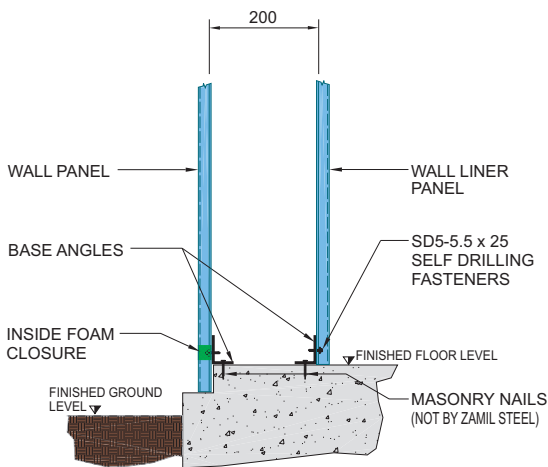

**DETAIL : WALL LINER AT BASE**

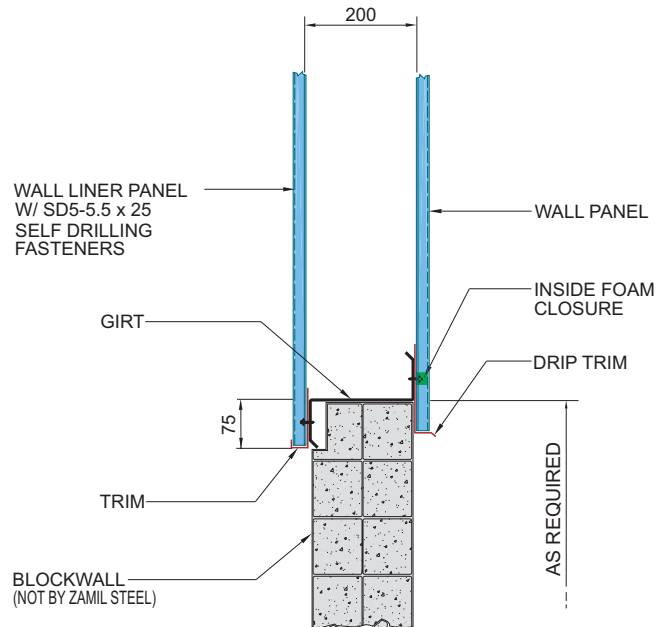

**DETAIL : LINER AT WALL WITH BLOCKWALL**

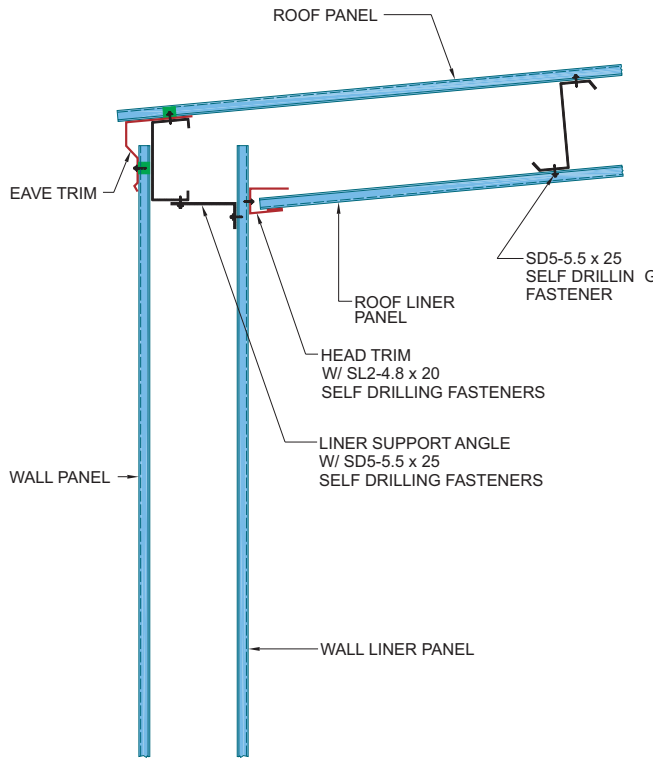

**DETAIL**: ROOF AND WALL LINER AT EAVE

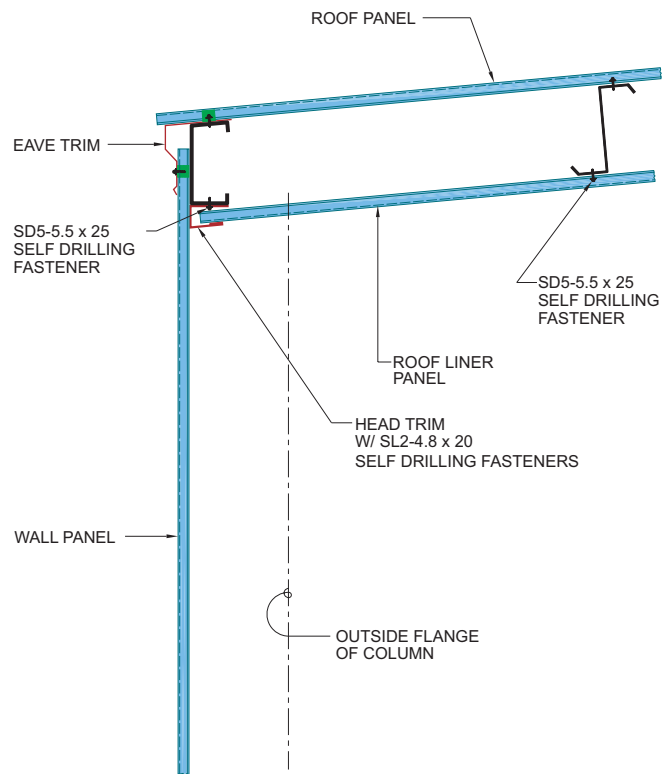

**DETAIL**: LINER AT ROOF ONLY

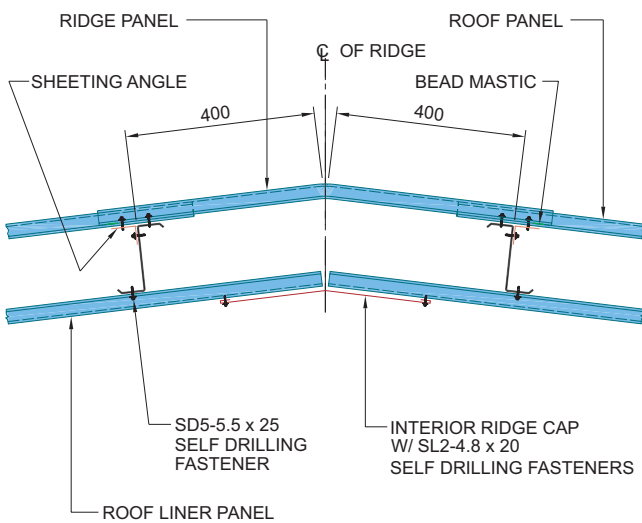

**DETAIL**: ROOF LINER AT RIDGE

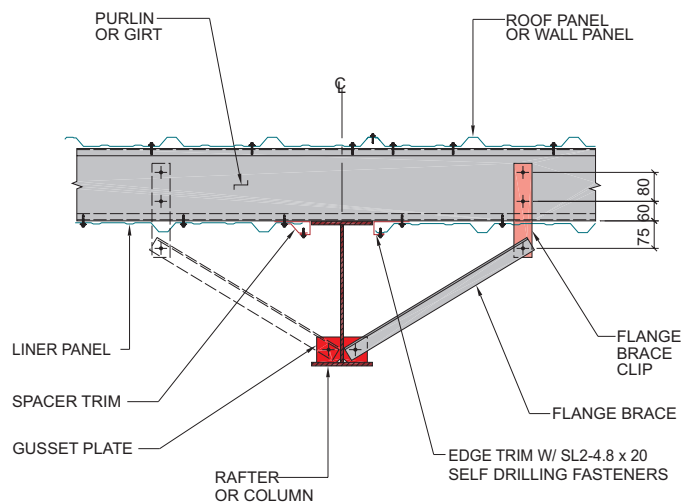

**DETAIL**: LINER AT ROOF OR WALL W/ FLANGE BRACE

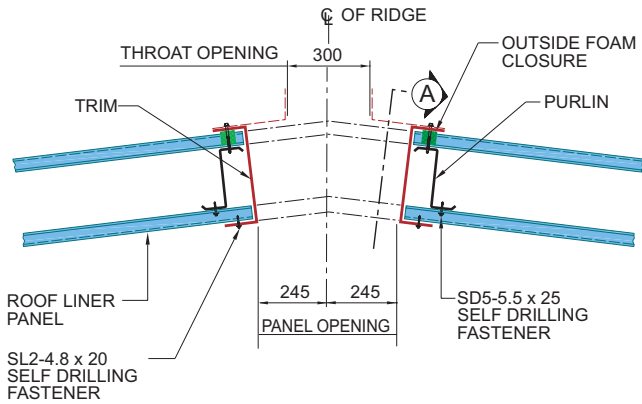

**SECTION-A**

**DETAIL : ROOF LINER AT RIDGE VENT**

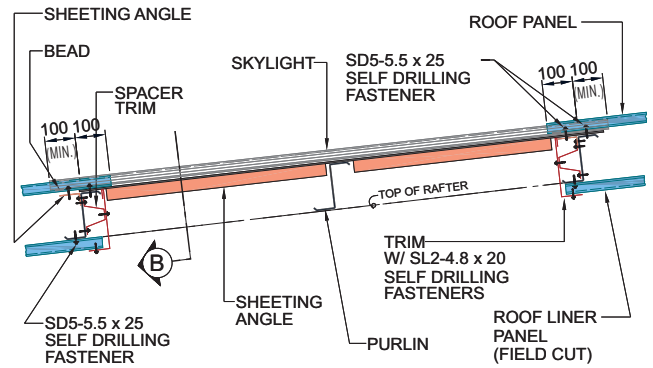

**SECTION-B**

**DETAIL : ROOF LINER AT SKYLIGHT**

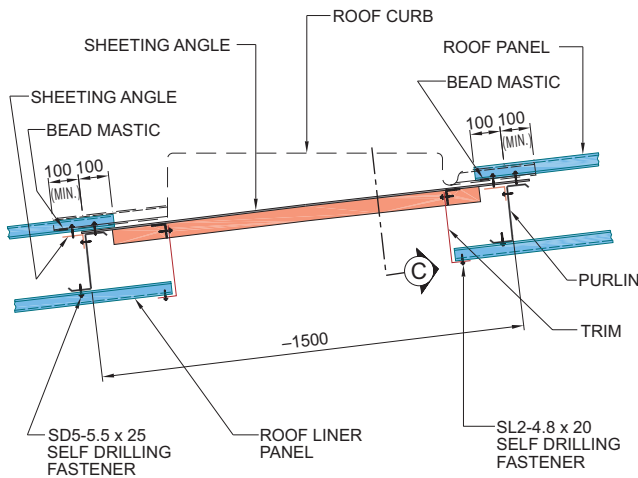
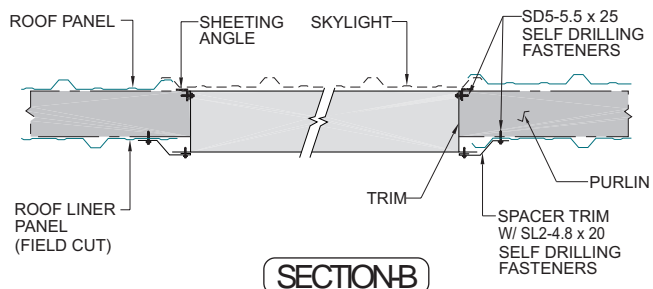
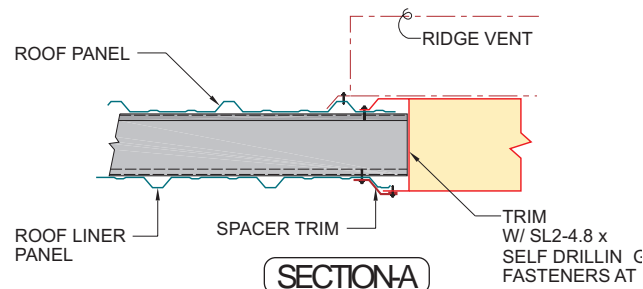

**SECTION-C**

**DETAIL : ROOF LINER AT ROOF CURB**

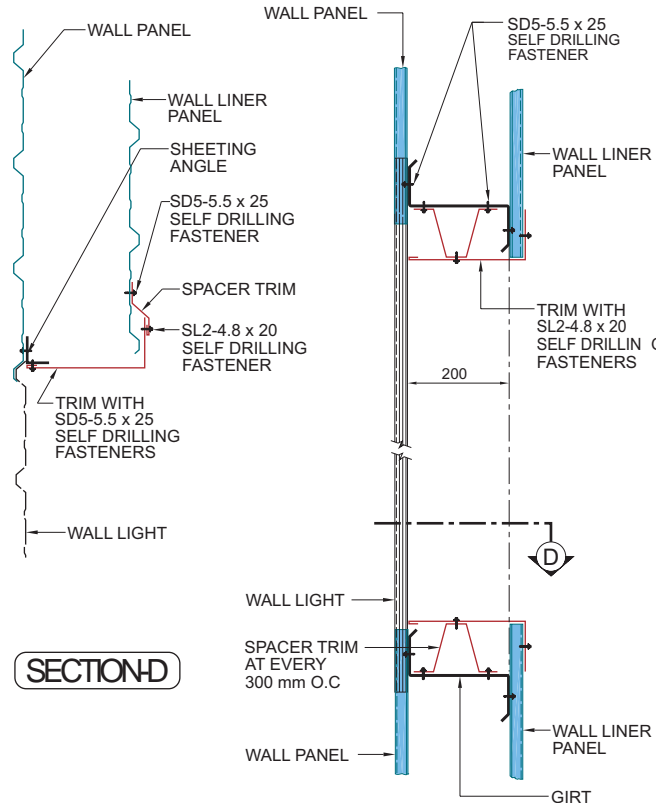

**SECTION-D**

**DETAIL : WALL LINER AT WALL LIGHT**

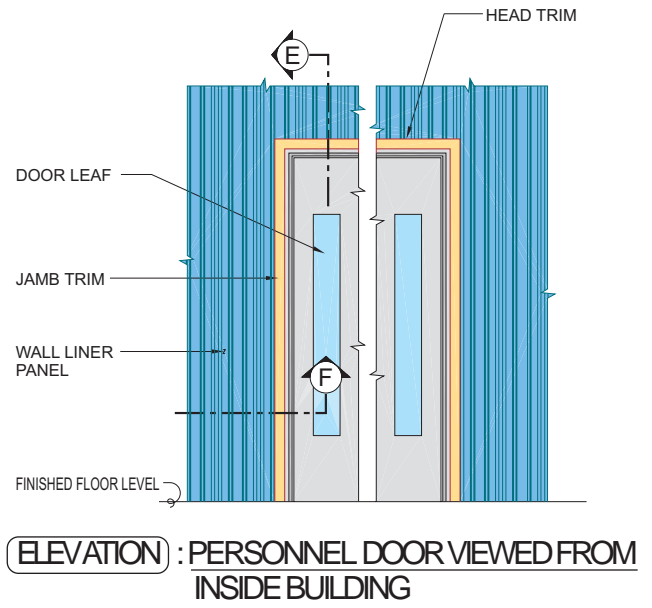
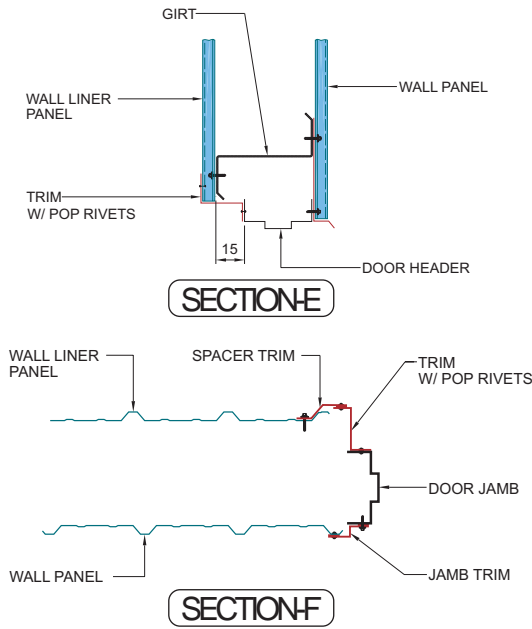

DETAIL : LINER AT WALL WITH PERSONNEL DOOR

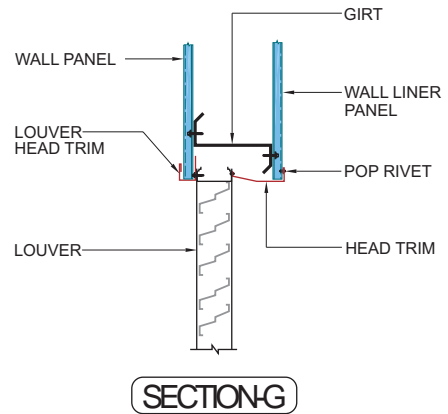
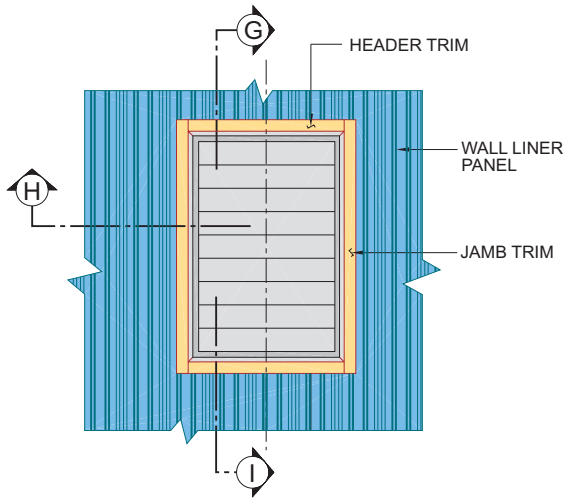

ELEVATION : LOUVER VIEWED FROM INSIDE BUILDING

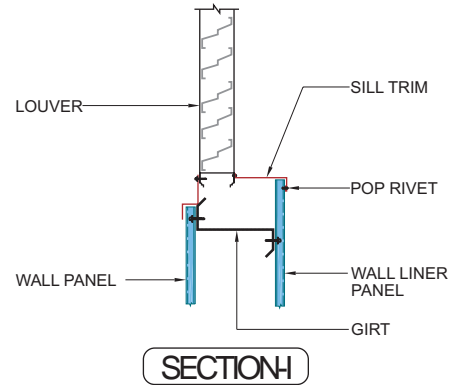
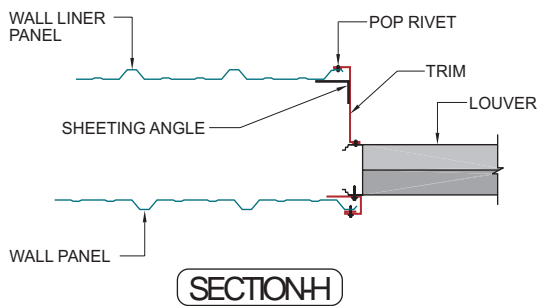

DETAIL : LINER AT WALL WITH LOUVER



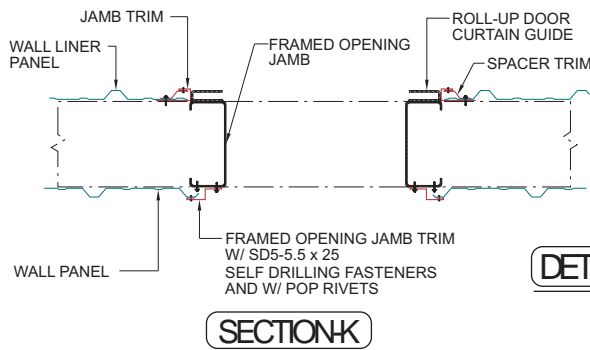
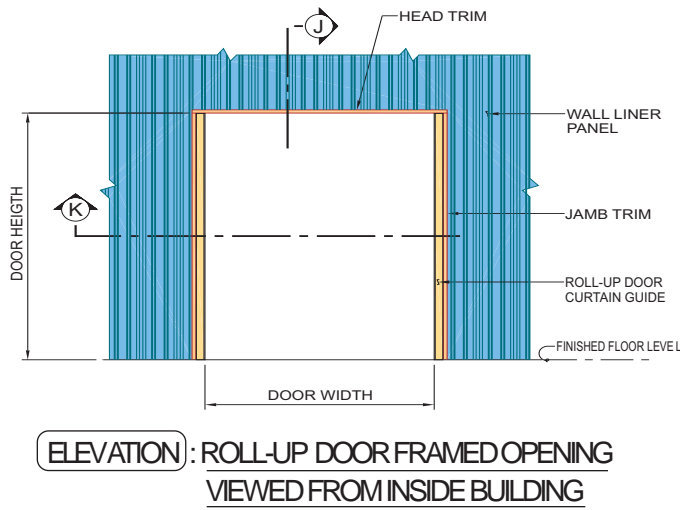
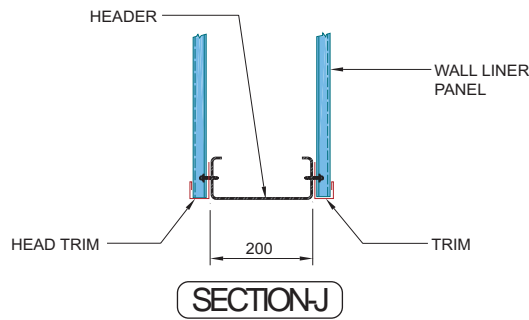

**DETAIL : LINER AT WALL WITH ROLL-UP DOOR**

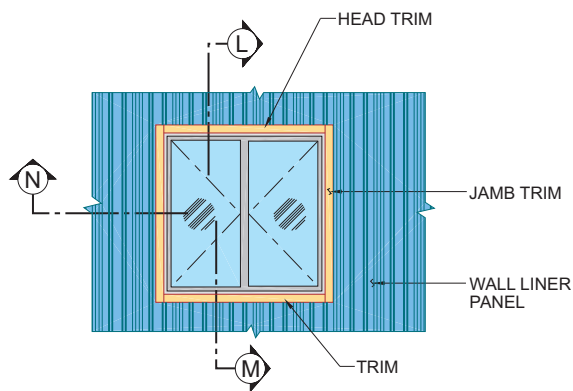

**ELEVATION : WINDOW VIEWED FROM INSIDE BUILDING**

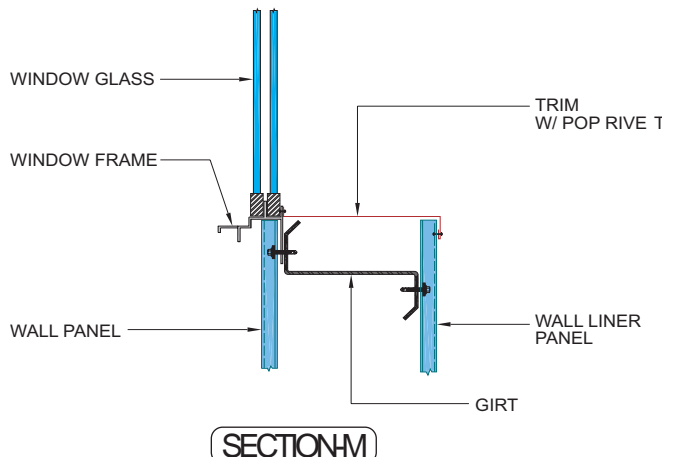
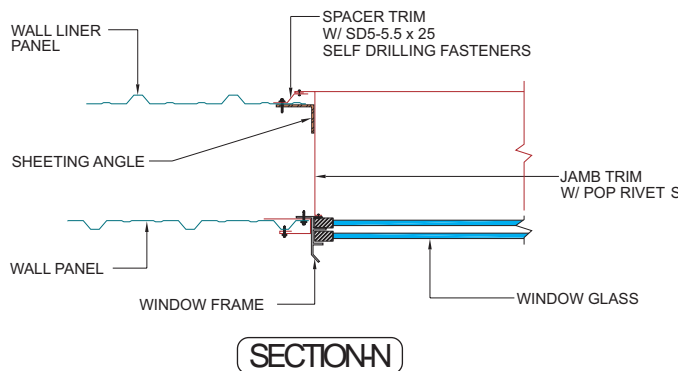
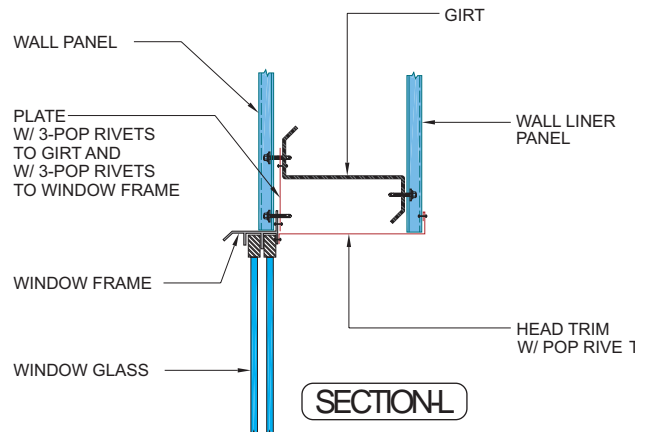

**DETAIL : LINER AT WALL WITH WINDOW**

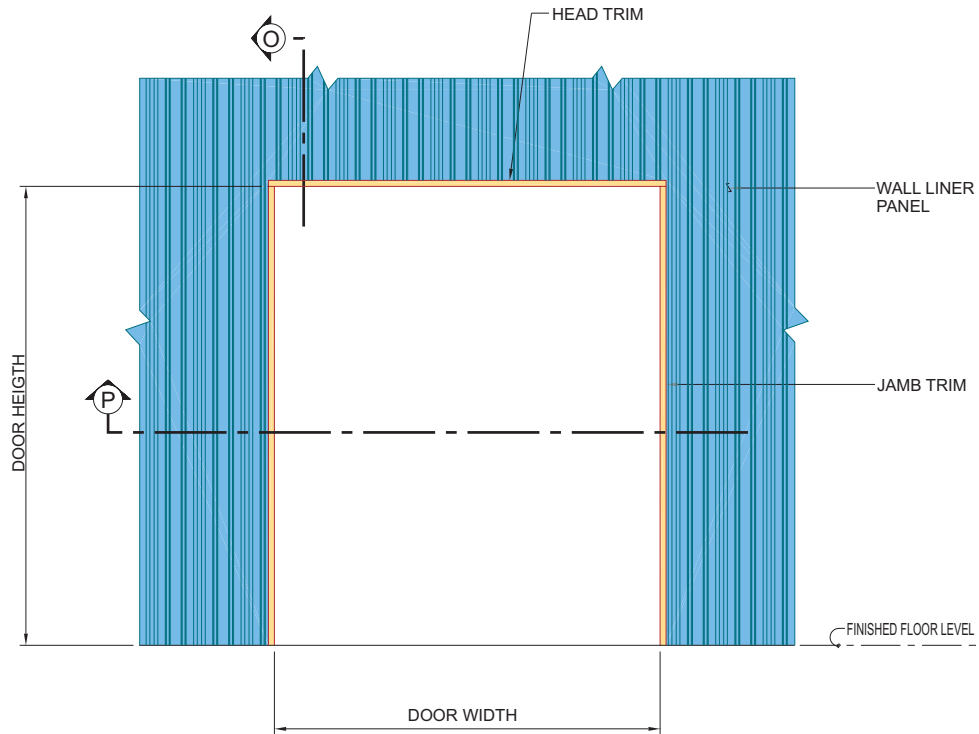

**ELEVATION** : SLIDING DOOR FRAMED OPENING VIEWED FROM INSIDE BUILDING

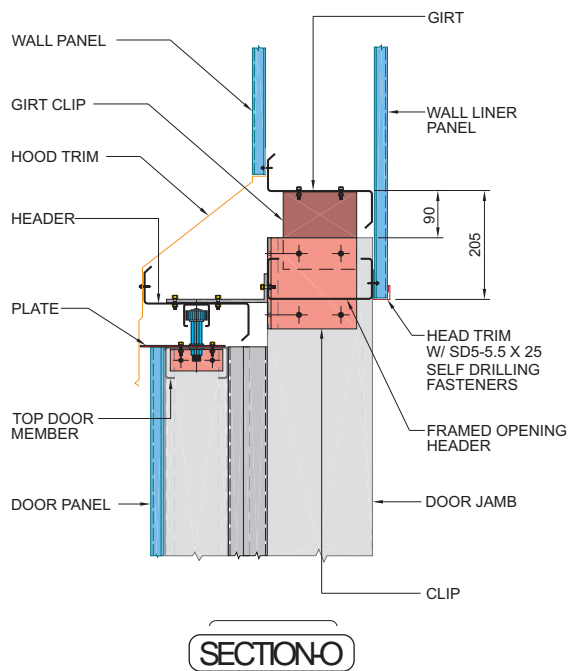

**SECTION O-O**

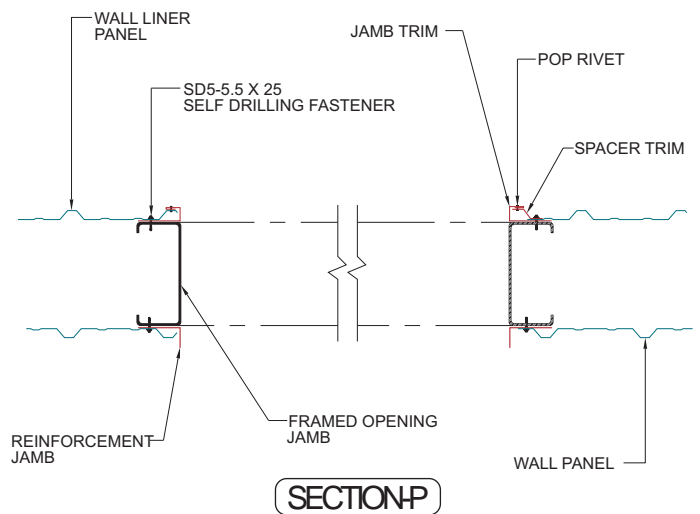

**SECTION P-P**

**DETAIL** : LINER AT WALL WITH SLIDING DOOR

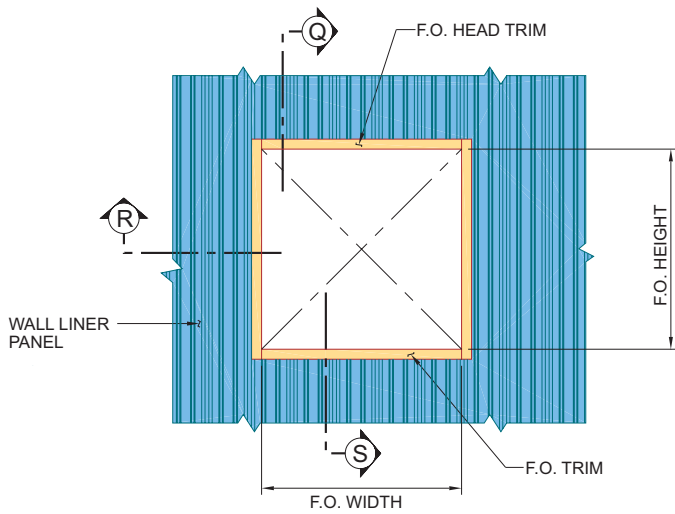

**ELEVATION**: FRAMED OPENING VIEWED FROM INSIDE BUILDING

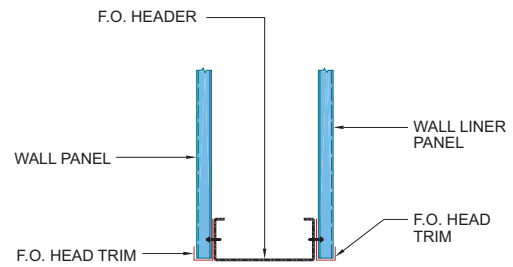

**SECTION Q-Q**

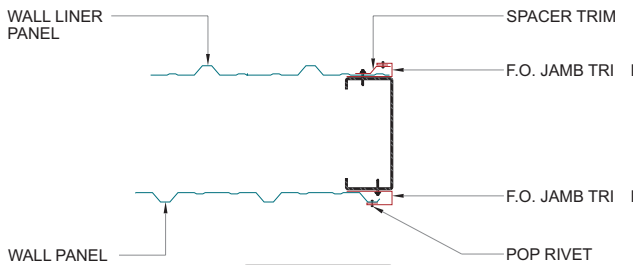

**SECTION R-R**

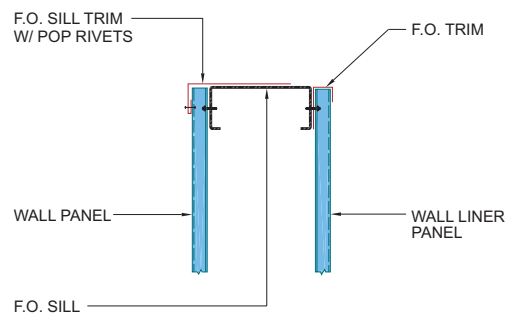

**SECTION S-S**

**DETAIL**: LINER AT WALL WITH FRAMED OPENING

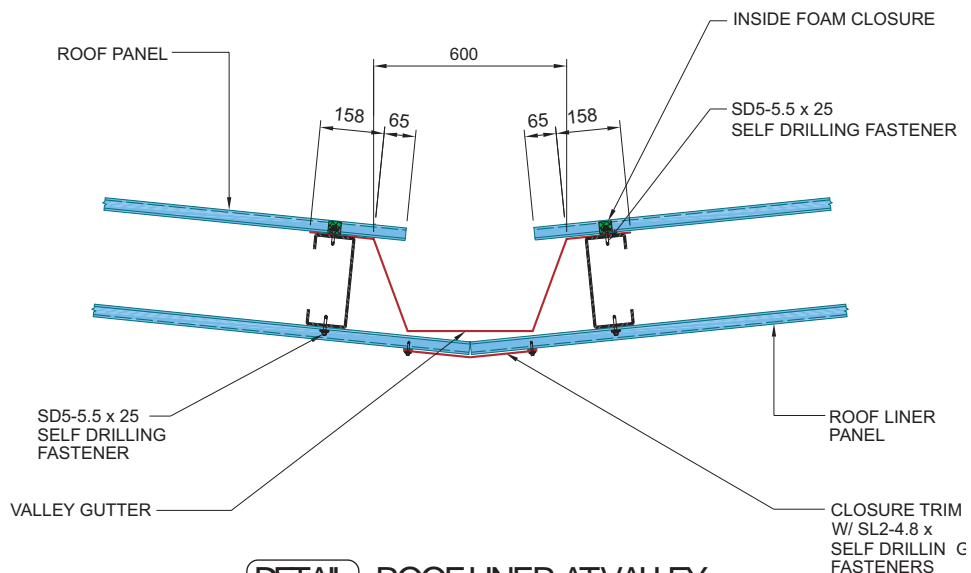

**DETAIL**: ROOF LINER AT VALLEY

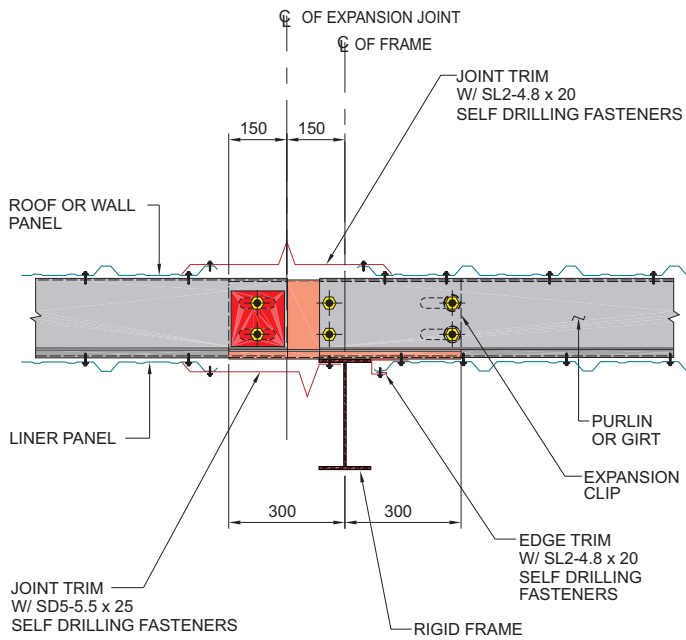

**DETAIL** : ROOF/WALL LINER AT EXPANSION JOINT

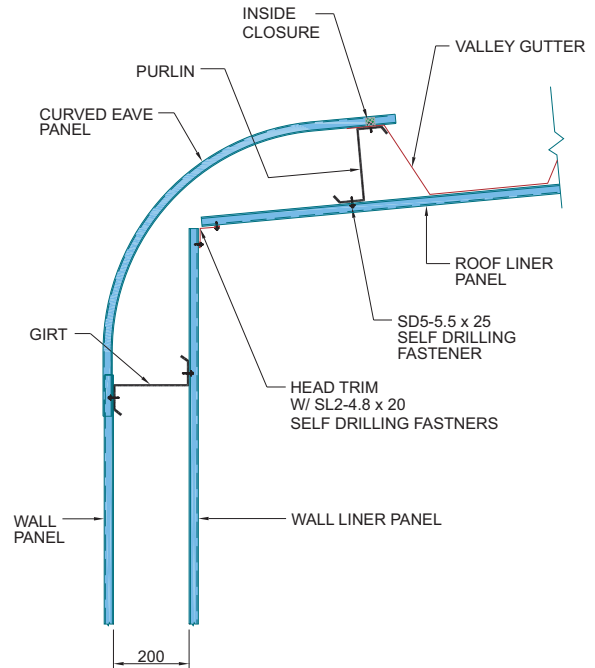

**DETAIL** : ROOF & WALL LINER AT CURVED EAVE

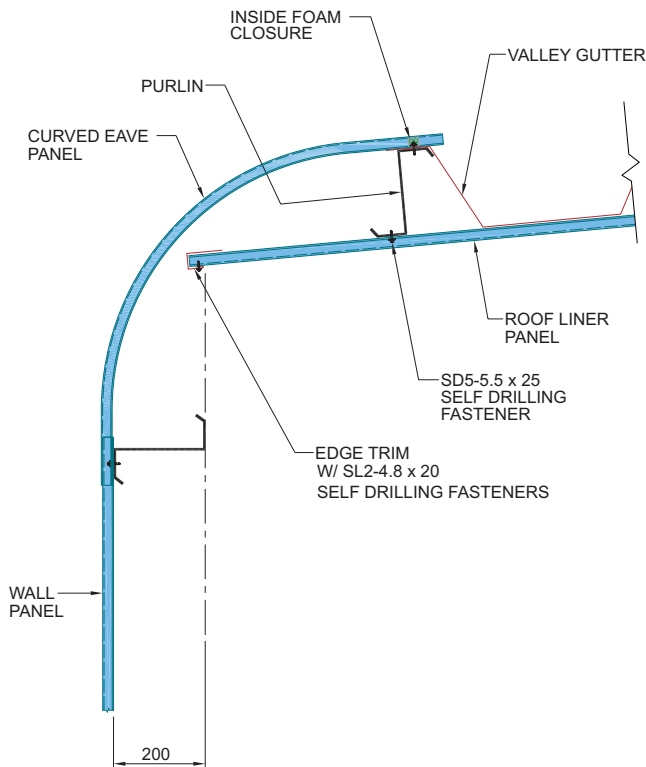

**DETAIL** : ROOF LINER AT CURVED EAVE

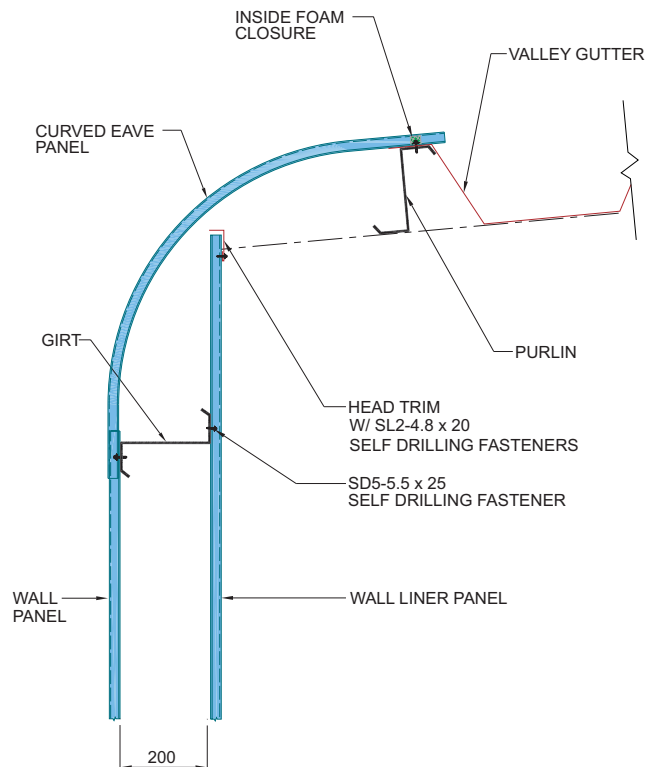

**DETAIL** : WALL LINER AT CURVED EAVE

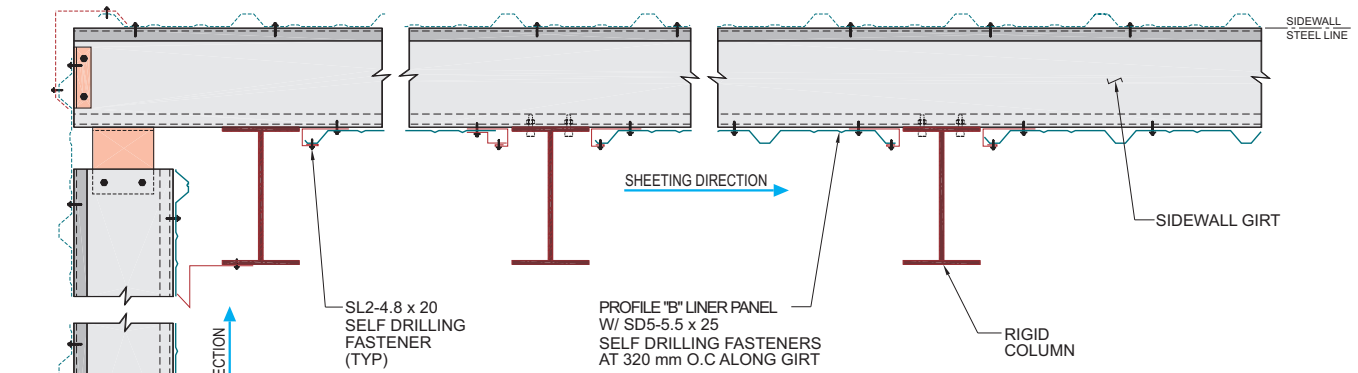

**PLAN** : PROFILE "B" LINER PANEL DETAILS WITH RIGID FRAME AT ENDWALL

[EXTERIOR WALL PANELS ARE SHOWN IN BROKEN LINES]

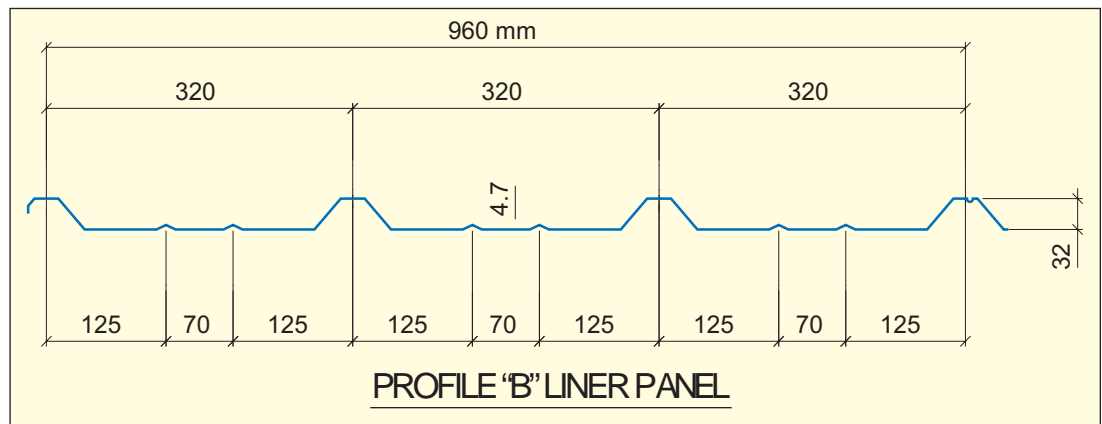
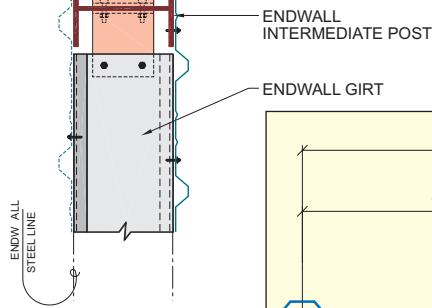

**PROFILE "B" LINER PANEL**

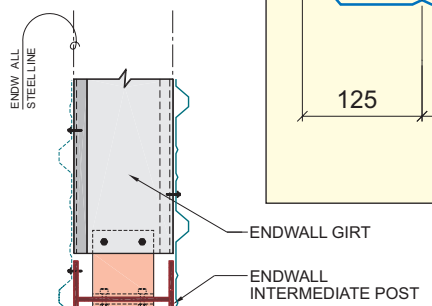

**PLAN** : PROFILE "B" LINER PANEL DETAILS WITH P & B AT ENDWALL

[EXTERIOR WALL PANELS ARE SHOWN IN BROKEN LINES]

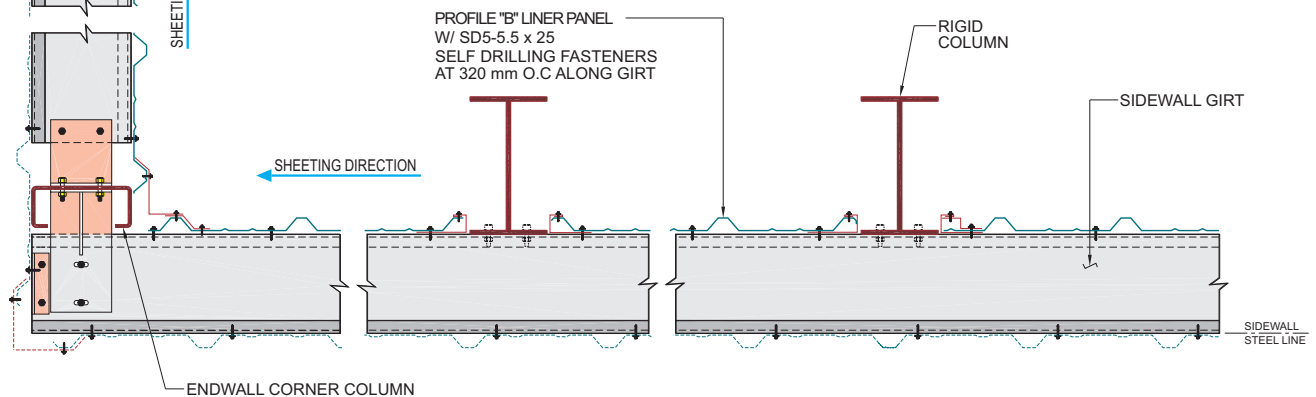

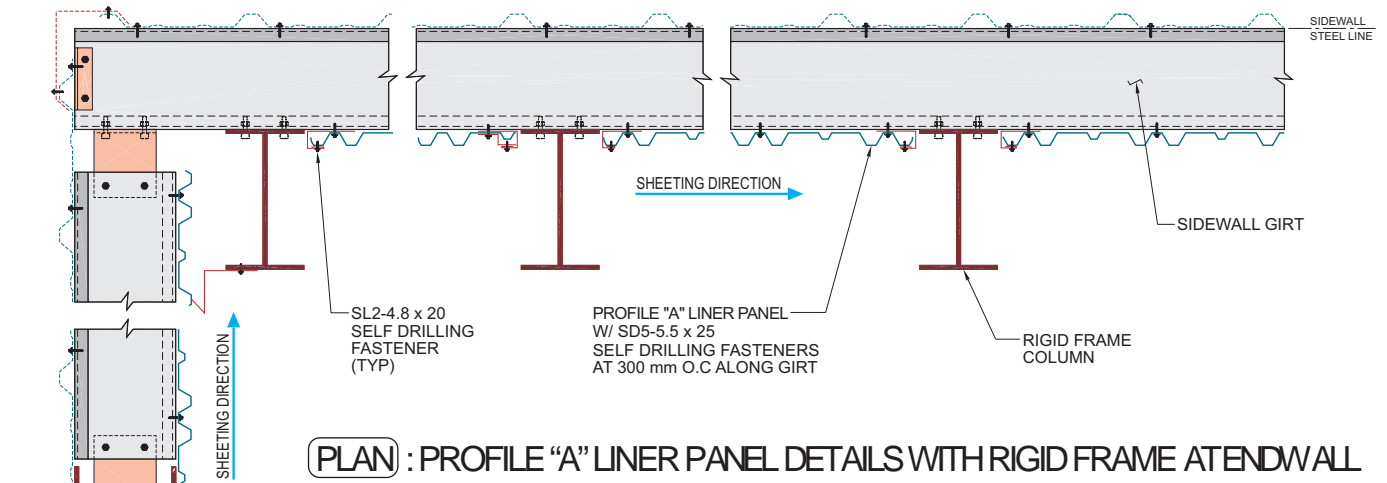

[EXTERIOR WALL PANELS ARE SHOWN IN BROKEN LINES]

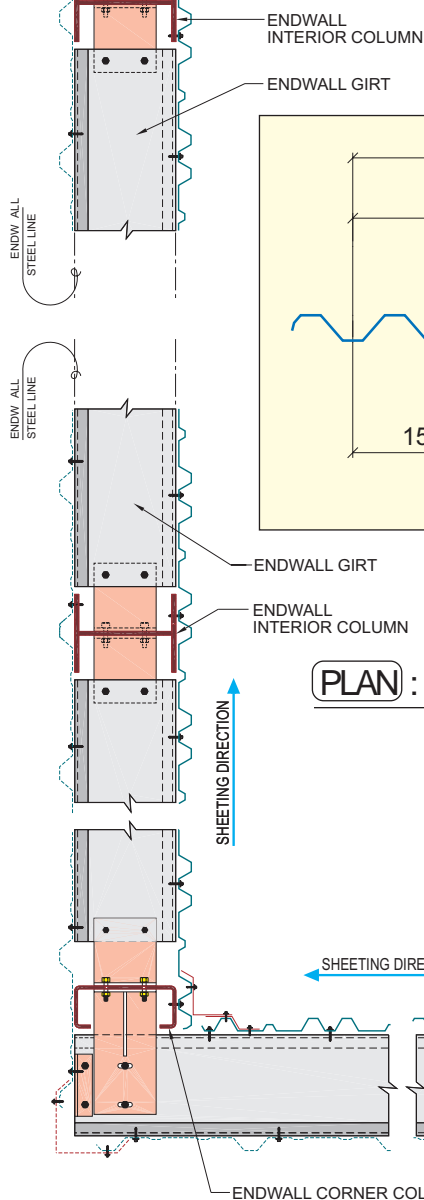
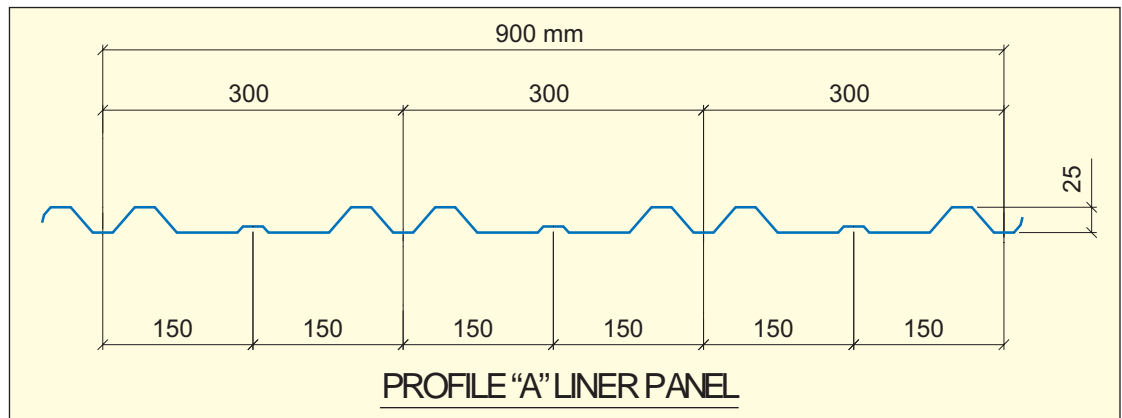

[EXTERIOR WALL PANELS ARE SHOWN IN BROKEN LINES]

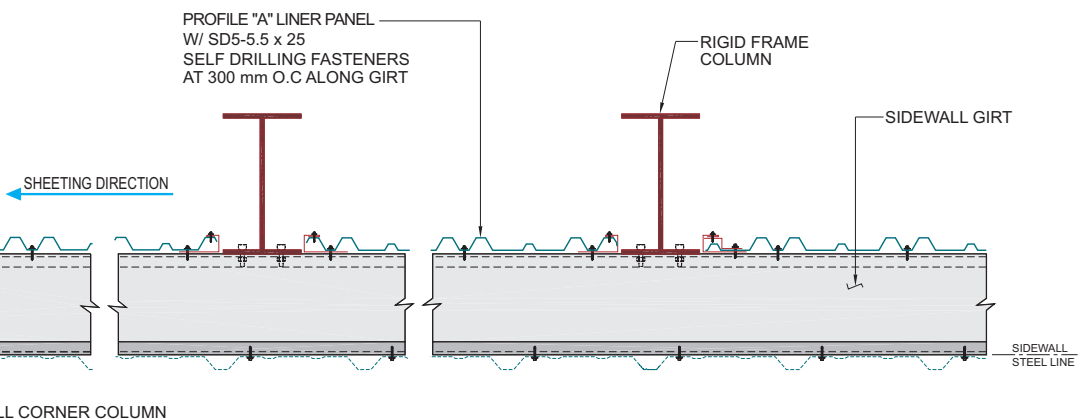

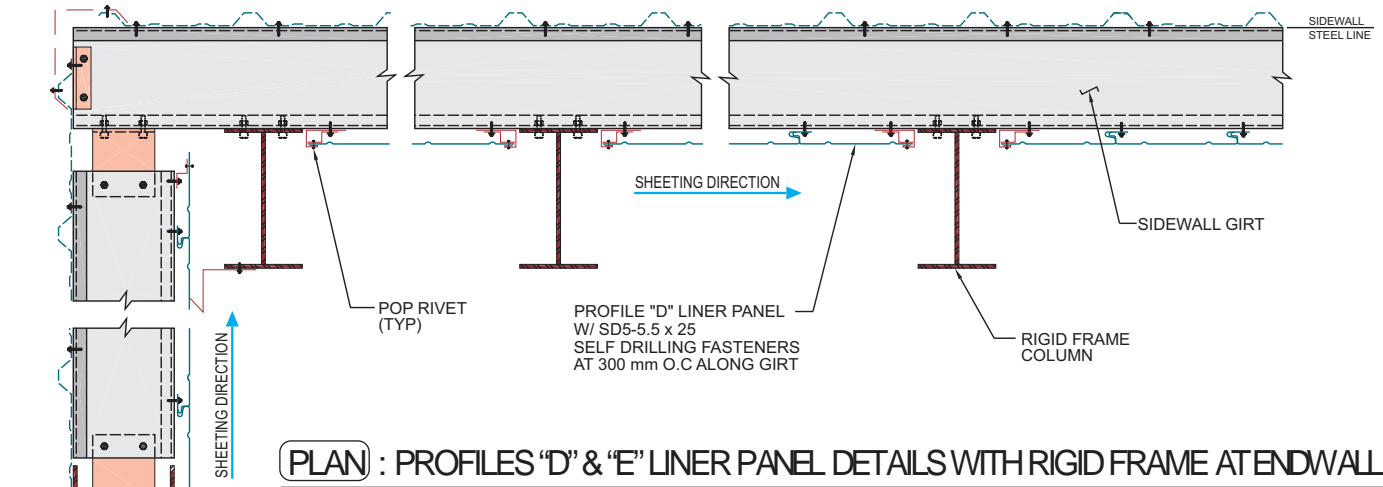

**PLAN** : PROFILES "D" & "E" LINER PANEL DETAILS WITH RIGID FRAME AT ENDWALL

(DETAILS FOR PROFILE "E" LINER PANELS ARE SIMILAR TO PROFILE "D" LINER PANELS AS SHOWN)  
[EXTERIOR WALL PANELS ARE SHOWN IN BROKEN LINES]

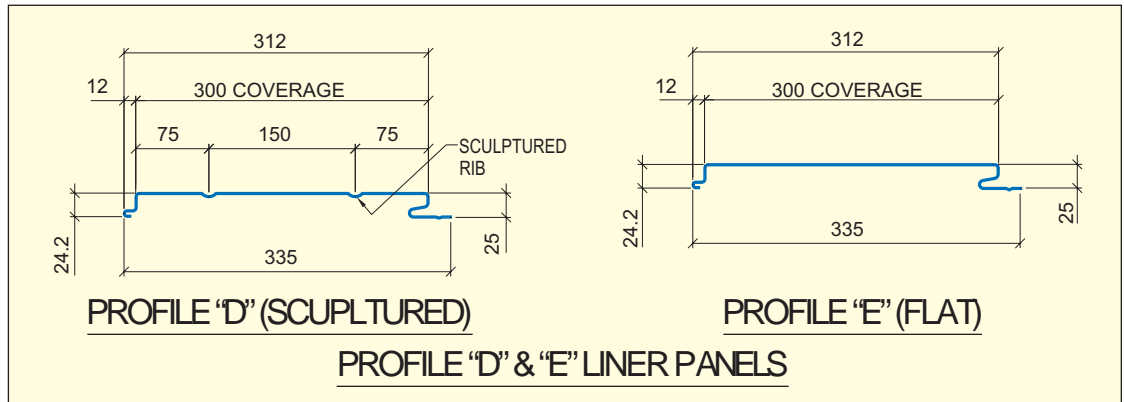
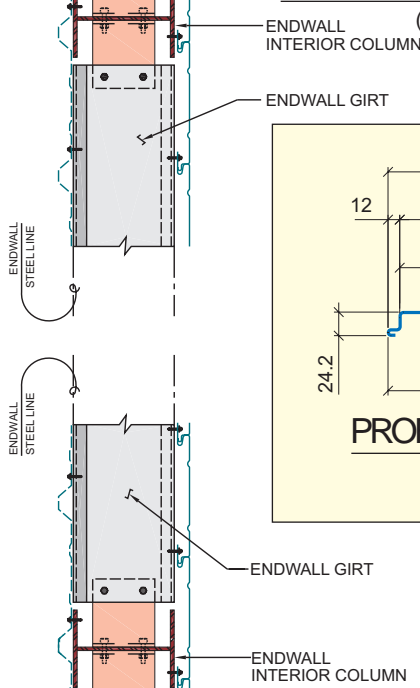

PROFILE "D" (SCULPTURED)

PROFILE "E" (FLAT)

PROFILE "D" & "E" LINER PANELS

**PLAN** : PROFILES "D" & "E" LINER PANEL DETAILS WITH P & B AT ENDWALL

(DETAILS FOR PROFILE "E" LINER PANELS ARE SIMILAR TO PROFILE "D" LINER PANELS AS SHOWN)  
[EXTERIOR WALL PANELS ARE SHOWN IN BROKEN LINES]

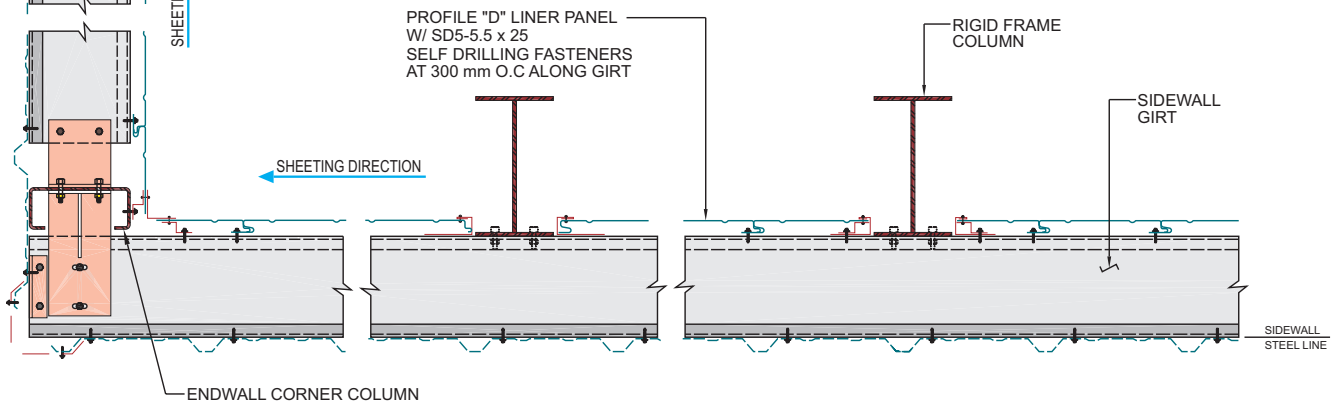





# **INSULATED SANDWICH PANELS**

# **C H A P T E R 9**

## 9. Insulated Sandwich Panels

9.1	General .....	203
9.2	Field Assembled Sandwich Panels (FASP) .....	204
9.3	Factory Injected Sandwich Panels (Tempcon) .....	208

Zamil Steel offers two types of insulated sandwich panels:

- Field Assembled Sandwich Panels (FASP)
- Factory Injected Sandwich Panels (Tempcon)

Tempcon panels are available in three types, Tempcon High-Rib (TCHR), Tempcon Low-Rib (TCLR) and Modified Tempcon (TCMD).

Tempcon and FASP insulated panels are available in several (overall) thicknesses offering a wide range of insulating R-Values. The following table summarizes the types of sandwich panels, areas of application, thicknesses, R-Values and single skin panels used for the outer and inner surfaces.

More details about Zamil Steel insulated sandwich panels are discussed further in this section.



Sandwich Panels	Insulation Type	Panel Type	Application	Available Thickness (mm)	R-Value (m2.K/W) range	Single Skin Panels *	
						Outer	Inner
Tempcon	Injected polyurethane	TCHR	Roof & Wall	65 – 130	2.27 – 5.88	“F”	“C”
		TCLR	Wall	35 – 100	1.96 – 5.56	“C”	
		TCMD	Roof & Wall	35 – 100	1.96 – 5.56	“B”	
FASP	Unfaced Fiberglass	FASP	Roof	50 – 100	1.51 – 2.81	“B”	“B”
			Wall		1.47 – 2.77	“R”	“R”

\* Please refer to the Zamil Steel Panel Chart (colors & profiles) for more details on single skin panel colors, thicknesses, substrates and profiles.

The Zamil Steel Field Assembled Sandwich Panels (FASP) is an insulated panel roof and wall system that is field assembled. It consists of four parts:

- A steel liner panel fastened to the roof purlins or wall girts.
- Sub-purlins/sub-girts.
- A layer of unfaced fiberglass insulation.
- An exterior steel panel fastened to the sub-purlins/sub-girts.

The sub-purlins/sub-girts are normally 50 mm, 75 mm or 100 mm deep, 1.5 mm thick cold-formed Z sections.

The standard unfaced fiberglass insulation has a density of 12 kg/m<sup>3</sup> or 16 kg/m<sup>3</sup> with higher densities available upon request.

The FASP system offers a variety of options in panel paint finish, panel thickness, insulation density and insulation thickness. This system is ideally suited for buildings that require good insulation at a reasonable cost and is an excellent alternative to polyurethane injected sandwich panels (Tempcon) due to its lower shipping cost.

The main advantages of the Zamil Steel FASP system when compared to polyurethane injected sandwich panels are:

- Low initial Ex-Factory cost.
- Low shipping cost.
- Equal or superior insulation values.

The R-Values of the FASP systems are noted in the following table:

Insulation		R-Value *	
Density (kg/m <sup>3</sup> )	Thickness (mm)	Roof & Wall	
		(H.ft <sup>2</sup> .°F/Btu)	(M <sup>2</sup> . K/W)
12	50	8.560	1.522
	75	12.076	2.147
	100	15.591	2.772
16	50	8.821	1.568
	75	12.466	2.216
	100	16.112	2.865

\* The R-Values are based on a mean temperature of 24° C (75° F)

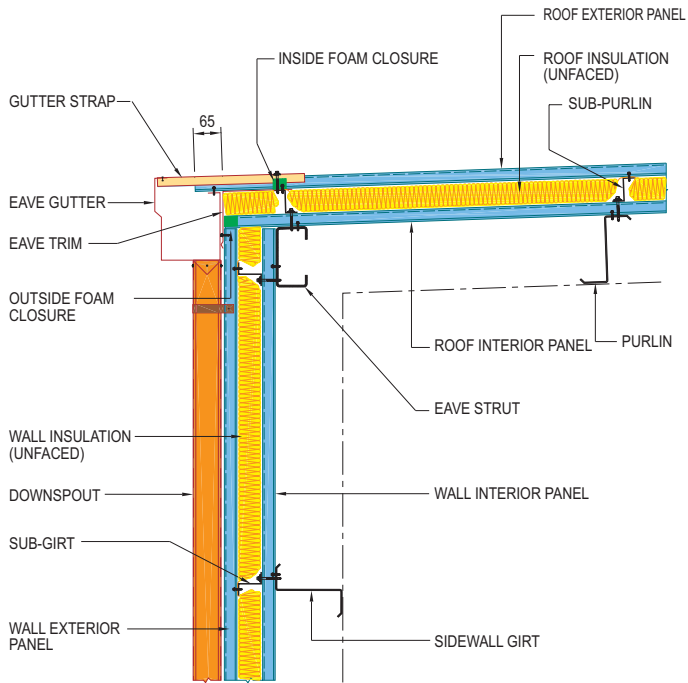

**DETAIL : FASP ROOF & WALL PANEL AT EAVE**

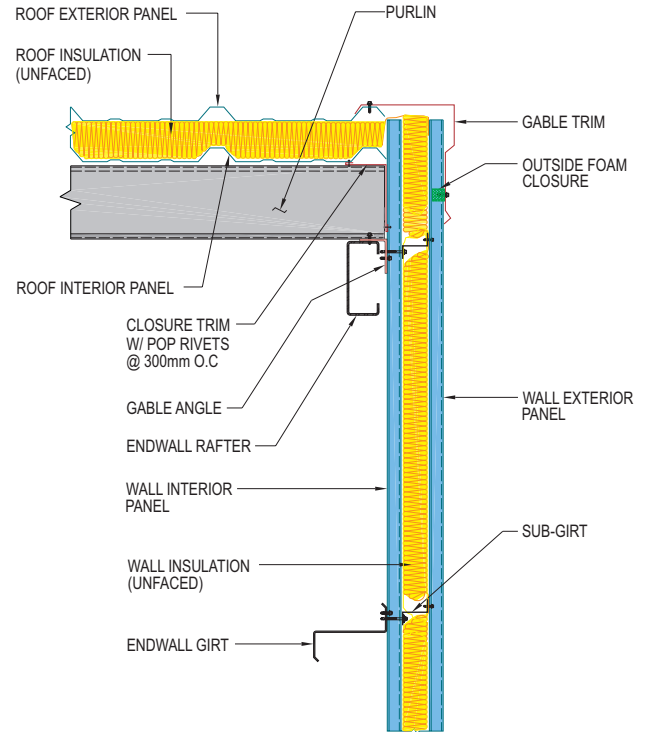

**DETAIL : FASP ROOF & WALL PANELS AT GABLE**

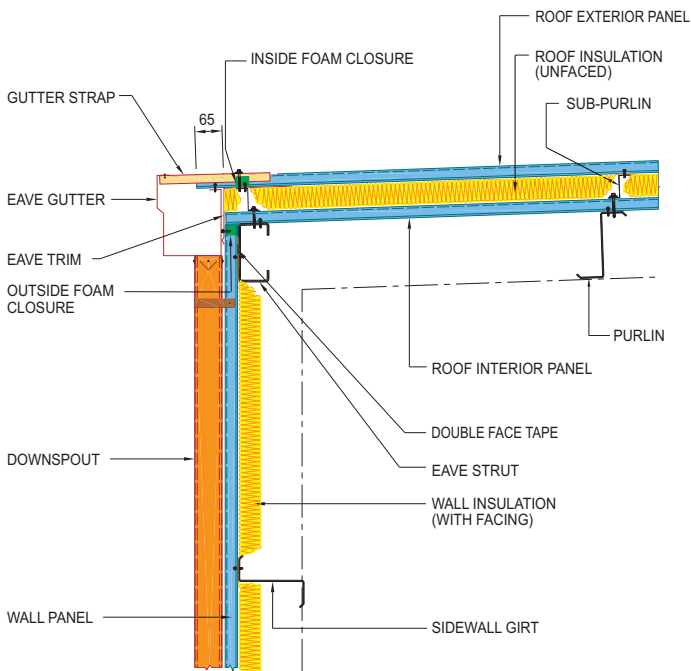

**DETAIL : FASP ROOF PANEL AT EAVE**

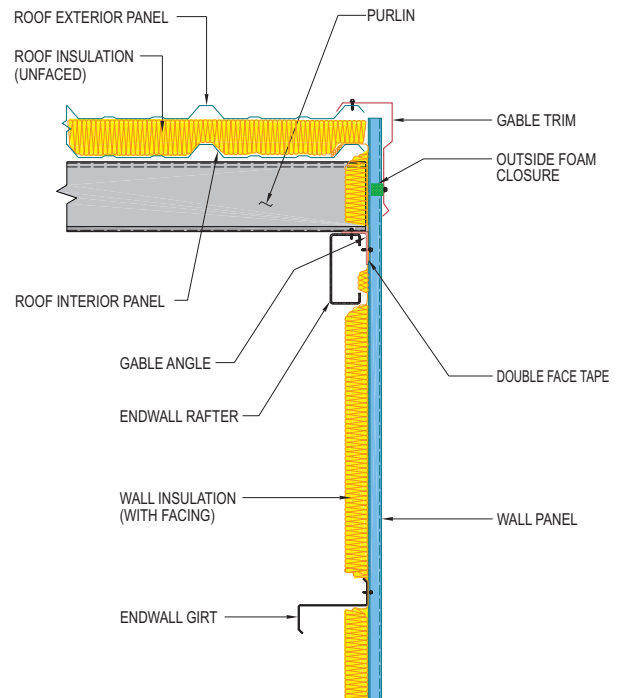

**DETAIL : FASP WALL PANEL AT GABLE**

NOTE:  
FOR EXTERIOR PANELS WITH PVF2 FINISH USE  
STAINLESS STEEL SCREWS.

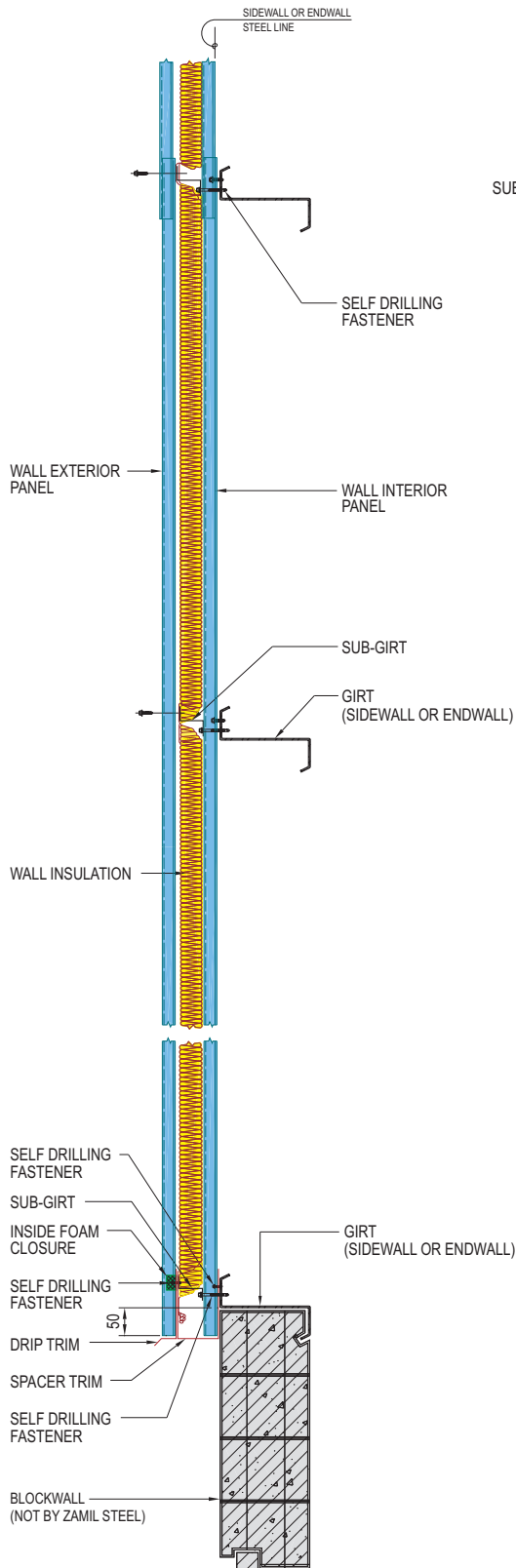

**DETAIL** : FASP WALL PANEL ABOVE BLOCKWALL

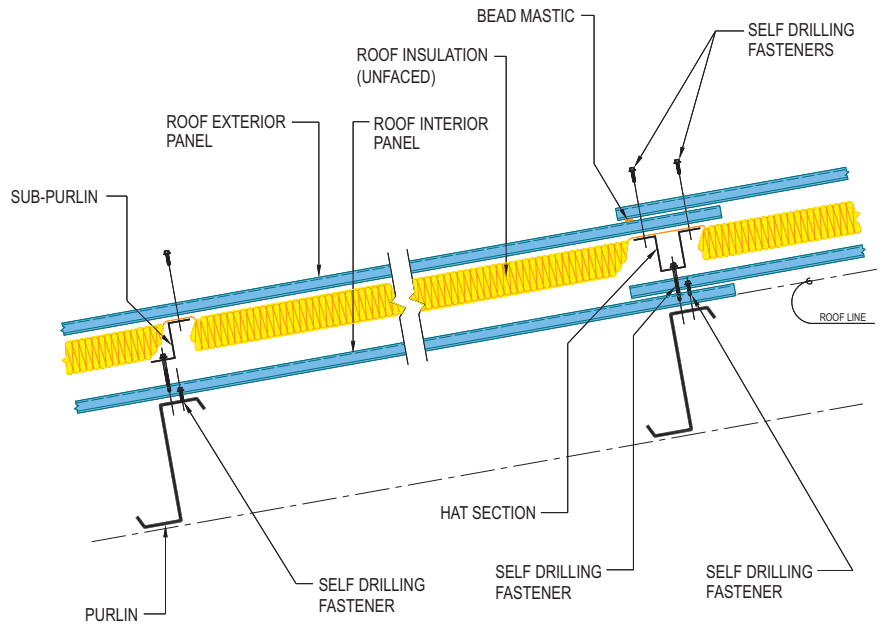

**DETAIL** : FASP ROOF PANEL ENDLAP AT PURLIN

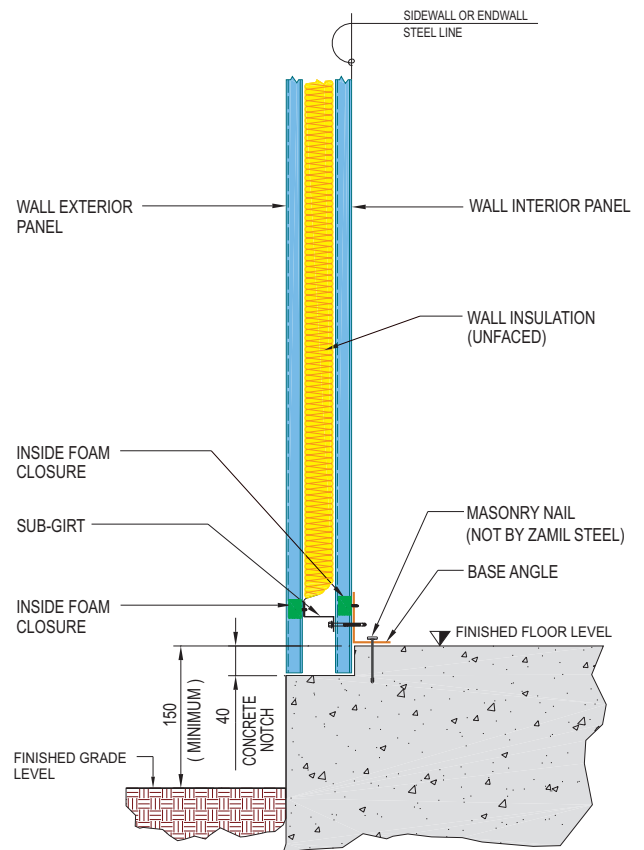

**DETAIL** : FASP WALL PANEL AT BASE

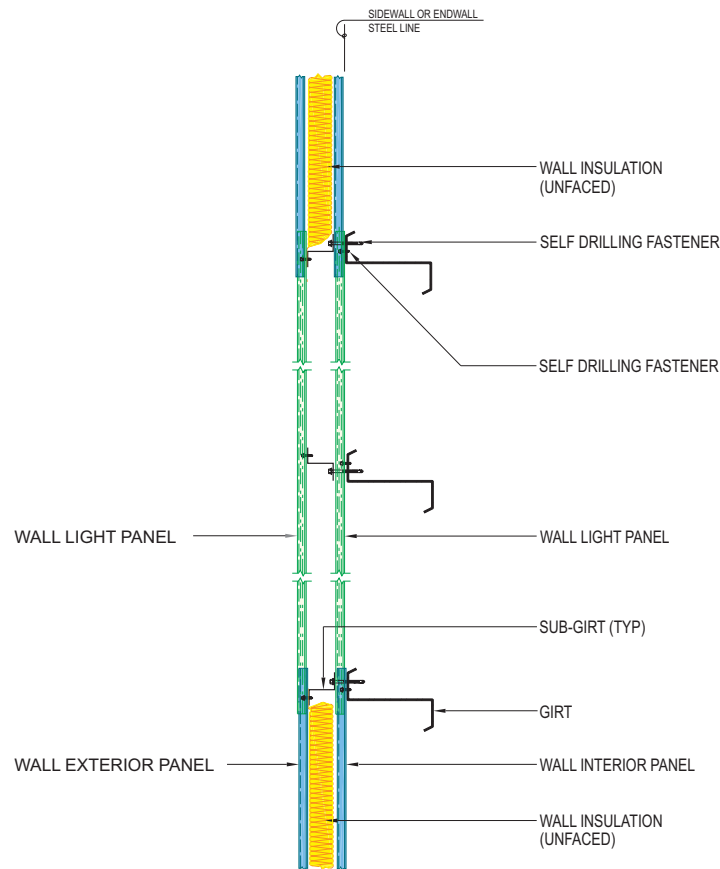

**DETAIL** : FASP WALL PANEL AT WALL LIGHT

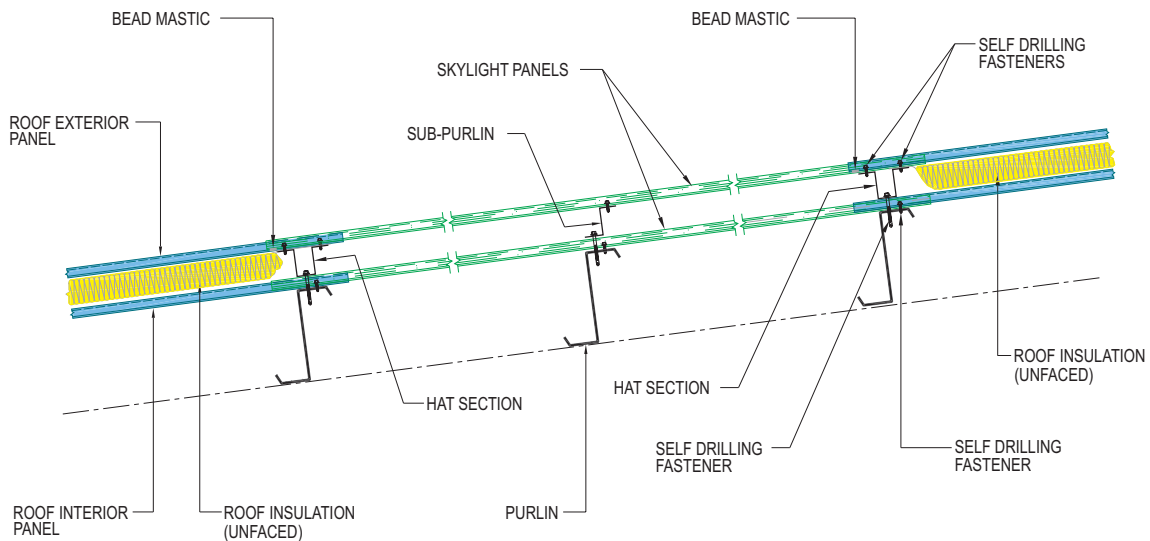

**DETAIL** : FASP ROOF PANEL AT SKYLIGHT

NOTE:  
FOR EXTERIOR PANELS WITH PVF<sub>2</sub> FINISH USE STAINLESS STEEL SCREWS.

**Factory Injected Sandwich Panels (Tempcon)** represent an important part of Zamil Steel's product line. In 1978, Zamil Steel became the first company in Saudi Arabia to manufacture insulated panels with its composite Low-Rib Tempcon (TCLR) wall and partition panel. In 1984, the two-piece Modified Tempcon (TCMD) insulated roof panel was introduced. In 1991, the composite High-Rib Tempcon (TCHR) roof and wall panel was produced.

Special skin thicknesses, paint finishes and colors are available upon request. These may be subject to extended delivery

This section presents the specification and details of each type of Tempcon panel (TCHR, TCLR and TCMD).

The table below represents Zamil Steel standard offering of Tempcon panels.

See **section 8.2** for specification details of bare Zinalume and pre-painted **XRW** (modified polyester polymer) Zinalume.

Aluminum panels are also available for Tempcon skins. The standard offering is 0.7 mm thick aluminum panel in Frost White color only.



<b>Exterior Metal Skin</b>	Panel Type	"F"	"C"	"B"	
	Nominal Thickness (mm)	0.5	0.5	0.5	
	Base Metal Coating		Zinalume	Zinalume	Zinalume
	Exposed Surface	Finish	Modified polyester polymer (XRW)	Modified polyester polymer (XRW)	Modified polyester polymer (XRW)
Color		Frost White	Any standard color	Any standard color	
<b>Interior Metal Skin</b>	Panel Type	"C"	"C"	"C"	
	Nominal Thickness (mm)	0.5	0.5	0.5	
	Base Metal Coating		Zinalume	Zinalume	Zinalume
	Exposed Surface	Finish	Modified polyester polymer (XRW)	Modified polyester polymer (XRW)	Modified polyester polymer (XRW)
Color		Frost White	Frost White	Frost White	



## Tempcon High-Rib "TCHR" Insulated Roof and Wall Panel (Composite)

### Physical Properties

TCHR panels are a composite of pre-painted metal skins with a foamed-in-place polyurethane core. The rigid foam core has a density of approximately 40 kg /m<sup>3</sup>.

Panels are factory-bonded insulated roof and wall cladding with a coverage width of 1065 mm. They are available in four thicknesses: 65 mm, 80 mm, 105 mm and 130 mm. The maximum panel length is 9.6 m.

Panel configuration is a foam core between a 5 rib (30 mm deep) exterior skin and a semi-flat low-rib interior skin. The substrate of the exterior and interior metal skins conform to ASTM A792 Grade 50B and is hot dip coated with a corrosion resistant zinc/aluminum alloy with 150 g/m<sup>2</sup> (total weight on both sides).

The exposed surface of the **exterior** metal skin is coated with modified polyester paint. The standard color is Frost White. The exposed surface of the **interior** metal skin is coated with modified polyester paint. The standard color is Frost White; other Zamil Steel standard colors are available as options.

Panels are end lapped by extending the exterior skin of one panel by 100 mm over the preceding panel. Side laps are provided by an offset configuration of the core. The exterior skin extends on one side beyond the core to overlap the next panel. The interior skin extends on the other side to underlap the preceding panel.

Panels are fastened with 5.5 mm diameter carbon steel self drilling fasteners.

### Performance Standards

Tempcon panels are intended for use as thermally efficient roof and wall cladding for buildings.

Each panel has a "U" shaped groove at the top of the edge rib providing a siphon break, which prevents water seepage through capillary action when lapped by the next panel.

Polyurethane contains HCFC, which is environmentally friendly and less destructive to the ozone layer.

Panel section properties (based on 0.5 mm thick steel exterior skin and 0.5 mm thick steel interior skin) are presented in the table on page 3 of 13 of this subsection.

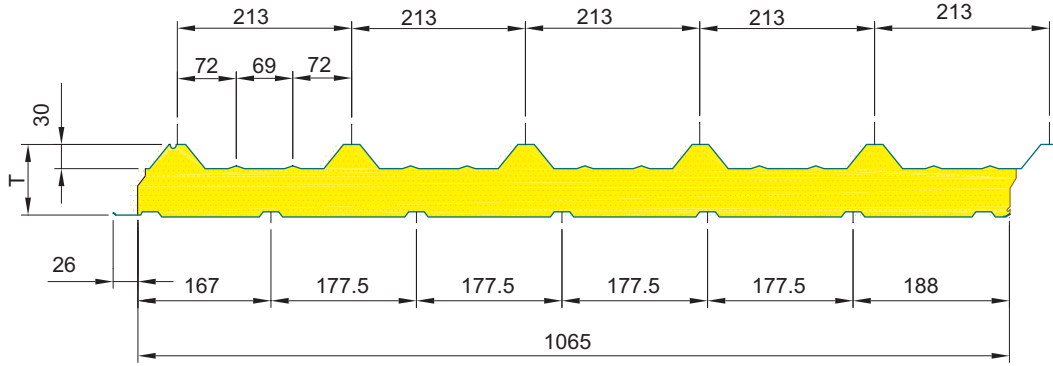

**TEMPCON HIGH-RIB "TCHR" INSULATED PANEL PROFILE**

**TEMPCON PANEL SECTION PROPERTIES\***

Panel Nominal Thickness "T" (mm)	Weight* (kg/m <sup>2</sup> )	I <sub>x</sub> (cm <sup>4</sup> ) Per 1 m Width	S <sub>x</sub> (cm <sup>3</sup> ) Per 1 m Width	U-Value (W/m <sup>2</sup> .K)	R-Value (m <sup>2</sup> .K/W)
65	9.48	50.4	12.0	0.44	2.27
80	10.08	64.4	18.6	0.33	3.03
105	11.08	191.2	31.0	0.22	4.55
130	12.08	289.9	44.2	0.17	5.88

\*Based on 0.5 mm thick (nominal) exterior steel skin and 0.5 mm thick (nominal) interior steel skin.

**TEMPCON PANEL ALLOWABLE UNIFORM LOADS (kN/m<sup>2</sup>)**

Panel Nominal Thickness "T" (mm)	Panel Span											
	2.50 m		3.00 m		3.50 m		4.00 m		4.50 m		5.00 m	
	S	D	S	D	S	D	S	D	S	D	S	D
65	1.64	3.90	1.37	2.26	1.17	1.42	1.03	0.95	0.91	0.67	0.75	0.49
80	2.24	7.17	1.87	4.15	1.60	2.61	1.40	1.75	1.25	1.23	1.12	0.90
105	3.24	14.81	2.71	8.57	2.32	5.40	2.03	3.60	1.80	2.54	1.62	1.85
130	4.25	22.46	3.54	13.00	3.03	8.18	2.66	5.48	2.36	3.85	2.12	2.80

Note: "S" refers to allowable load in kN/m<sup>2</sup> controlled by stress and "D" refers to allowable load in kN/m<sup>2</sup> controlled by deflection of span/180 for roof panels and span/120 for wall panels. Above values are calculated assuming three equal continuous spans.

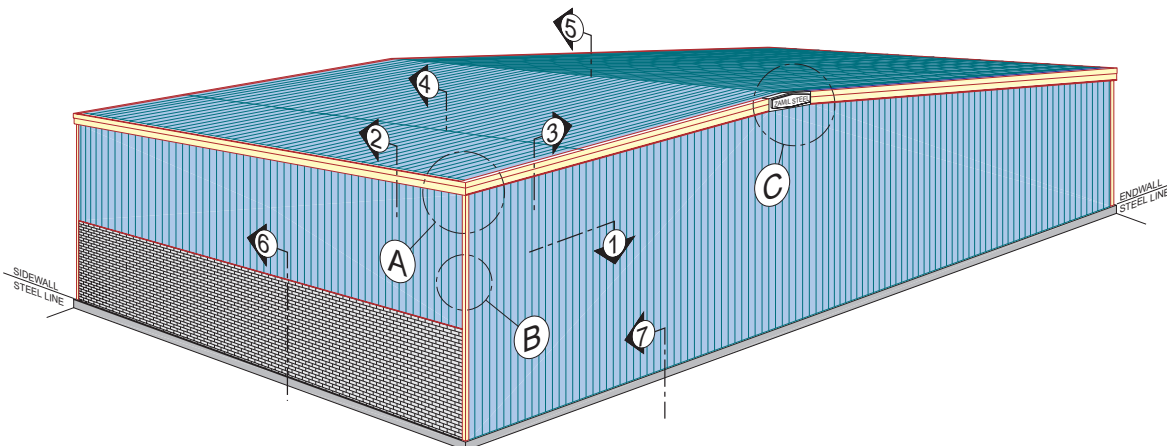

**ISOMETRIC : TEMPCON HIGH-RIB "TCHR" INSULATED PANEL AT ROOF AND WALL**

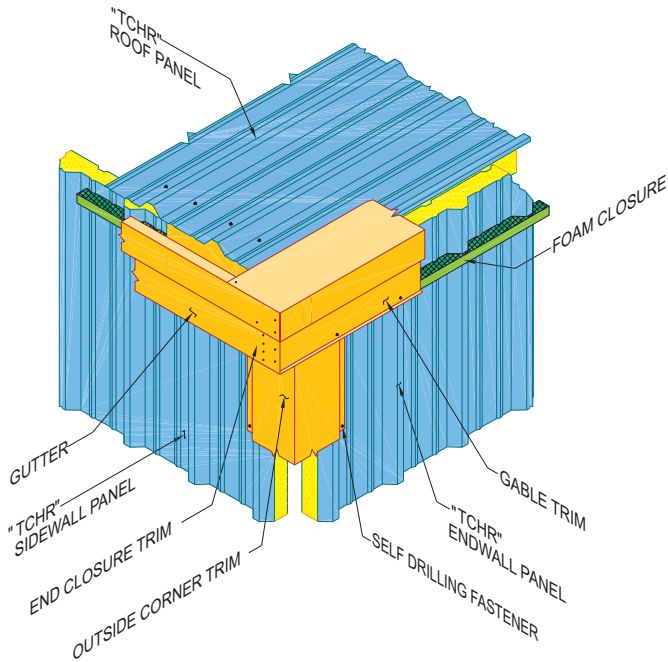

**DETAIL-A** : "TCHR" ROOF AND WALL PANEL AT CORNER EAVE

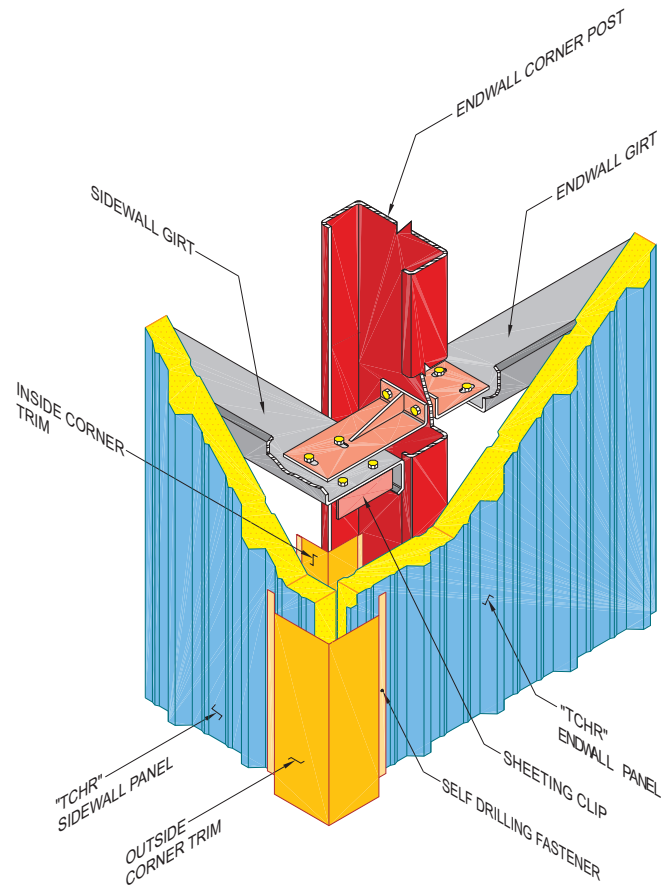

**DETAIL-B** : "TCHR" WALL PANEL AT CORNER

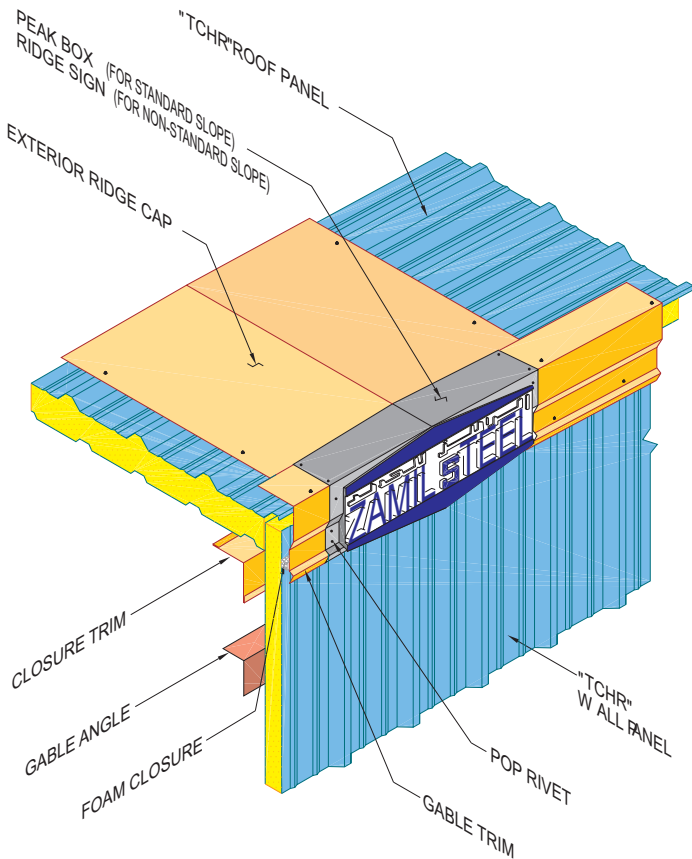

**DETAIL-C** : "TCHR" ROOF AND WALL PANEL AT RIDGE

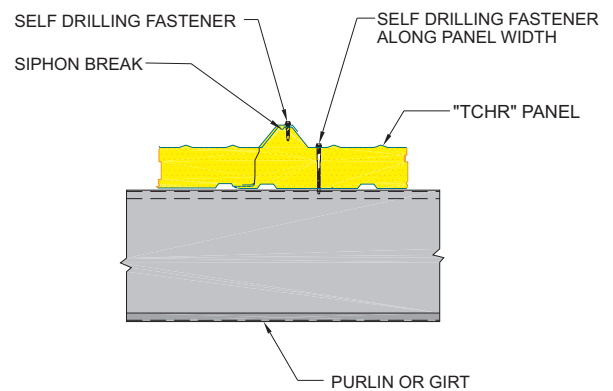

**SECTION-1** : "TCHR" ROOF AND WALL PANEL AT SIDELAP

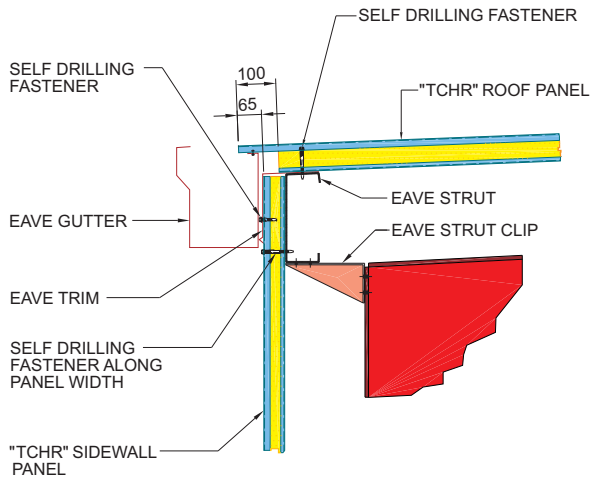

SECTION-2 : "TCHR" ROOF AND WALL PANEL AT EAVE

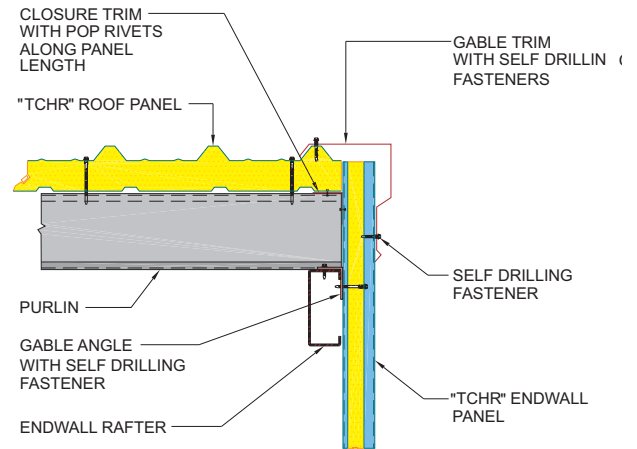

SECTION-3 : "TCHR" ROOF AND WALL PANEL AT GABLE

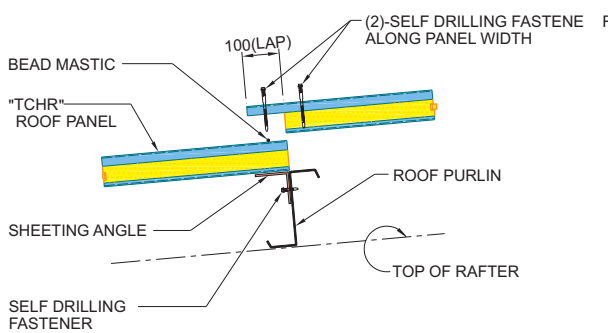

SECTION-4 : "TCHR" ROOF PANEL AT ENDLAP

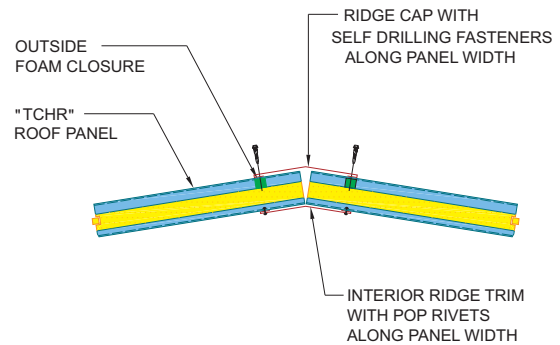

SECTION-5 : "TCHR" ROOF PANEL AT RIDGE

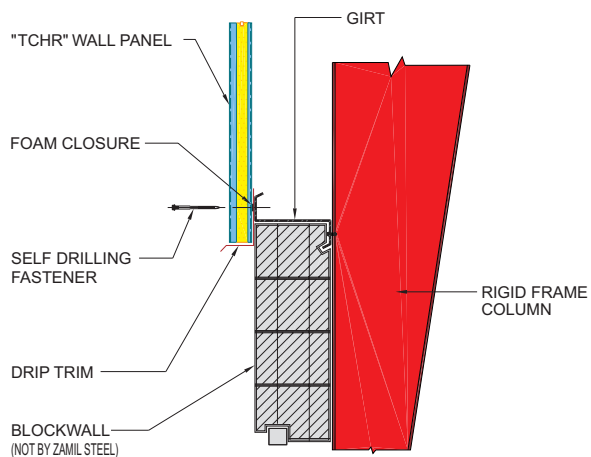

SECTION-6 : "TCHR" WALL PANEL ABOVE BLOCKWALL

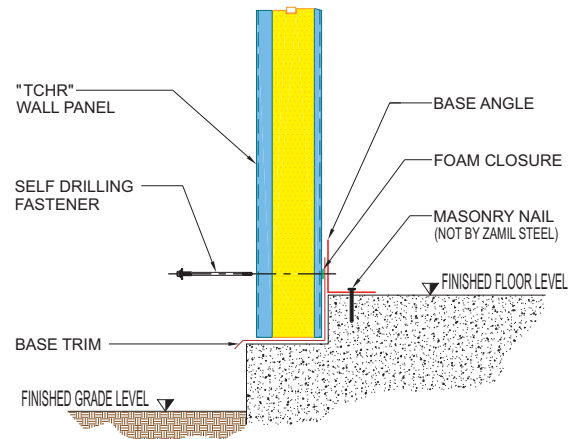

SECTION-7 : "TCHR" WALL PANEL AT FINISHED FLOOR

## Tempcon Low-Rib "TCLR" Insulated Wall and Partition Panel (Composite)

### Physical Properties

TCLR panels are a composite of pre-painted metal skins with a foamed-in-place polyurethane core. The rigid foam core has a density of approximately 40 kg /m<sup>3</sup>.

Panels are factory-bonded insulated roof and wall cladding with a coverage width of 1065 mm. They are available in four thicknesses: 35 mm, 50 mm, 75 mm and 100 mm. The maximum panel length is 9.6 m.

Panel configuration is a foam core between two semi-flat low-rib metal skins of identical profiles. The substrate of the exterior and interior metal skins conform to ASTM A792 Grade 50B and is hot dip coated with corrosion resistant zinc/aluminum alloy with 150 g/m<sup>2</sup> (total weight both on sides).

The exposed surface of the **exterior** metal skin is coated with modified polyester paint (XRW) and is available in any standard Zamil Steel color. The exposed surface of the **interior** metal skin is coated with modified polyester paint (XRW). The standard color is Frost White, other Zamil Steel standard colors are available as options.

Panels are end lapped by extending the exterior skin of one panel by 100 mm over the preceding panel. Side laps are provided by an offset configuration of the core. The exterior skin extends on one side beyond the core to overlap the next panel. The interior skin extends on the other side to underlap the preceding panel.

Panels are fastened with 5.5 mm diameter carbon steel self drilling fasteners.

### Performance Standards

Tempcon panels are intended for use as thermally efficient exterior wall cladding for building and as an interior partition panel inside buildings.

The side lap system provides continuity of profile shape along the wall or partition with identical appearance on both sides of the wall.

Polyurethane contains HCFC, which is environmentally friendly and not destructive to the ozone layer.

Panel section properties (based on 0.5 mm thick steel exterior skin and 0.5 mm thick steel interior skin) are listed in the table on page 7 of 13 of this section.

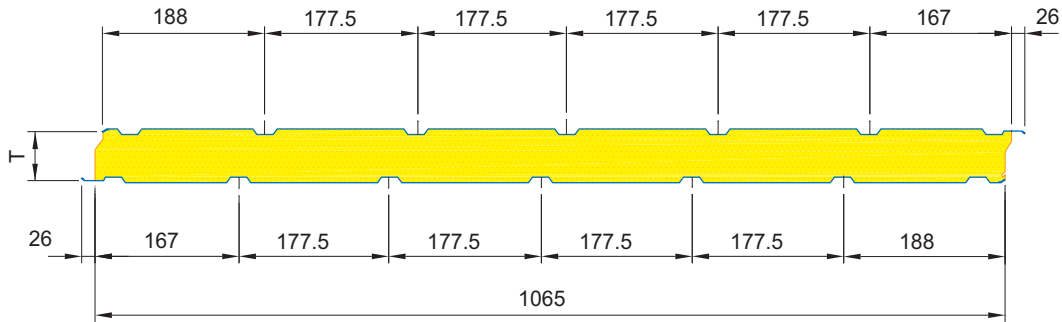

**TEMPCON LOW-RIB "TCLR" INSULATED PANEL PROFILE**

TEMPCON PANEL SECTION PROPERTIES*					
Panel Nominal Thickness "T" (mm)	Weight* (kg/m <sup>2</sup> )	I <sub>x</sub> (cm <sup>4</sup> ) Per 1 m Width	S <sub>x</sub> (cm <sup>3</sup> ) Per 1 m Width	U-Valve (W/m <sup>2</sup> .K)	R-Valve (m <sup>2</sup> .K/W)
35	8.74	30.5	17.3	0.51	1.96
50	9.34	64.4	25.3	0.36	2.78
75	10.34	144.9	37.9	0.24	4.17
100	11.34	257.9	50.6	0.18	5.56

\*Based on 0.5 mm thick (nominal) exterior steel skin and 0.5 mm thick (nominal) interior steel skin.

TEMPCON PANEL ALLOWABLE UNIFORM LOADS (kN/m <sup>2</sup> )												
Panel Nominal Thickness "T" (mm)	Panel Span											
	2.50 m		3.00 m		3.50 m		4.00 m		4.50 m		5.00 m	
	S	D	S	D	S	D	S	D	S	D	S	D
35	1.40	1.81	1.17	1.04	1.00	0.66	0.88	0.44	0.76	0.31	0.62	0.22
50	2.00	3.81	1.67	2.20	1.43	1.39	1.25	0.93	1.10	0.65	0.90	0.47
75	3.01	8.55	2.51	4.94	2.15	3.11	1.88	2.10	1.66	1.46	1.35	1.06
100	4.01	15.20	3.34	8.80	2.86	5.56	2.51	3.72	2.22	2.62	1.80	1.90

Note: "S" refers to allowable load in kN/m<sup>2</sup> controlled by stress and "D" refers to allowable load in kN/m<sup>2</sup> controlled by deflection of span/180 for roof panels and span/120 for wall panels. Above values are calculated assuming three equal continuous spans.

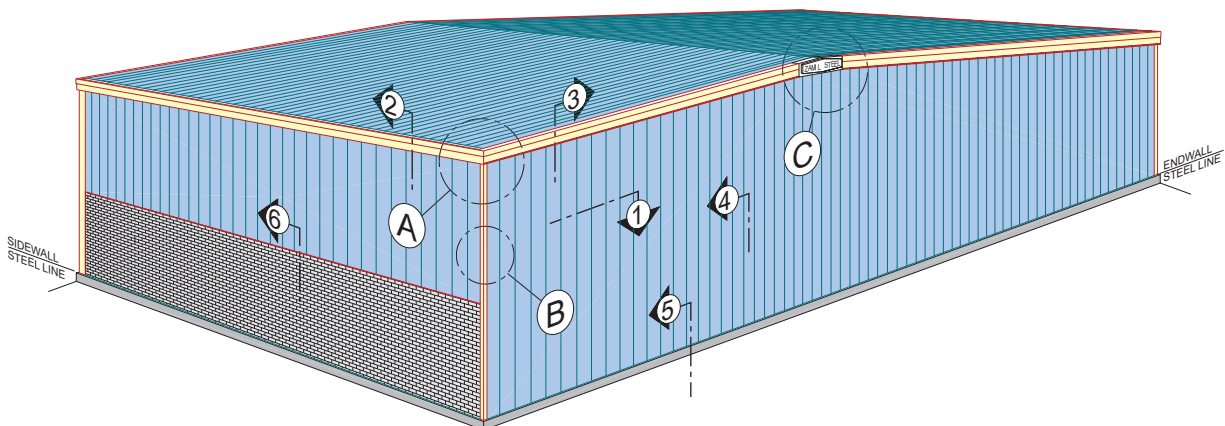

**ISOMETRIC : TEMPCON LOW-RIB "TCLR" INSULATED PANEL ATWALL**

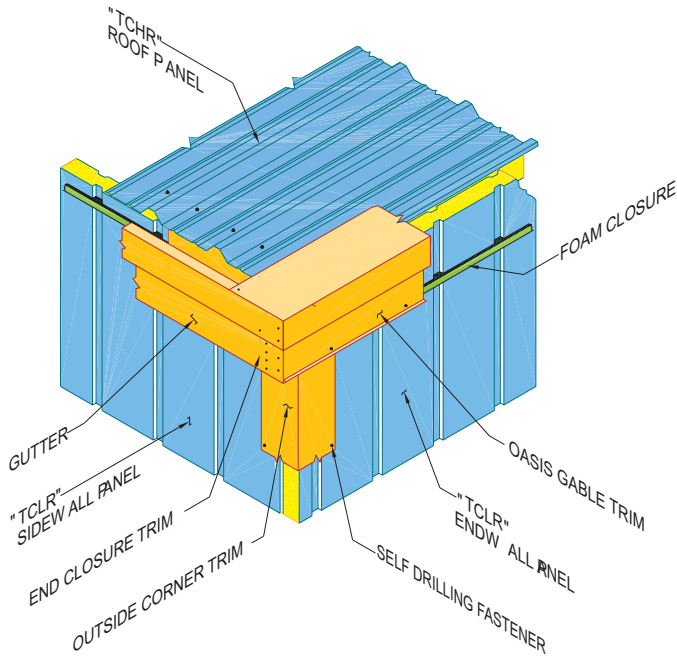

**DETAIL-A** : "TCLR" WALL PANEL AT CORNER EAVE

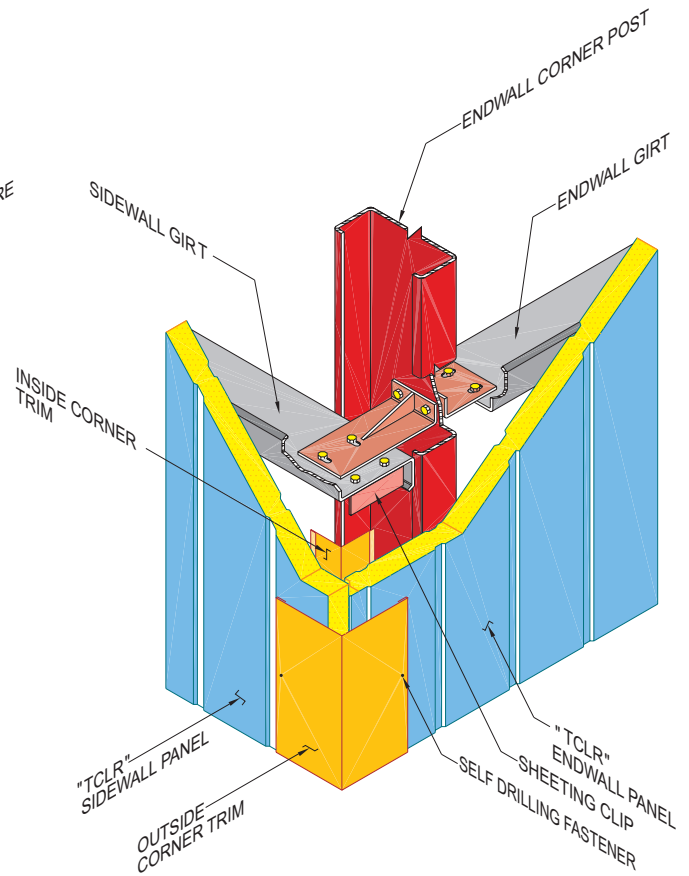

**DETAIL-B** : "TCLR" WALL PANEL AT CORNER

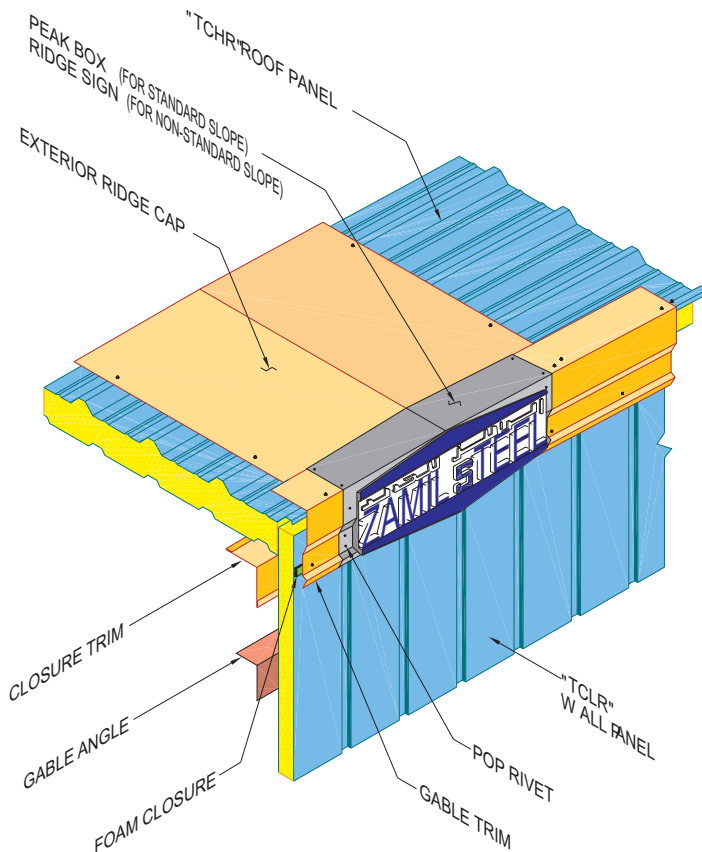

**DETAIL-C** : "TCLR" WALL PANEL AT RIDGE

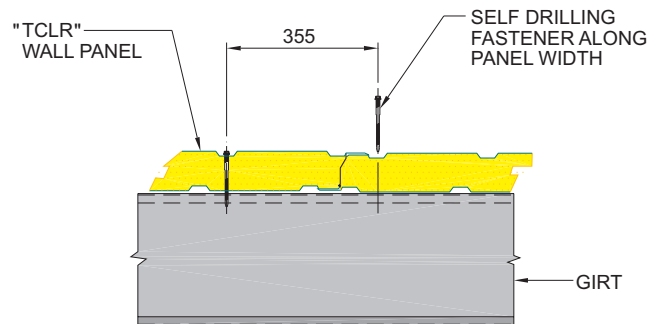

**SECTION-6** : "TCLR" WALL PANEL AT SIDELAP

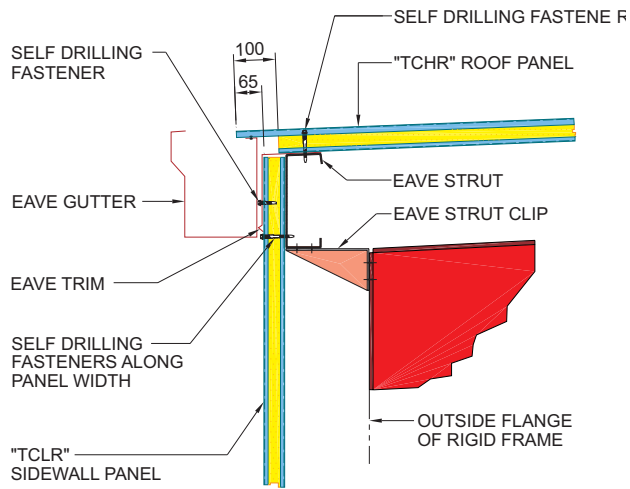

SECTION-2 : "TCLR" WALL PANEL AT EAVE

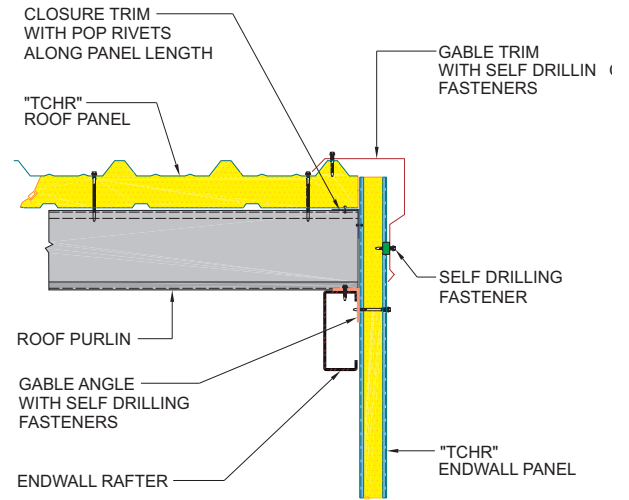

SECTION-3 : "TCLR" WALL PANEL AT GABLE

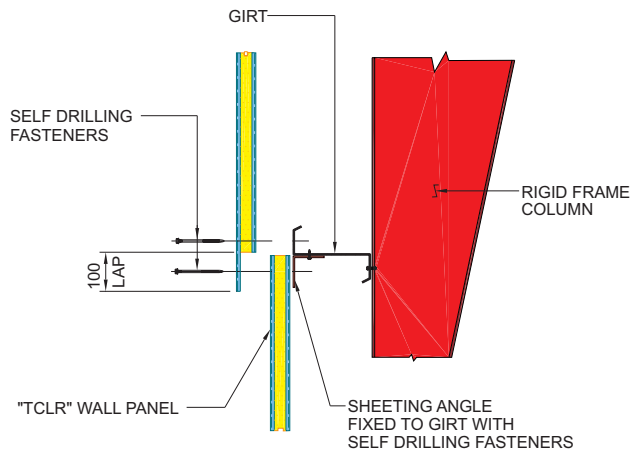

SECTION-4 : "TCLR" WALL PANEL AT ENDLAP

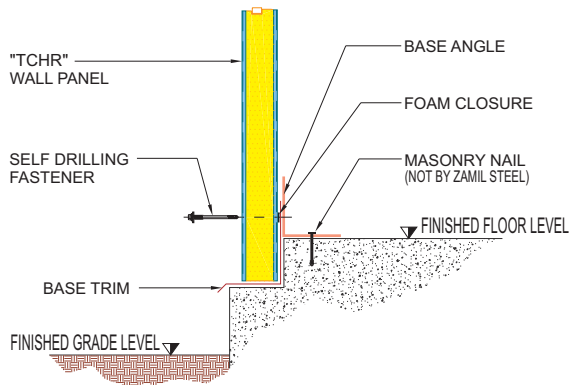

SECTION-5 : "TCLR" WALL PANEL AT FINISHED FLOOR

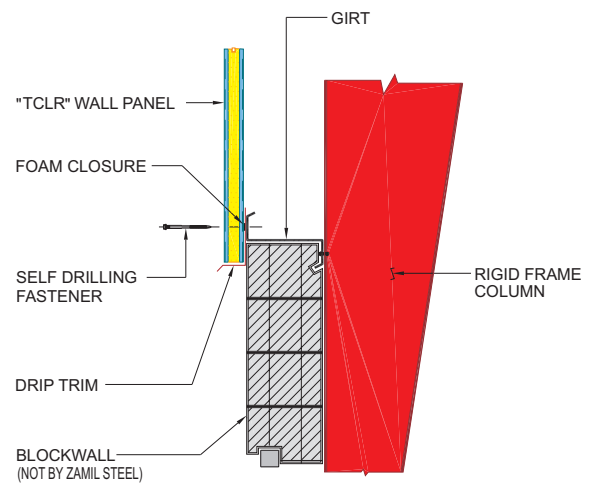

SECTION-6 : "TCLR" WALL PANEL ABOVE BLOCKWALL



### Modified Tempcon "TCMD" Insulated Roof Panel (Two Piece)

#### Physical Properties

TCMD panels comprise of two pieces that are field assembled to create a composite insulated panel system.

The standard exterior metal skin (overlay) of the insulated panel is a Profile "B" panel, which has a coverage width of 960 mm. Other Zamil Steel panel profiles to suit specific requirements can also be used. For more information consult the nearest Zamil Steel representative.

The interior metal skin of the panel is a Profile "C" panel factory-bonded to a rigid polyurethane core, with a coverage width of 1065 mm. The polyurethane thicknesses are: 35 mm, 50 mm, 75 mm and 100 mm. The maximum panel length is 9.6 m.

The substrate of the **exterior** and **interior** metal skins conform to ASTM A792 Grade 50B and is hot dip coated with a corrosion resistant zinc/aluminum alloy with 150 g/m<sup>2</sup> (total weight on both sides).

The exposed surface of the exterior skin is first mill finished with Zinalume and then painted in any standard Zamil Steel color. The exposed surface of the interior metal skin is coated with modified polyester paint (XRW). The standard color is Frost White, other standard Zamil Steel colors are available as options.

The field assembly of the two-piece panel allows for possible dismantling and, in the event that excessive weathering requires, the replacement of the exterior skin. This is achieved without disturbing the interior foam core panel.

Panels are end lapped by extending the exterior skin of the panel by 150 mm over the preceding panel.

Side laps of exterior skin are provided by lapping two adjacent major ribs of the exterior skin and by an offset joint of the foam core. The interior skin panel extends beyond the foam core to lap the edge of the preceding interior skin panel.

Panels are fastened with 5.5 mm diameter carbon steel self drilling fasteners.

#### Performance Standards

Tempcon panels are intended for use as thermally efficient roof cladding for buildings.

Polyurethane contains HCFC, which is environmentally friendly and not destructive to the ozone layer.

For U-values and R-values of the different foam thicknesses refer to the table on page 7 of 13 for Tempcon Low-Rib panels.

Panel section properties (based on top sheet performance only) are listed in the table on page 11 of 13 of this section. Structural panel properties are achieved by the contribution of the exterior skin only (the exterior skin is not structurally bonded to the bottom foamed panel).

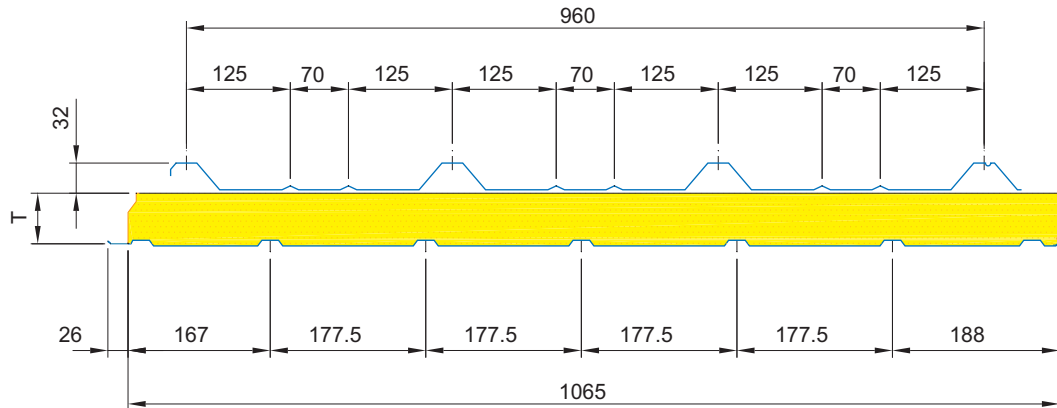

**MODIFIED TEMPCON "TCMD" INSULATED PANEL PROFILE**

PANEL SECTION PROPERTIES							
"TCMD" PANEL		Exterior Skin Nominal Thickness* (mm)	Weight* (kg/m <sup>2</sup> )	Top in Compression		Bottom in Compression	
Nominal Thickness (mm)	Weight** (kg/m <sup>2</sup> )			I <sub>x</sub> (cm <sup>4</sup> )	S <sub>x</sub> (cm <sup>3</sup> )	I <sub>x</sub> (cm <sup>4</sup> )	S <sub>x</sub> (cm <sup>3</sup> )
35	9.75	0.50 Steel	4.68	4.47	1.39	2.55	1.53
50	10.35						
75	11.35						
100	12.35						

\* Denotes exterior steel skin nominal thickness and weight for Profile "B" steel panel but the exterior skin can be either Profile "A" or Profile "B". For Profile "A" nominal thickness and weight see page 2 of 8 of section 8.5.

\*\* The weight calculated is based on outer skin nominal thickness of 0.5 mm Profile "B" steel panel.

PANEL ALLOWABLE UNIFORM LOADS (kN/m <sup>2</sup> )						
Exterior Skin Nominal Thickness* (mm)	Panel Span					
	1.00 m		1.50 m		2.00 m	
	S	D	S	D	S	D
0.50 Steel	3.00	7.30	1.83	2.16	0.75	0.91

Note: 1. "S" refers to allowable load in kN/m<sup>2</sup> controlled by stress and "D" refers to allowable load in kN/m<sup>2</sup> controlled by deflection of span/180 for roof panels. Above values are calculated assuming three equal continuous spans.

2. Allowable values for Modified Tempcon panels are based on properties of exterior skin of the composite panel.

3. For "U" and "R" values of different foam-core thicknesses refer to the Low-Rib Tempcon panel table on page 7 of 13 of this sub-section.

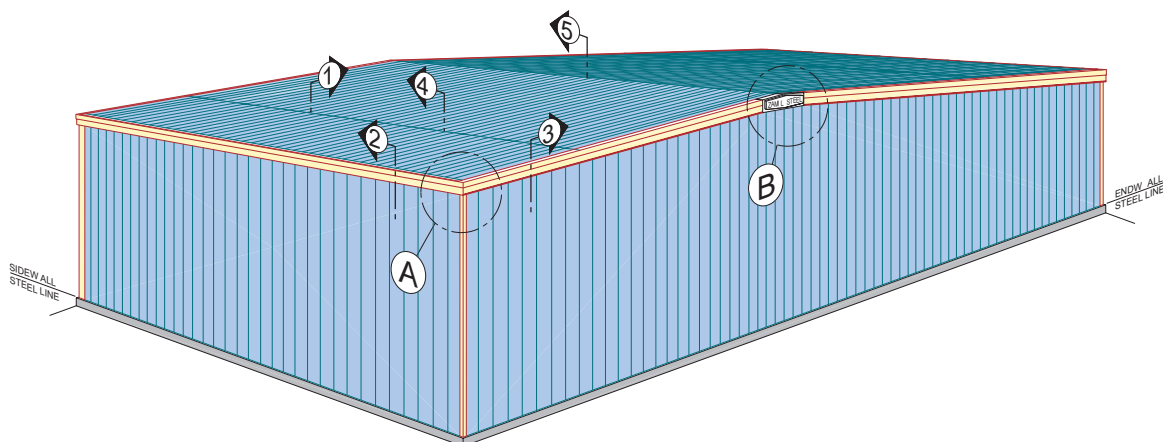

**ISOMETRIC : MODIFIED TEMPCON "TCMD" INSULATED PANEL AT ROOF**

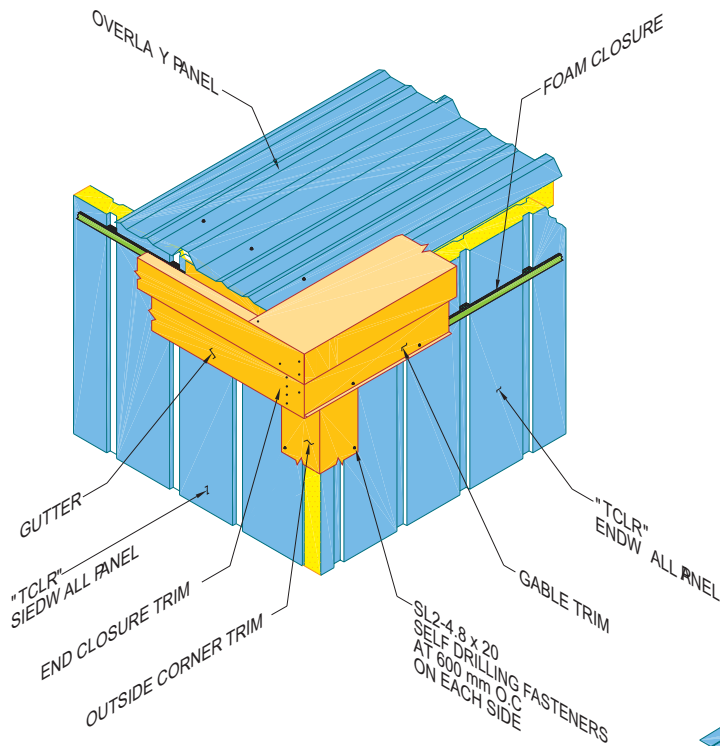

**DETAIL-A**: "TCMD" ROOF PANEL AT CORNER EAVE

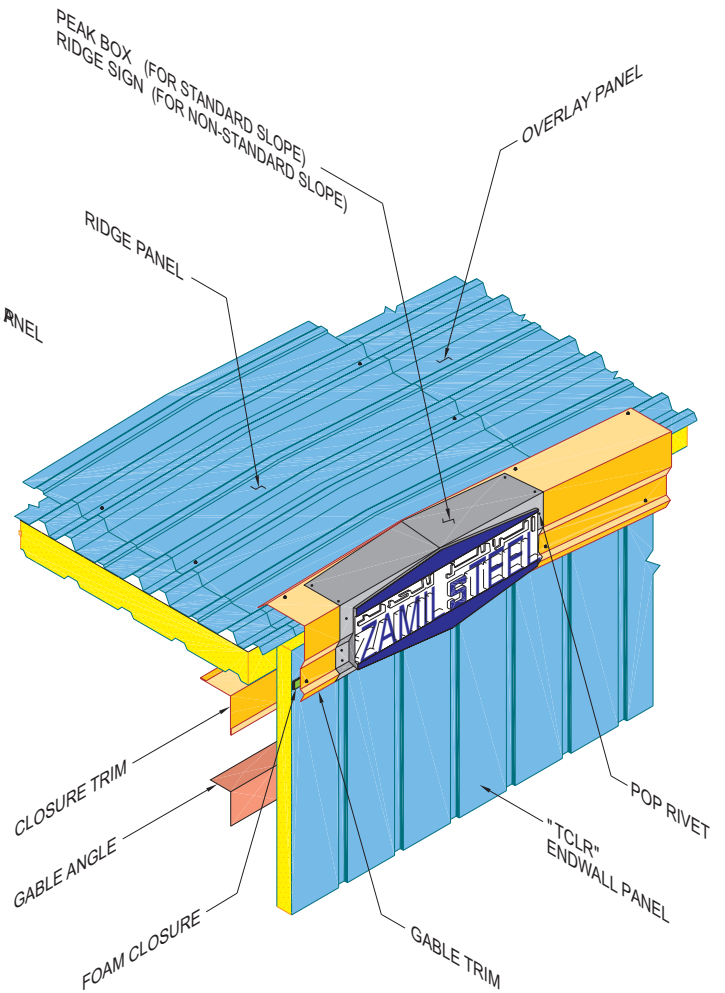

**DETAIL-B**: "TCMD" ROOF PANEL AT RIDGE

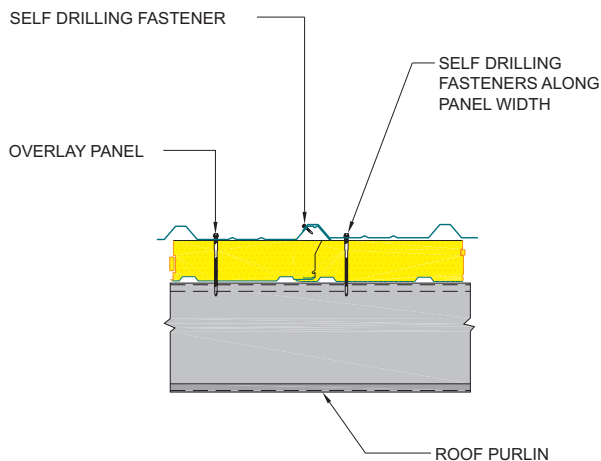

**SECTION-1**: "TCMD" ROOF PANEL AT SIDELAP

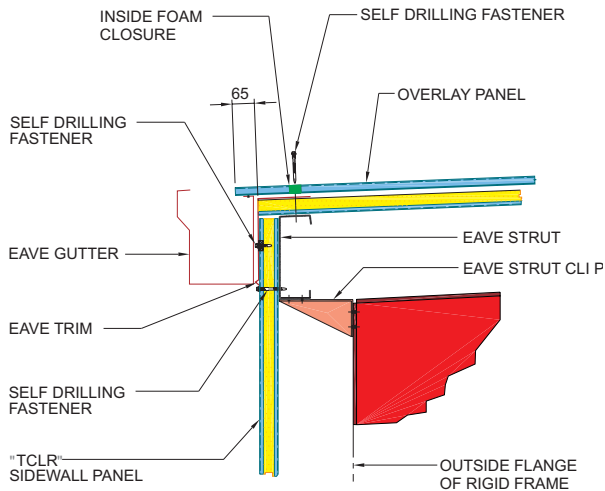

SECTION-2: "TCMD" ROOF PANEL AT EAVE

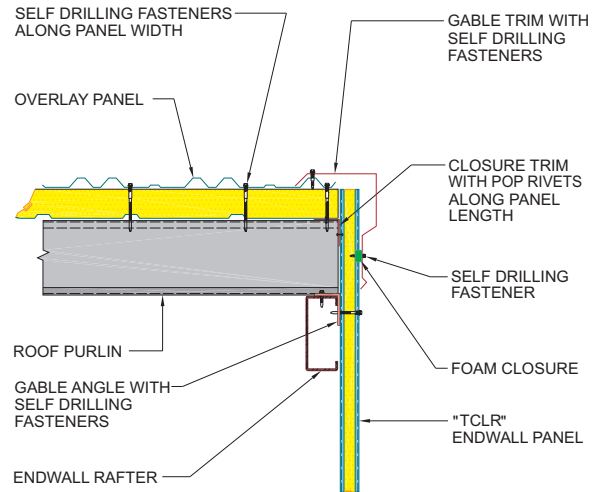

SECTION-3: "TCMD" ROOF PANEL AT GABLE

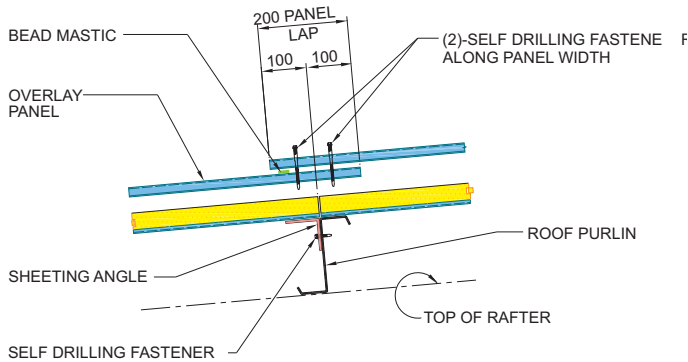

SECTION-4: "TCMD" ROOF PANEL AT ENDLAP

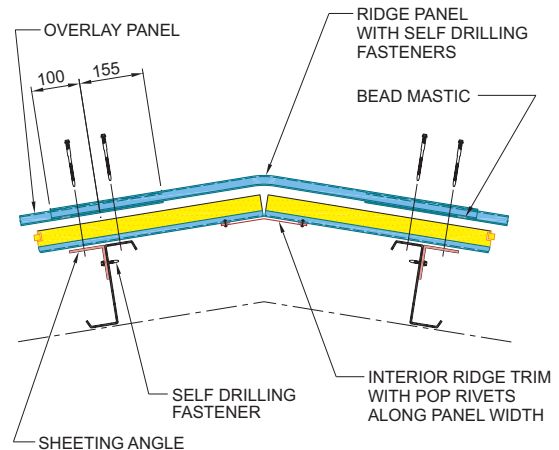

SECTION-5: "TCMD" ROOF PANEL AT RIDGE

# PANEL RELATED ACCESSORIES

C  
H  
A  
P  
T  
E  
R

10

# 10. Panel Related Accessories

- 10.1 General ..... 223
- 10.2 Curved Eaves ..... 224
- 10.3 Flashing and Trims ..... 226
- 10.4 Gutters and Downspouts ..... 229

Panel related accessories are items that are manufactured from the same materials as single skin panels i.e., from sheeting coils.

These are the items that contribute to the function, beauty, tightness and completeness of Zamil Steel pre-engineered buildings.

Panel related accessories include primarily the following:

- Curved Eaves
- Flashing and Trims
- Gutters and Downspouts

For further information on the material specifications, base metal, metal substrate, paint systems or coating specifications please refer to **chapter 8**.



Zamil Steel's standard **curved eave** is a Eurostyled corrugated panel that matches the profile of the roof and wall panels. It is available in Profile "A" and Profile "B" panels in all Zamil Steel's standard colors. Profile "R" curved panel is also available and is used to match the wall panels for curved eaves with valley gutters and without projection.

A curved eave can be an attractive feature in canopies, vehicle parking shelters (see **section 17.2**), service stations (see **section 17.3**) and other structures requiring an even and smooth architectural style at the eave.

The graceful appearance of a curved eave adds elegance to a building and gives it an impressive look that distinguishes it from neighboring buildings.

In countries such as those in the Arabian peninsula, where dry climates prevail throughout the year, providing a curved eave to your building is a sound and economical decision. Frequent sandstorms often result in sand buildup at the eave of the roof and prolonged entrapment of the sand in the gutters that can cause gradual corrosion of the roof panels adjacent to the eave. Curved eaves have no obstructing parts that hold the sand particles, thereby greatly minimizing the need for frequent cleaning and maintenance. Buildings surrounded by trees can also benefit from the special shape of the curved eave.

When building budgets are tight, curved eaves can be a good alternative to fascias. They greatly enhance the beauty of buildings without incurring high costs or sacrificing the beauty and grandeur of the building.





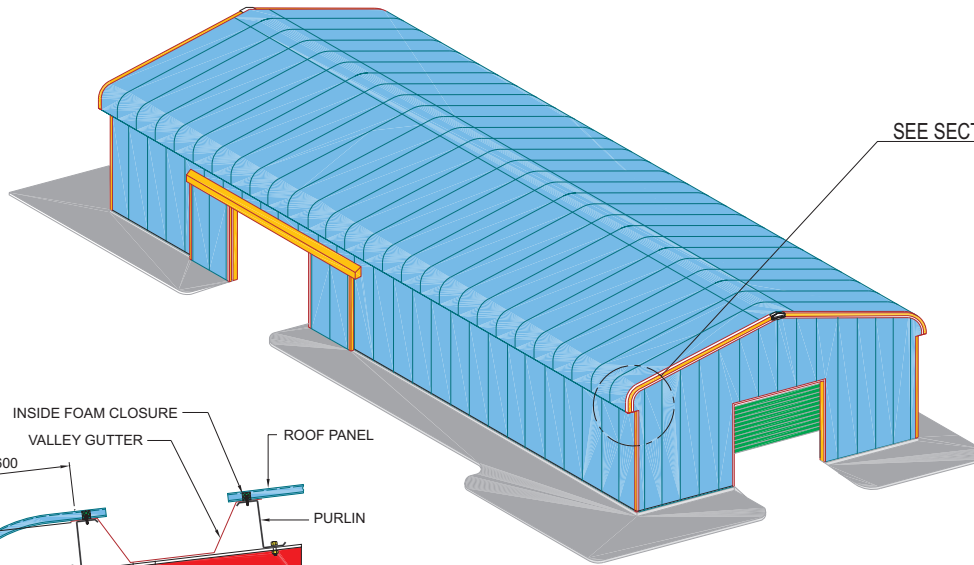

SEE SECTION FOR DETAILS

**ISOMETRIC : CURVED EAVES**

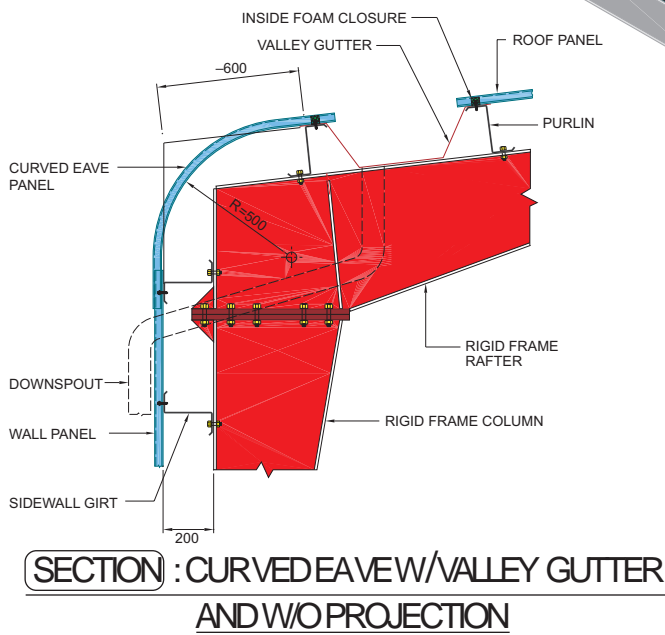

**SECTION : CURVED EAVE W/ VALLEY GUTTER AND W/O PROJECTION**

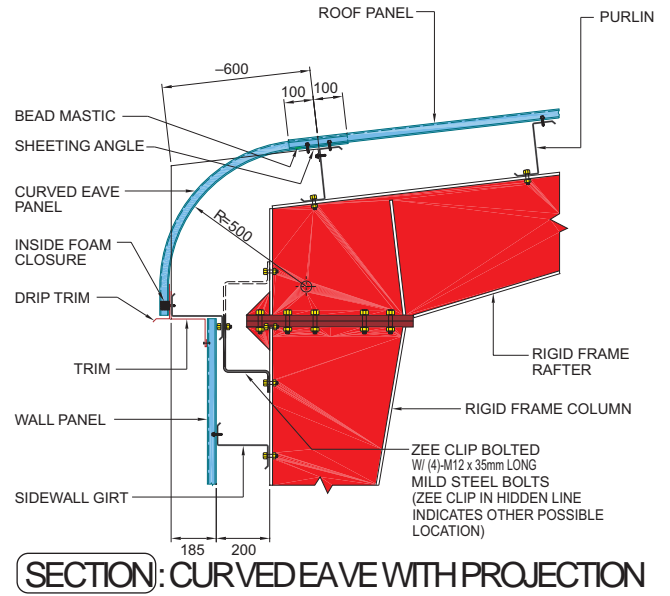

**SECTION : CURVED EAVE WITH PROJECTION**

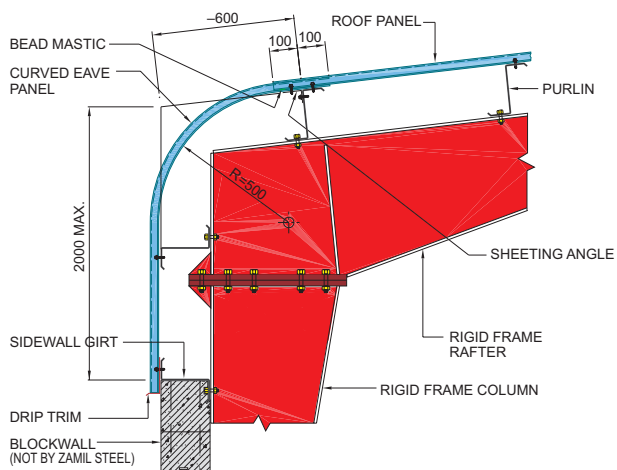

**SECTION : CURVED EAVE W/ VALLEY GUTTER AND PROJECTION [AT BLOCKWALL]**

**Flashing and trims** are sheet metal closures designed primarily to provide weather tightness and neat appearance at corners and junctions. (The name flashing and trims are used synonymously).

Nothing enhances the overall appearance of a pre-engineered steel building more than the correct and appropriate trim. Standard building accessories (such as, ridge ventilators, windows, personnel doors, louvers, roll-up doors, sliding doors, framed openings etc), partitions, fascias, canopies and other special supplemental attachments combined with flashing and trims create a blend of artistic harmony and serene splendor for the most discriminating engineers, architects and the public.

The most common trims are noted below. They are roll-formed from 0.5mm thick (nominal) pre-painted Zinalume sheeting coils available in all Zamil Steel standard colors.

- Eave trims
- Gable trims
- Corner trims

All other trims and flashing are press broken from standard pre-painted Zinalume 0.5 mm thick (nominal) sheeting available in all Zamil Steel standard colors.

Any type of flashing or trim can be manufactured at Zamil Steel. Architects can develop elegant details using trims that they create to suit any desired application.



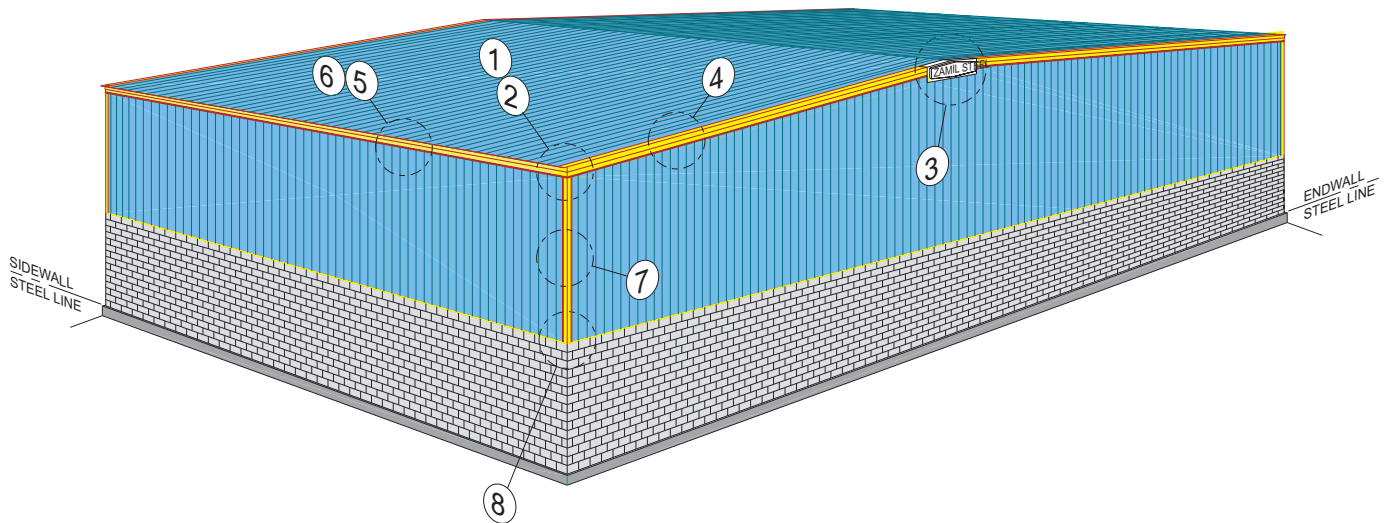

ISOMETRIC : TYPICAL FLASHING AND TRIMS AT ROOF AND WALLS

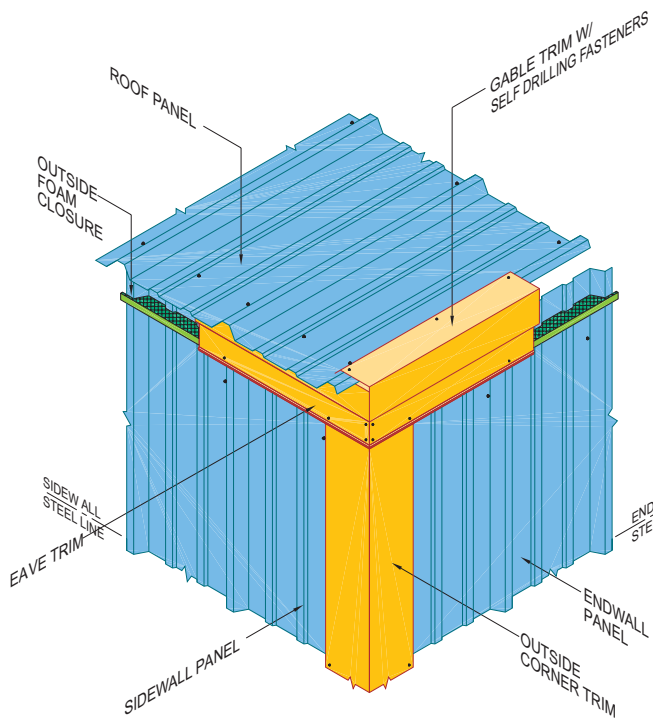

DETAIL-1 : GABLE TRIM WITH EAVE TRIM

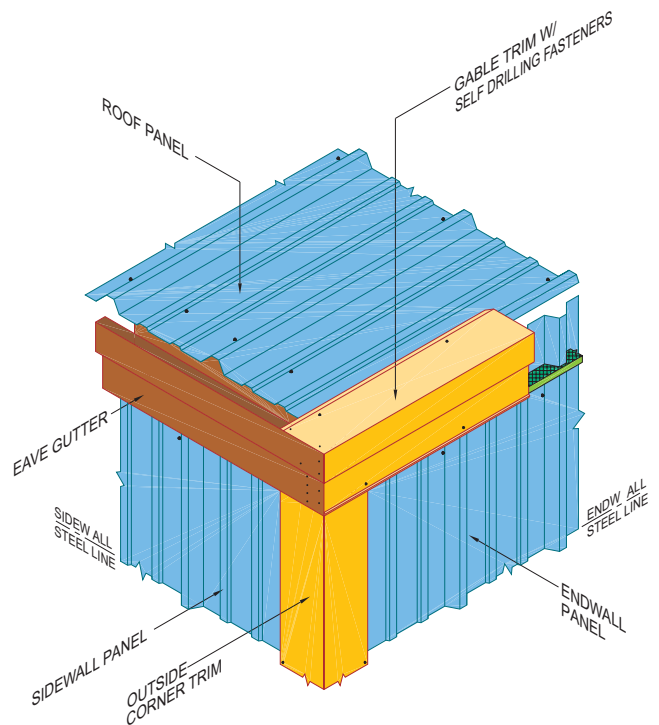

DETAIL-2 : GABLE TRIM WITH EAVE GUTTER

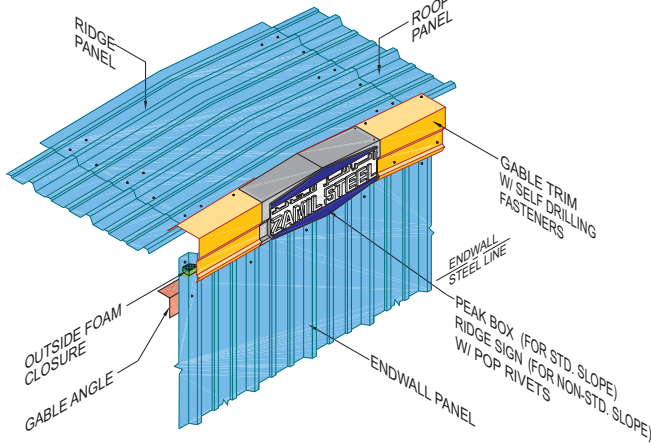

**DETAIL-3** : GABLE TRIM AND PEAK BOX AT RIDGE

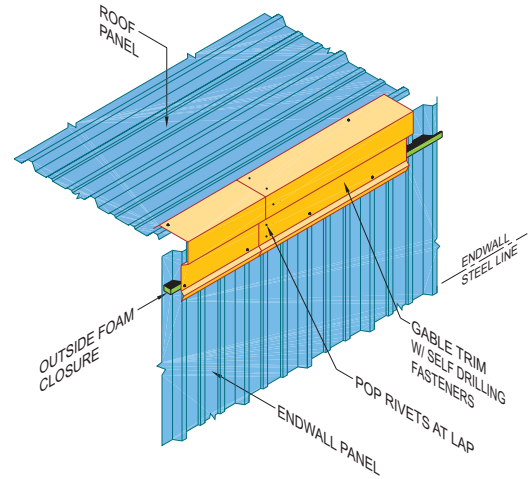

**DETAIL-4** : GABLE TRIM AT ENDWALL

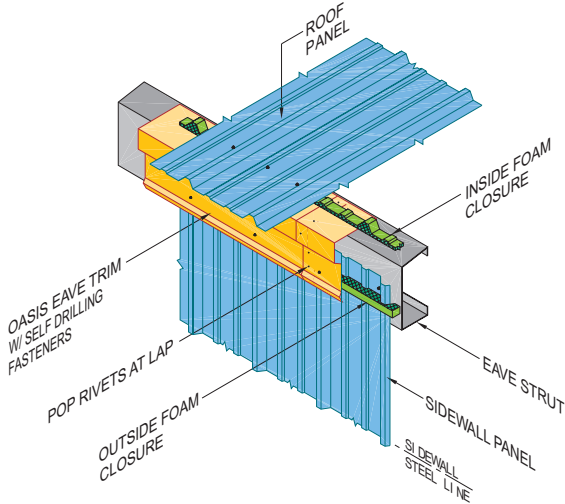

**DETAIL-5** : OASIS EAVE TRIM

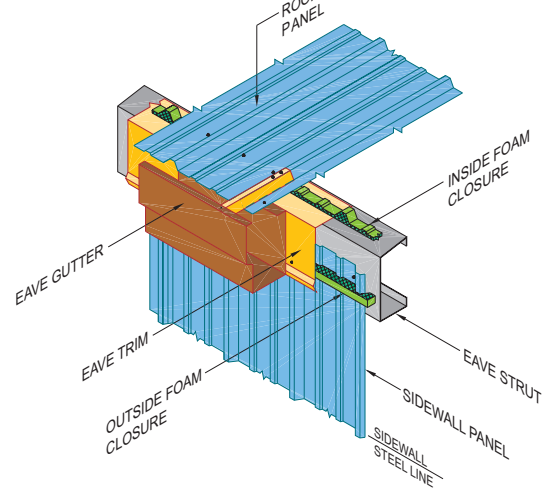

**DETAIL-6** : OASIS EAVE GUTTER

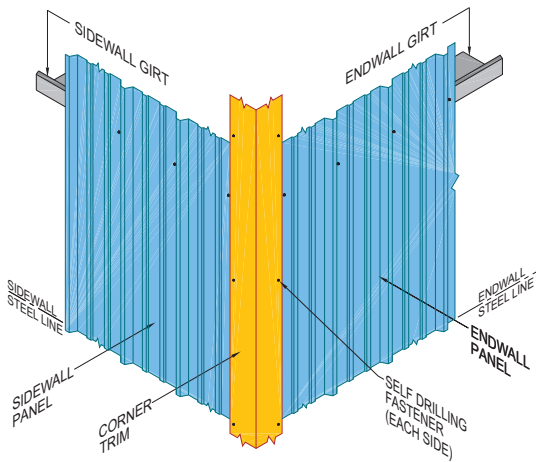

**DETAIL-7** : OUTSIDE CORNER TRIM

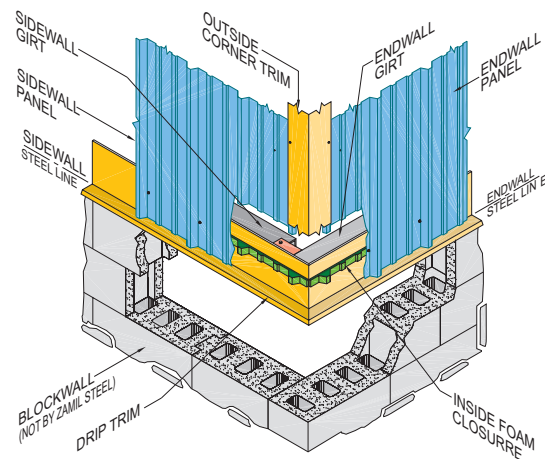

**DETAIL-8** : OUTSIDE CORNER TRIM AND DRIP TRIM ABOVE BLOCKWALL

A proper roof drainage system is essential for prolonging the life of the roof system of a pre-engineered steel building. It must be adequately designed to prevent water overflow over the sides of the building.

The integrity of a roof drainage system is influenced by the design of its **gutters** and **downspouts** and by the proper spacing of the downspouts.

A gutter is a coldformed “channel shaped” member designed to carry water from the roof of the building to the downspouts. There are two types of gutters: *eave gutters* and *valley gutters*. Valley gutters are normally located between two adjacent buildings, having equal or unequal eave heights. Eave gutters are uniquely shaped to create a distinctive look along the eave of the building.

A downspout is a hollow cold-formed section used to carry the water from the roof gutter to the ground or to a storm drainage system. Downspouts have fluted sides that add stiffness to their shape.

Internal downspouts for valley gutters are not supplied by Zamil Steel but can be provided upon request. Consult a Zamil Steel representative nearest you.



Gutters and Downspouts			
Roof Drainage Component	Material	Maximum Length (mm)	Accessories
<b>Eave gutters</b>	0.5 mm thick (nominal) pre-painted Zinalume coils available in all standard panel colors	5700	End closures, gutter straps, and flowable mastic.
<b>Valley gutters</b>	1.0 mm thick bare Zinalume coils	4500	End closures, valley gutter supports, splice plates, and double bead mastic.
<b>Downspouts</b>	0.5 mm thick (nominal) pre-painted Zinalume coils available in all standard panel colors.	5700	Downspout straps, elbows, and shoes.

The design of a roof drainage system is determined by two factors: The *gutter capacity* and the *downspout capacity*.

The following formulae determine the downspout spacing ( $D_s$ ) in a building based on gutter capacity or downspout capacity. The smaller computed value of  $D_s$  is used in the final design.

1. The following formula derived from the Copper Development Association Inc. is used to calculate the required downspout spacing ( $D_s$ ) based on gutter capacity.

$$D_s = 19 (B)^{\frac{28}{13}} \times M^{\frac{16}{13}} \times \left[ \frac{334,500}{(C \times W \times I)} \right]^{\frac{10}{13}}$$

where,

- $D_s$  = downspout spacing in (m)
- B = average width of gutter in (m)
- M = depth/width ratio of gutter
- W = width of area being drained for buildings using in (m)
- A = area of downspout in (cm<sup>2</sup>)
- I = maximum rainfall intensity  
= 150 mm per hour
- C = roof slope constant
  - = 1.00 for roof slope from 0.0/10 to 2.0/10
  - = 1.10 for roof slope from 2.1/10 to 5.4/10
  - = 1.20 for roof slope from 5.5/10 to 8.2/10
  - = 1.30 for roof slope 8.3/10 and higher

2. The following formula is used to determine the downspout spacing ( $D_s$ ) based on the downspouts capacity.

$$D_s = \frac{440 A}{(C \times W \times I)}$$

**Example:**

Consider a 36 m Clear Span building having a roof slope of 0.5/10 (C=1.0) and I = 150 mm/h.

From the standard eave gutter and downspout data on the following page, M = 154/170 = 0.91 ; and A = 73 x 105 = 76.65 cm<sup>2</sup>.

- Based on gutter capacity:

$$D_s = 19 (0.17)^{\frac{28}{13}} \times (0.91)^{\frac{16}{13}} \times \left[ \frac{334,500}{(1 \times (36/2) \times 150)} \right]^{\frac{10}{13}}$$

$$= 15.1 \text{ m}$$

- Based on downspout capacity.

$$D_s = \frac{440 \times 76.65}{(1 \times (36/2) \times 150)}$$

$$= 12.5 \text{ m}$$

- Use 12.0 m downspout spacing along the sidewalls.

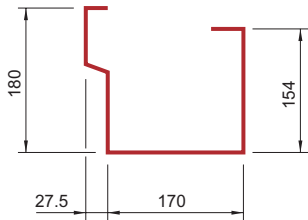

OASIS EAVE GUTTER

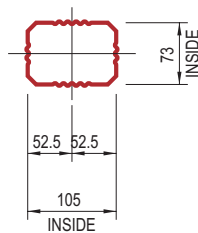

DOWNSPOUT

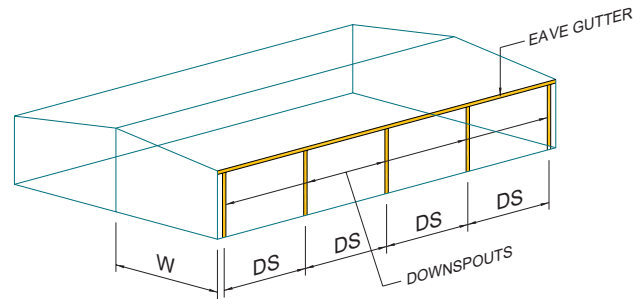

LOCATION OF EAVE GUTTER AND DOWNSPOUTS

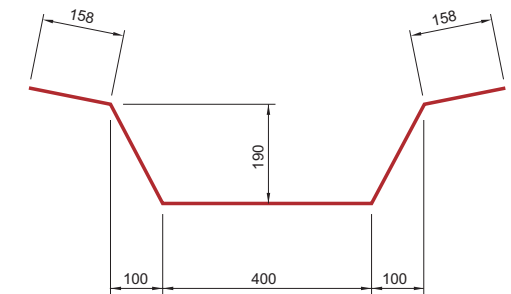
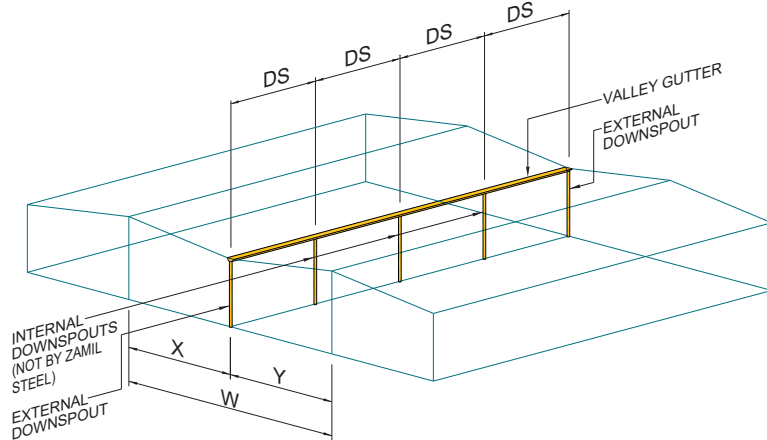

VALLEY GUTTER FOR BLDGS. WITH COMMON EAVE HEIGHTS

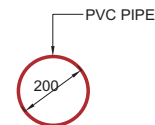

RECOMMENDED VALLEY GUTTER DOWNSPOUT (INTERNAL DOWNSPOUTS NOT BY ZAMIL STEEL)

LOCATION OF VALLEY GUTTER AND DOWNSPOUTS IN ADJACENT BLDGS. WITH COMMON EAVE HEIGHTS

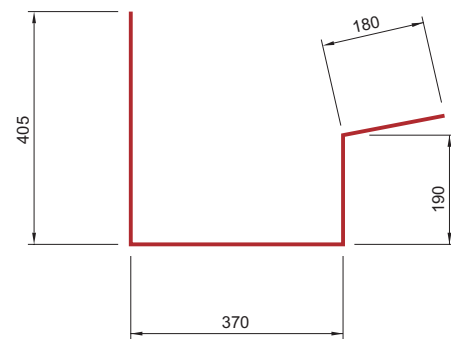
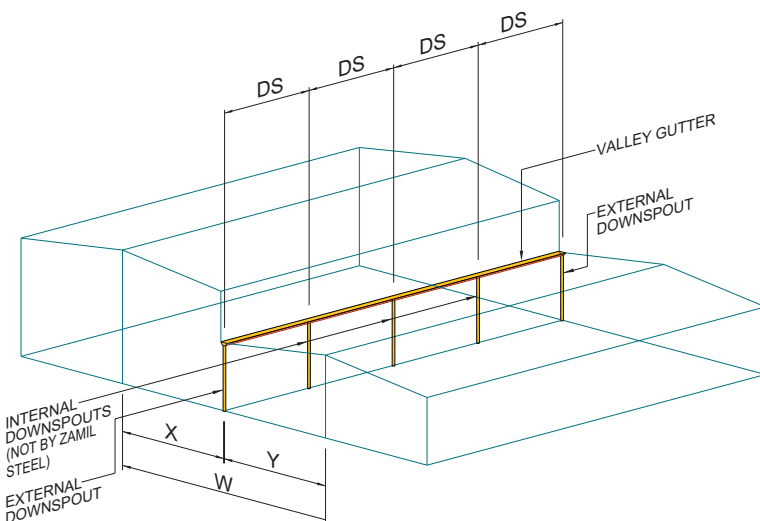

VALLEY GUTTER FOR HIGH/LOW BLDGS.



RECOMMENDED VALLEY GUTTER DOWNSPOUT (INTERNAL DOWNSPOUTS NOT BY ZAMIL STEEL)

LOCATION OF VALLEY GUTTER AND DOWNSPOUTS IN ADJACENT BLDGS. WITH DIFFERENT EAVE HEIGHTS

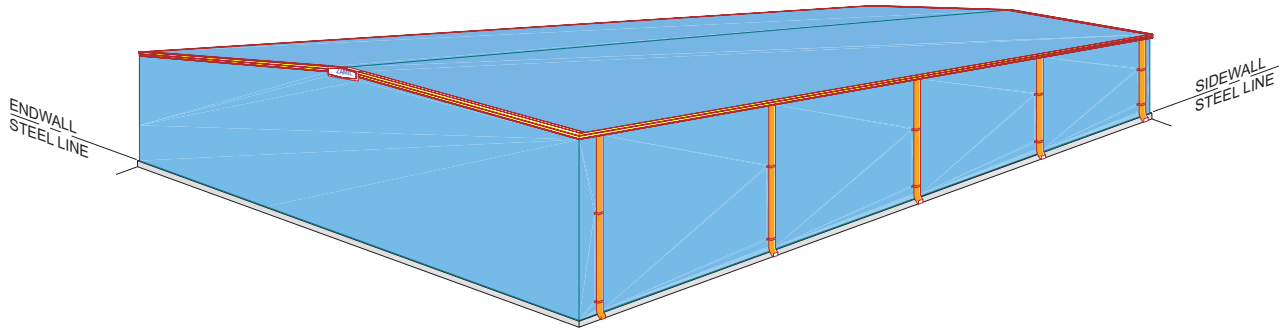

**ISOMETRIC** : GUTTER AND DOWNSPOUTS AT SIDEWALL

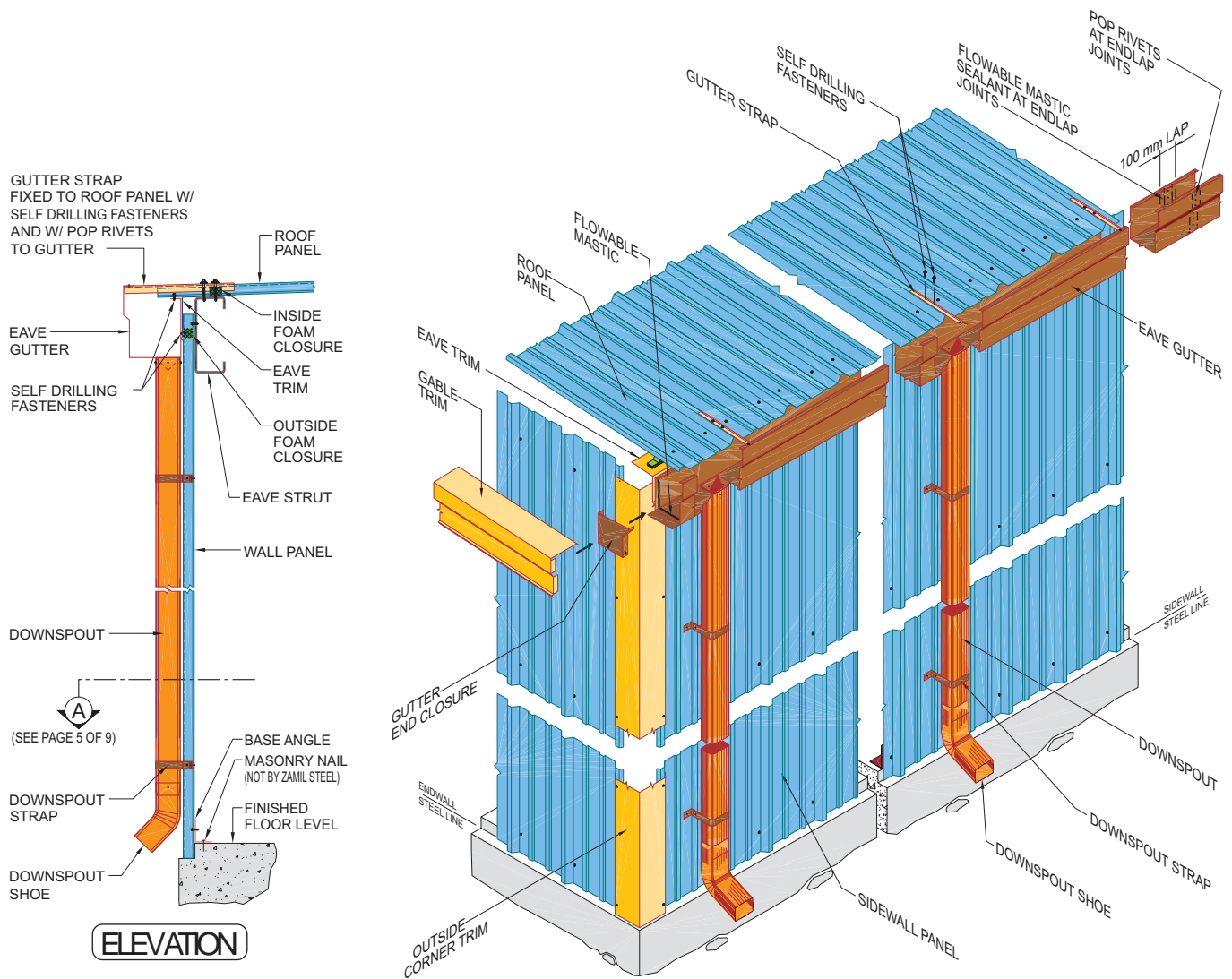

**ISOMETRIC** : GUTTER AND DOWNSPOUTS AT FULLY SHEETED SIDEWALL



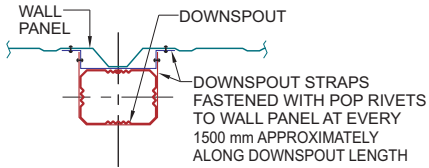

**SECTION-A**

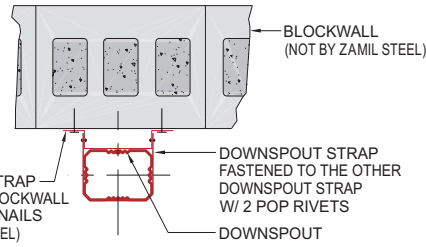

**SECTION-B**

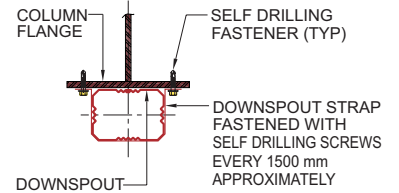

**SECTION-C**

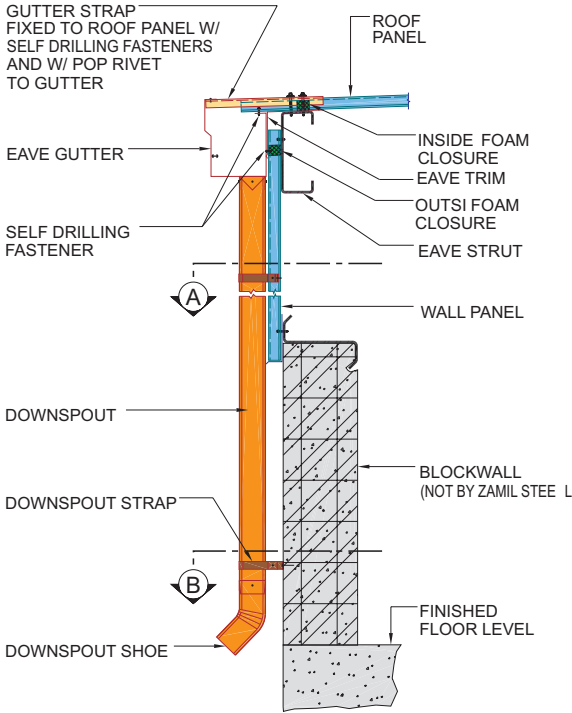

**ELEVATION** : GUTTER AND DOWNSPOUT AT PARTIALLY SHD. SIDEWALL W/BLOCKWALL

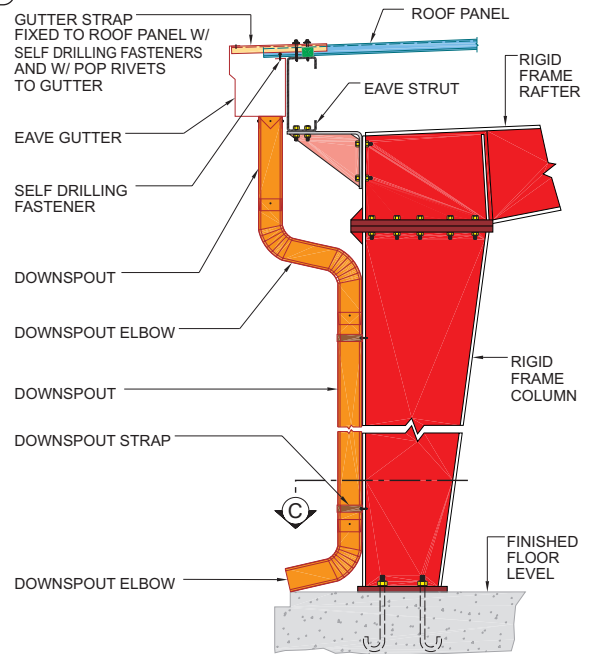

**ELEVATION** : GUTTER AND DOWNSPOUT AT RIGID FRAME OPEN SIDEWALL

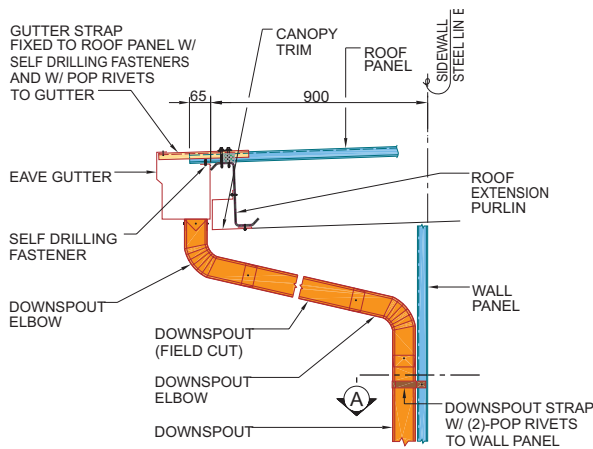

**ELEVATION** : GUTTER AND DOWNSPOUT AT 900mm SIDEWALL ROOF EXTENSION

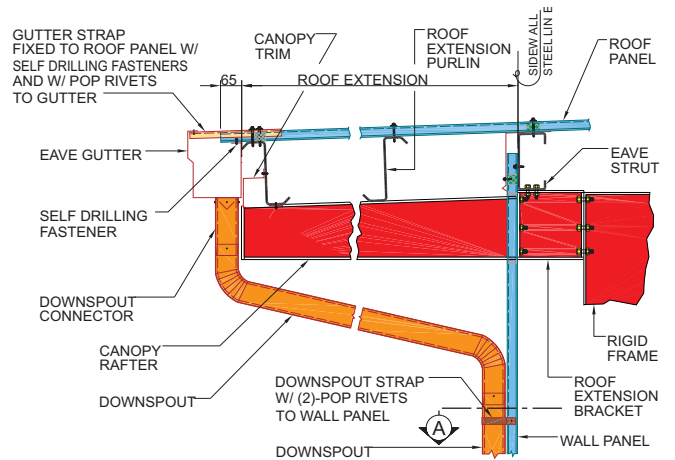

**ELEVATION** : GUTTER AND DOWNSPOUT AT SIDEWALL ROOF EXTENSION

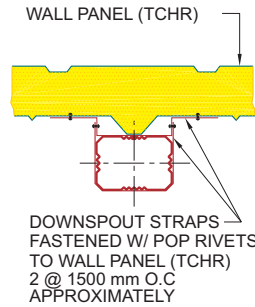
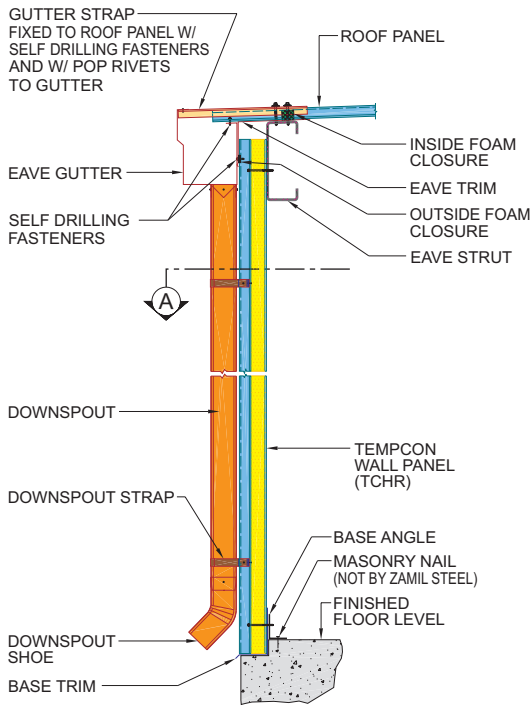

SECTION-A

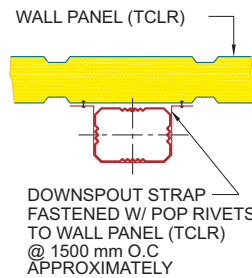

SECTION-B

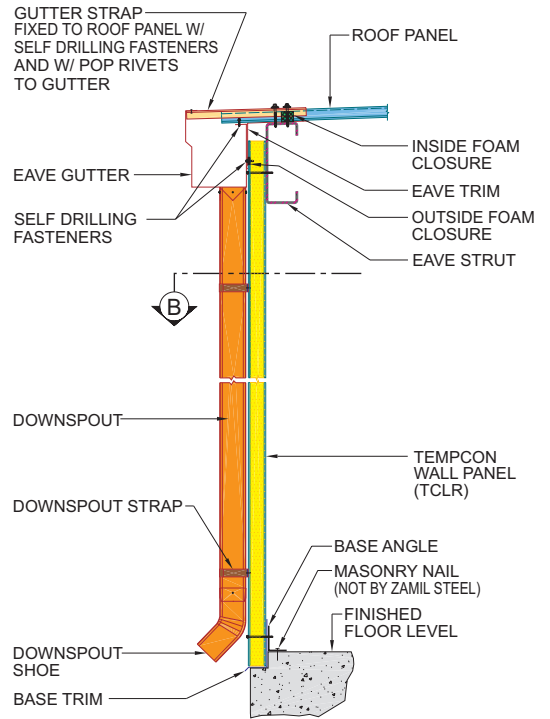

ELEVATION : GUTTER AND DOWNSPOUT AT FULLY (TCHR) SHEETED SIDEWALL

ELEVATION : GUTTER AND DOWNSPOUT AT FULLY (TCLR) SHEETED SIDEWALL

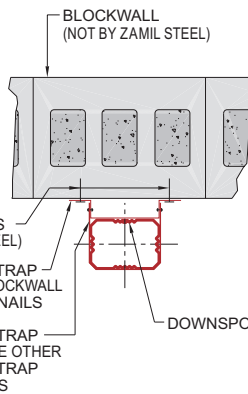
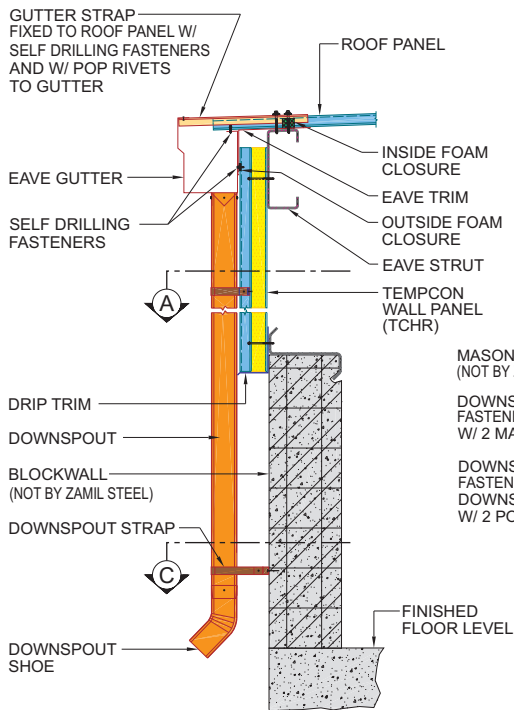

SECTION-C

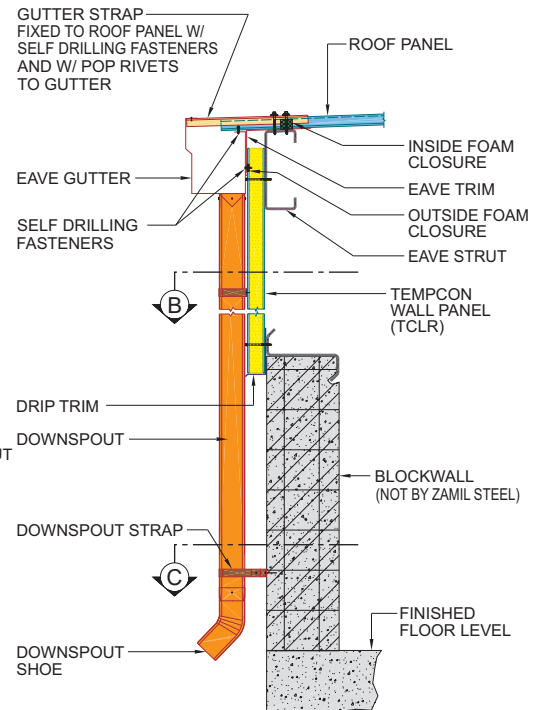

ELEVATION : GUTTER AND DOWNSPOUT AT PARTIALLY (TCHR) SHTD. SIDEWALL W/BLOCKWALL

ELEVATION : GUTTER AND DOWNSPOUT AT PARTIALLY (TCLR) SHTD. SIDEWALL W/BLOCKWALL

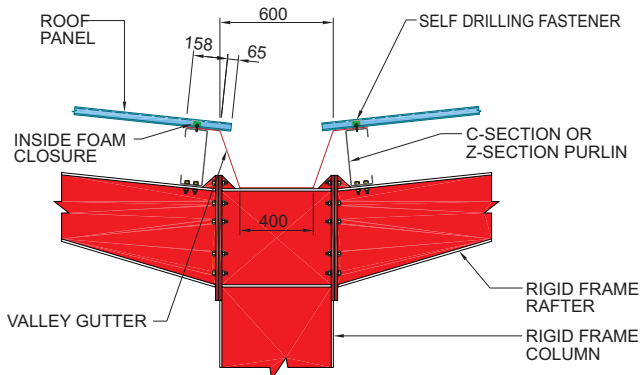

**SECTION-1** : VALLEY GUTTER AT MULTI-GABLE BLDG.

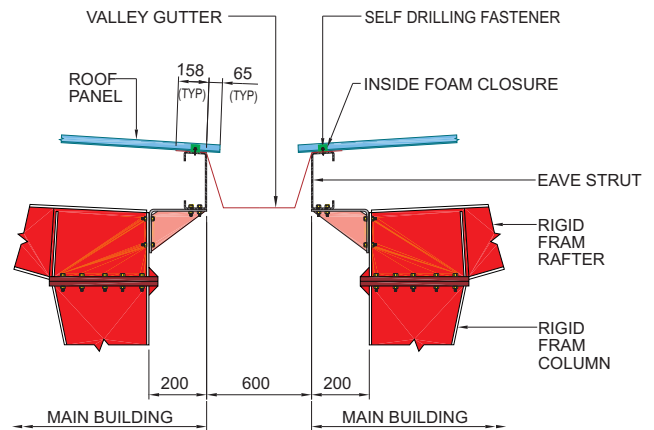

**SECTION-1** : VALLEY GUTTER AT EAVE OF BLDGS. WITH COMMON EAVE HEIGHTS

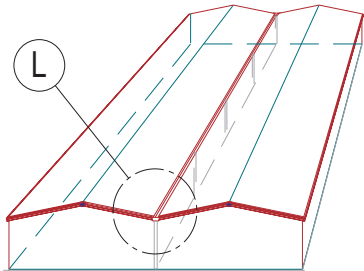

**ISOMETRIC** : VALLEY GUTTER LOCATION

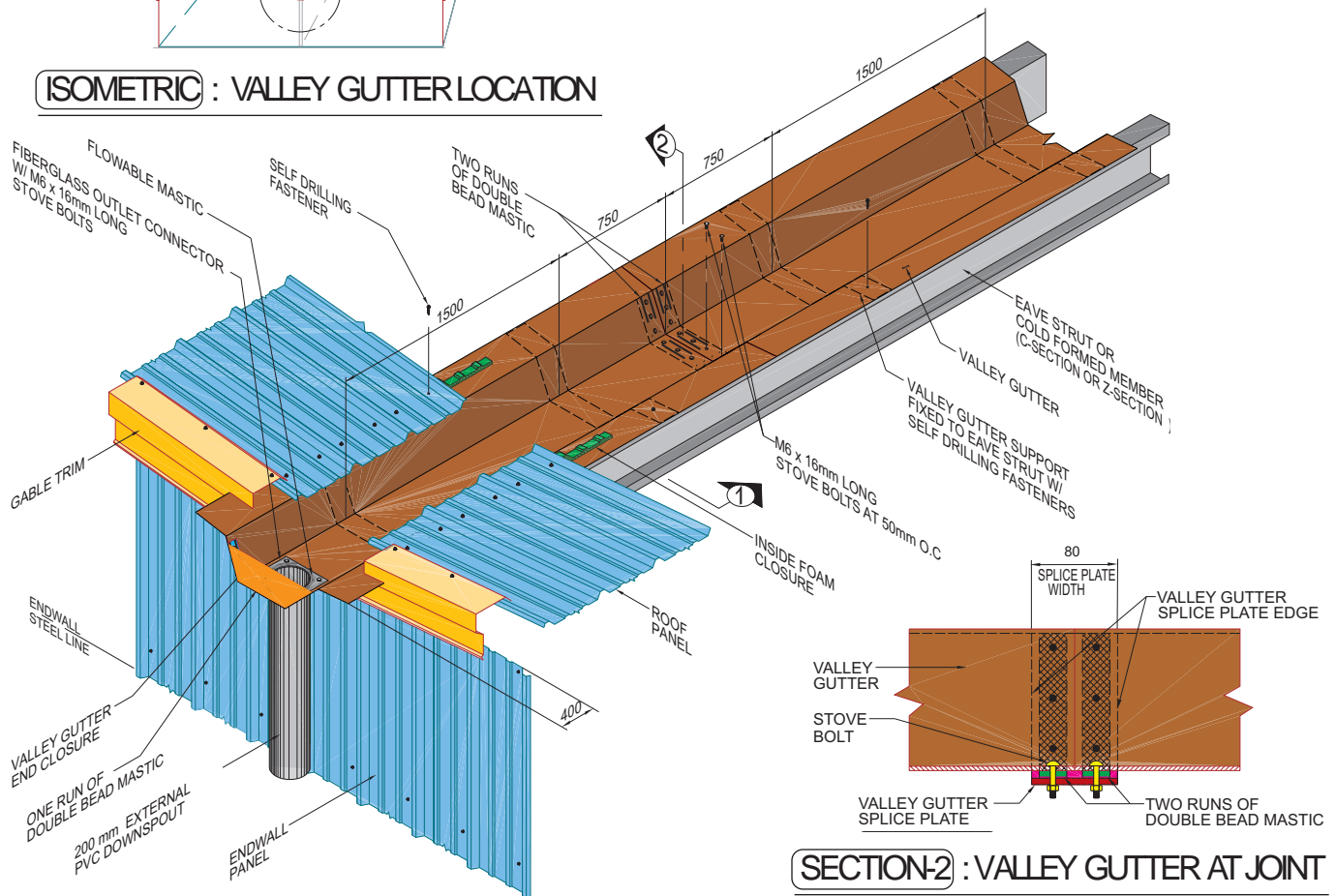

**SECTION-2** : VALLEY GUTTER AT JOINT

**DETAIL-L** : VALLEY GUTTER DETAIL AT MULTI-GABLE OF BLDGS. WITH COMMON EAVE HEIGHTS

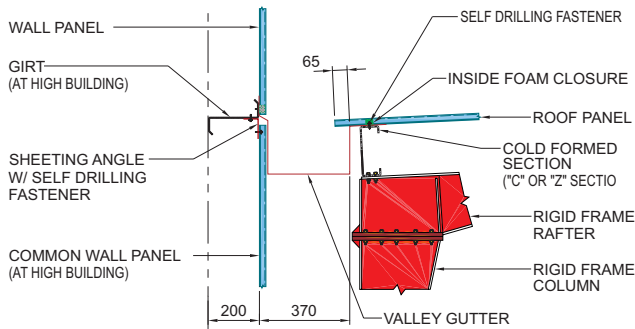

SECTION-3 : VALLEY GUTTER W/COMMON WALL SHEETING AT HIGH BLDG.

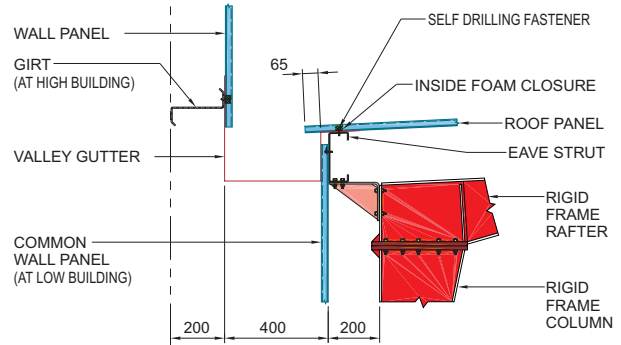

SECTION-3 : VALLEY GUTTER W/COMMON WALL SHEETING AT LOW BLDG.

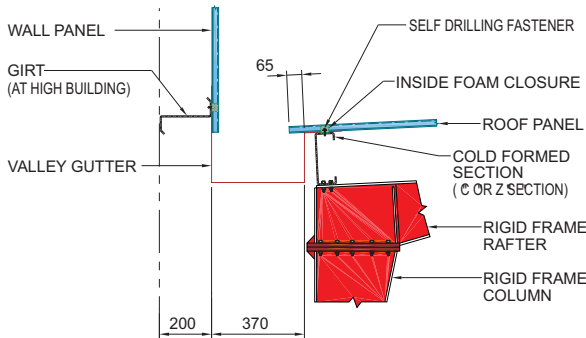

SECTION-3 : VALLEY GUTTER W/NO SHEETING AT COMMON WALL

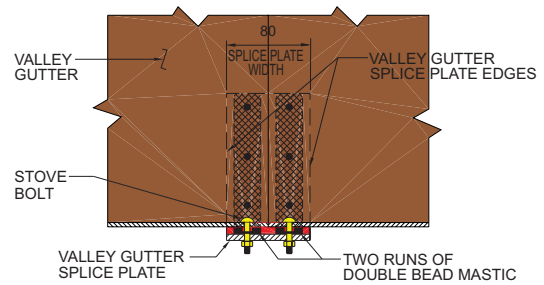

SECTION-4 : VALLEY GUTTER AT JOINT

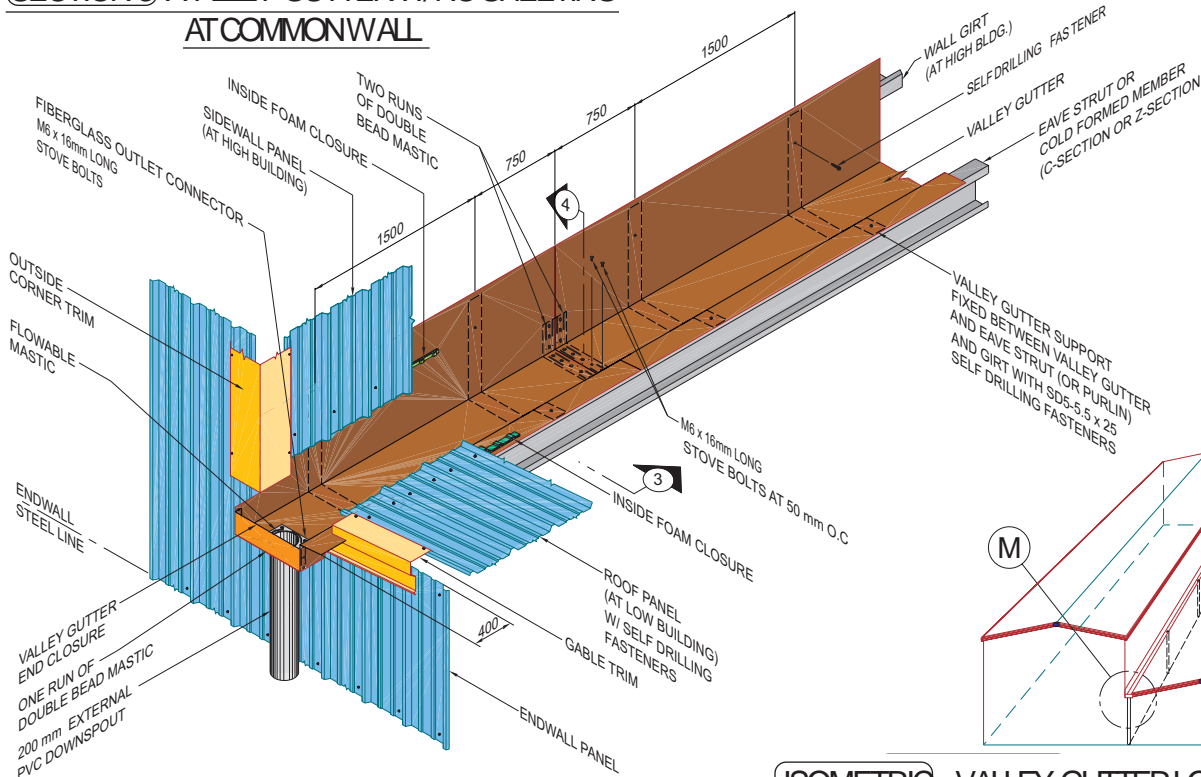

DETAIL-M : VALLEY GUTTER DETAIL AT COMMON EAVE OF BLDGS. WITH DIFFERENT EAVE HEIGHTS

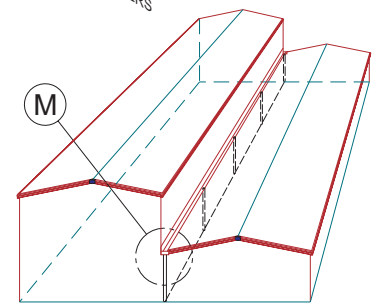

ISOMETRIC : VALLEY GUTTER LOCATION

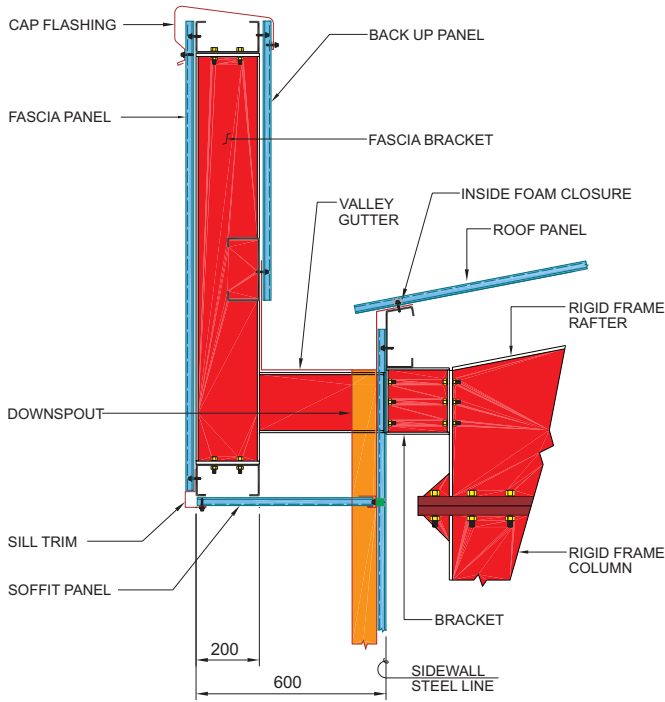

VALLEY GUTTER AT VERTICAL FASCIA

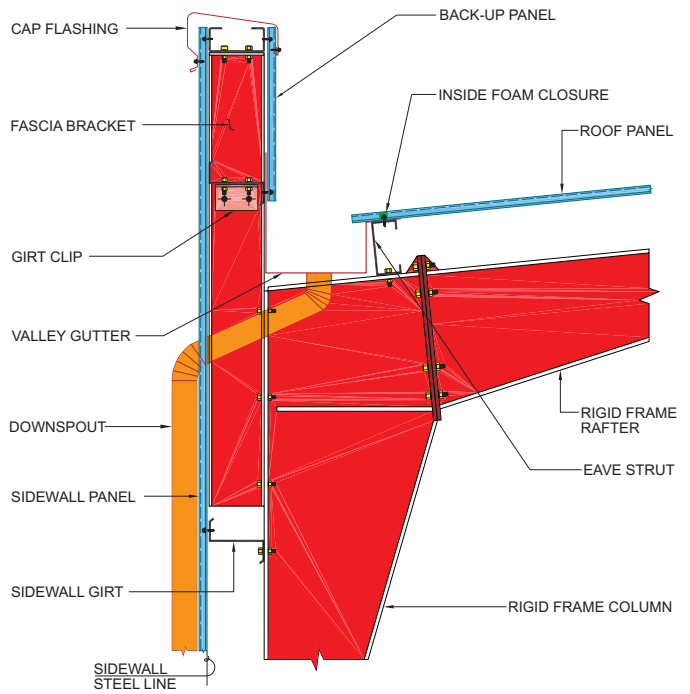

VALLEY GUTTER AT PARAPET FASCIA

**SECTION :** VALLEY GUTTER AND DOWNSPOUT AT FASCIA

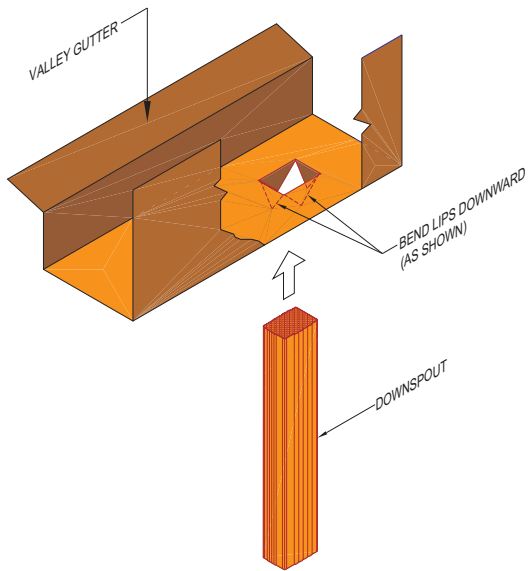

VALLEY GUTTER AND DOWNSPOUT CONNECTION AT VERTICAL FASCIA

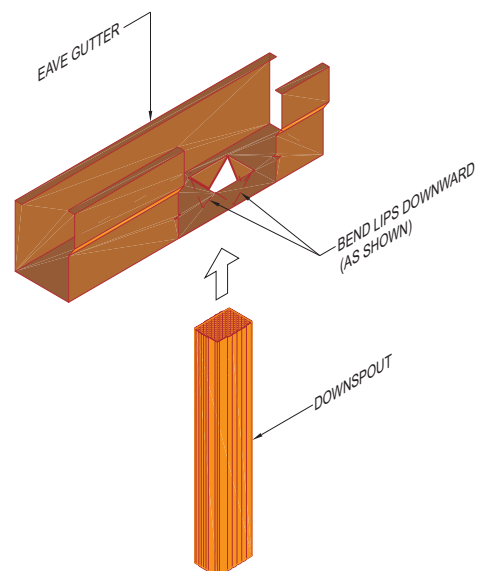

EAVE GUTTER AND DOWNSPOUT CONNECTION AT BUILDING EAVE

NOTE: INSERT DOWNSPOUT INTO GUTTER AS SHOWN. APPLY FLOWABLE MASTIC ALL AROUND DOWNSPOUT EDGE AND ONE POP RIVET AT EACH SIDE.



# OTHER STRUCTURAL SUBSYSTEMS

C  
H  
A  
P  
T  
E  
R

1 1

# Other Structural Subsystems

11.1	General .....	241
11.2	Roof Extensions .....	242
11.3	Canopies .....	251
11.4	Fascias .....	255
11.5	Partitions .....	262
11.6	Cranes .....	267
11.7	Roof Monitors .....	274



Zamil Steel offers 'other structural subsystems' than those presented in **chapter 7**. The following subsystems are complementary to the primary building system. They add a functional or aesthetic feature to the building.

- Roof extensions
- Canopies
- Fascias
- Partitions
- Cranes
- Roof monitors

These structural subsystems are described as 'other' because they are additional features to the building that have to be specified by the customer upon sending a request for quotation.



**Roof extensions** are continuations of the roof beyond the planes of the sidewall or endwall of a building. The primary purpose of roof extensions, whether at the sidewall or endwall, is to provide additional weather protection to the walls. They can also add aesthetic beauty to the overall physical appearance of a building.

The standard roof extensions for Zamil Steel buildings are 900 mm and 1500 mm wide for both sidewall and endwall roof extensions, respectively.

The framing of *sidewall roof extensions* may consist of built-up members, hot rolled members or cold-formed sections that are cantilevered from the building at the sidewalls. Whereas the framing of *endwall roof extensions* consists mainly of cold-formed “Z” sections which are continuous extensions of the end bay purlins and eave struts of the main building.

It is important to differentiate between sidewall roof extensions and endwall roof extensions. Whereas economical endwall roof extensions are limited in width due to the limited load capacities of “Z” sections, economical sidewall roof extensions can be designed for greater widths.

Roof extensions can be supplied with or without a *soffit*. The term soffit refers to the provision of liner panels at the underside of the roof extension framing. Soffits are used when a neat flush appearance is required under roof extensions.

Roof extensions are designed to accommodate gutters and return downspouts.

The roof panels on roof extensions are a continuation of the roof panels of the main building.



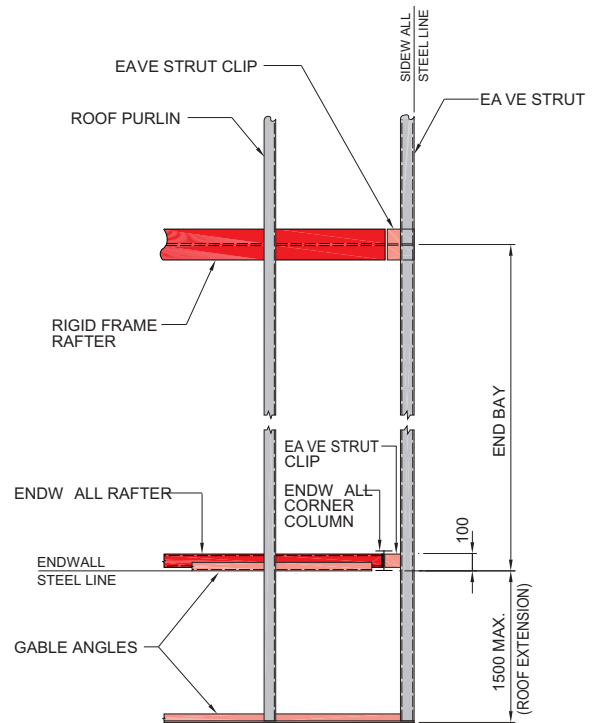
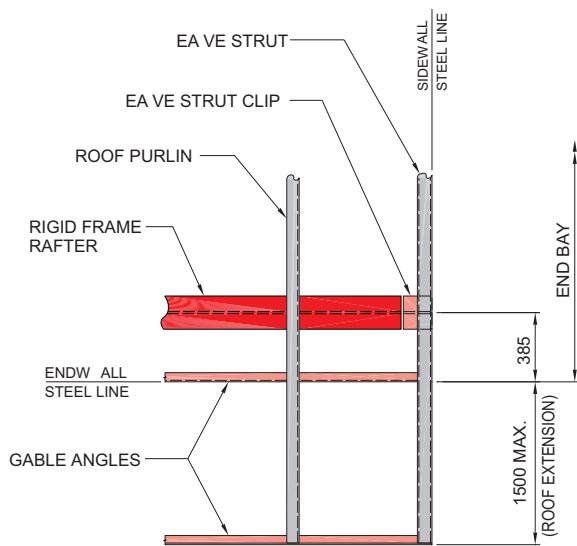
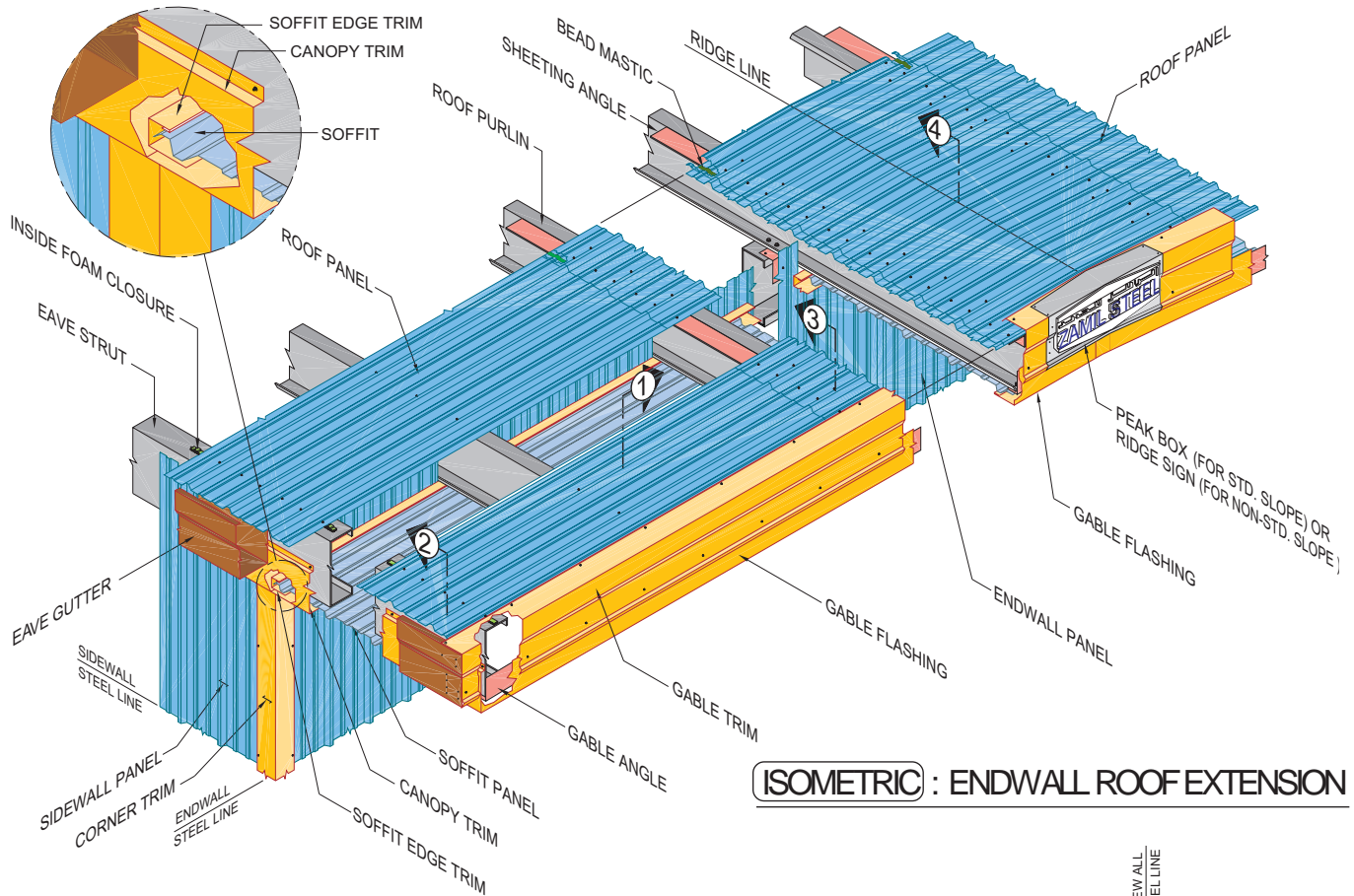

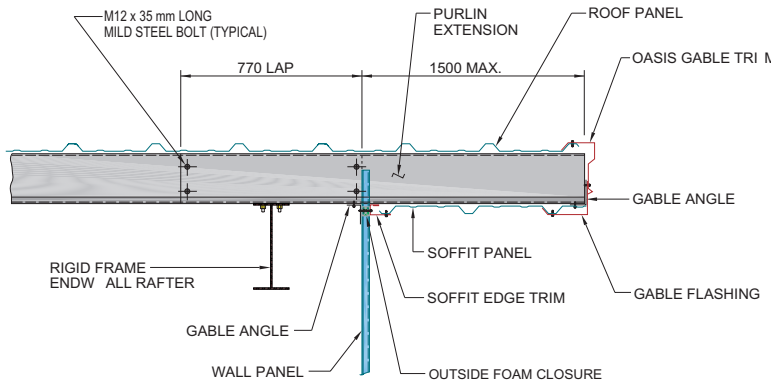

**ROOF EXTENSION WITH SOFFIT PANEL  
AT R.F. ENDWALL**

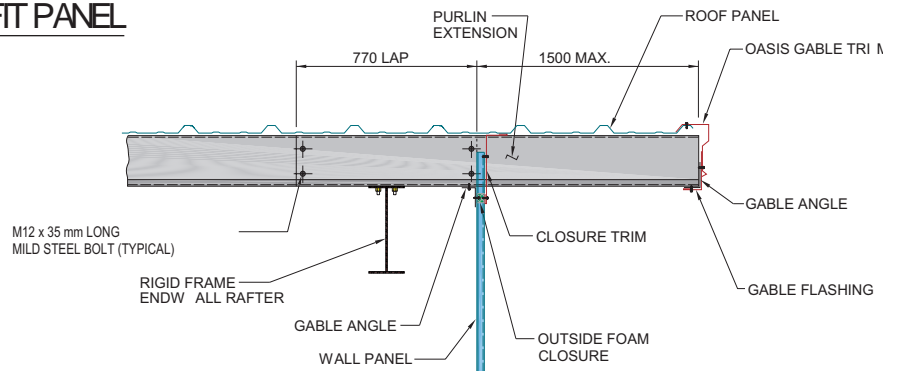

**ROOF EXTENSION WITHOUT SOFFIT  
PANEL AT R.F. ENDWALL**

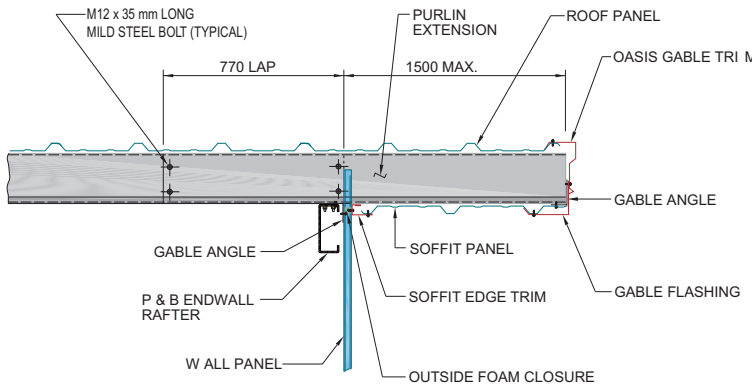

**ROOF EXTENSION WITH SOFFIT PANEL  
AT P & B ENDWALL**

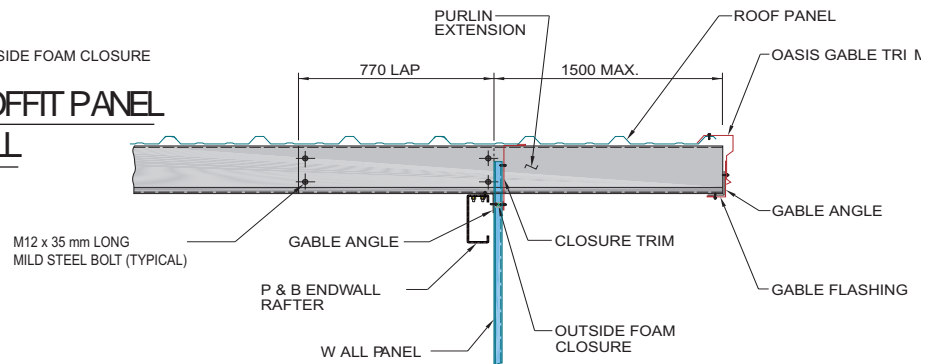

**ROOF EXTENSION WITHOUT SOFFIT  
PANEL AT P & B ENDWALL**

**SECTION-1 : ROOF EXTENSION DETAILS AT R.F. AND P&B ENDWALLS**

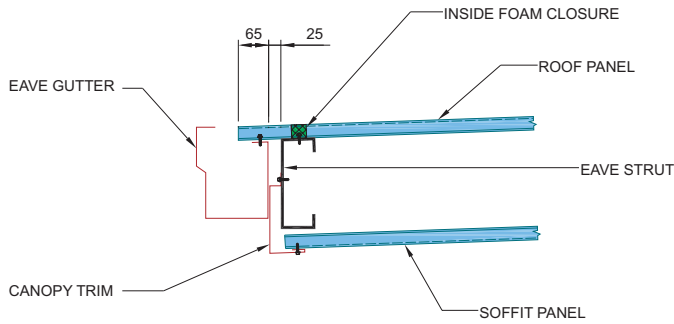

**SECTION AT EAVE WITH GUTTER AND SOFFIT PANEL**

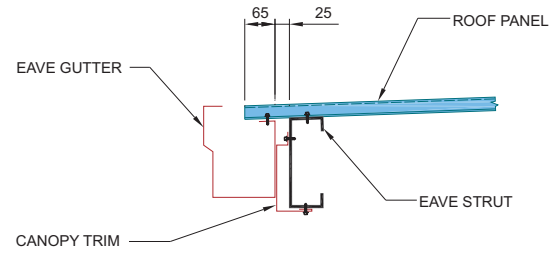

**SECTION AT EAVE WITH GUTTER AND WITHOUT SOFFIT PANEL**

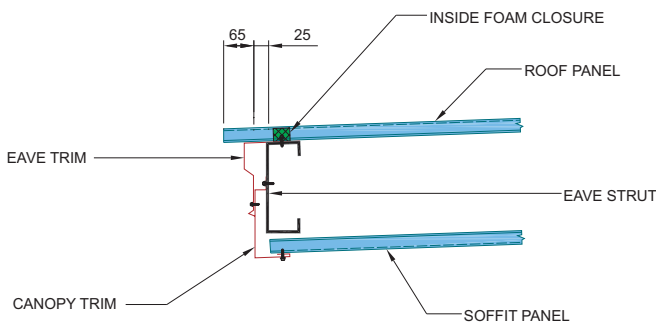

**SECTION AT EAVE WITHOUT GUTTER AND WITH SOFFIT PANEL**

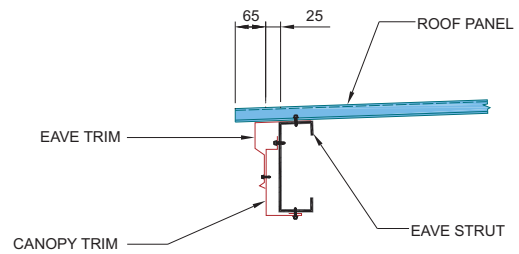

**SECTION AT EAVE WITHOUT GUTTER AND WITHOUT SOFFIT PANEL**

**SECTION-2 : SECTIONS AT EAVE**

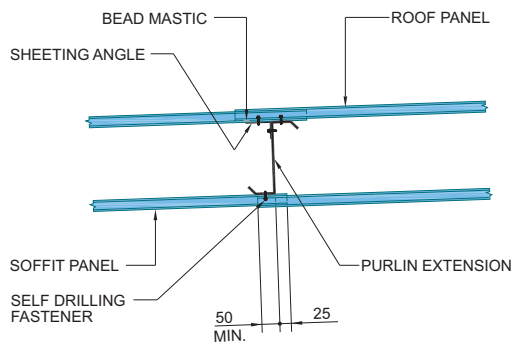

**SECTION-3 : SOFFIT ENDLAP DETAIL**

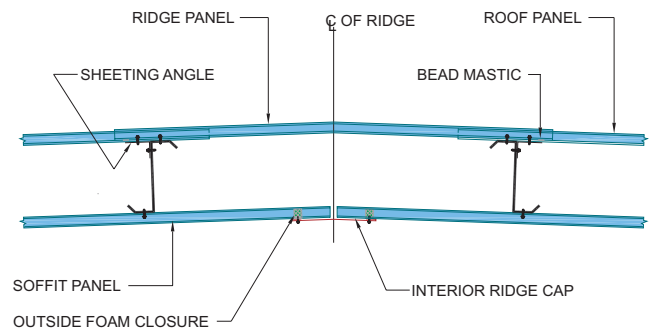

**SECTION-4 : SECTION AT RIDGE**

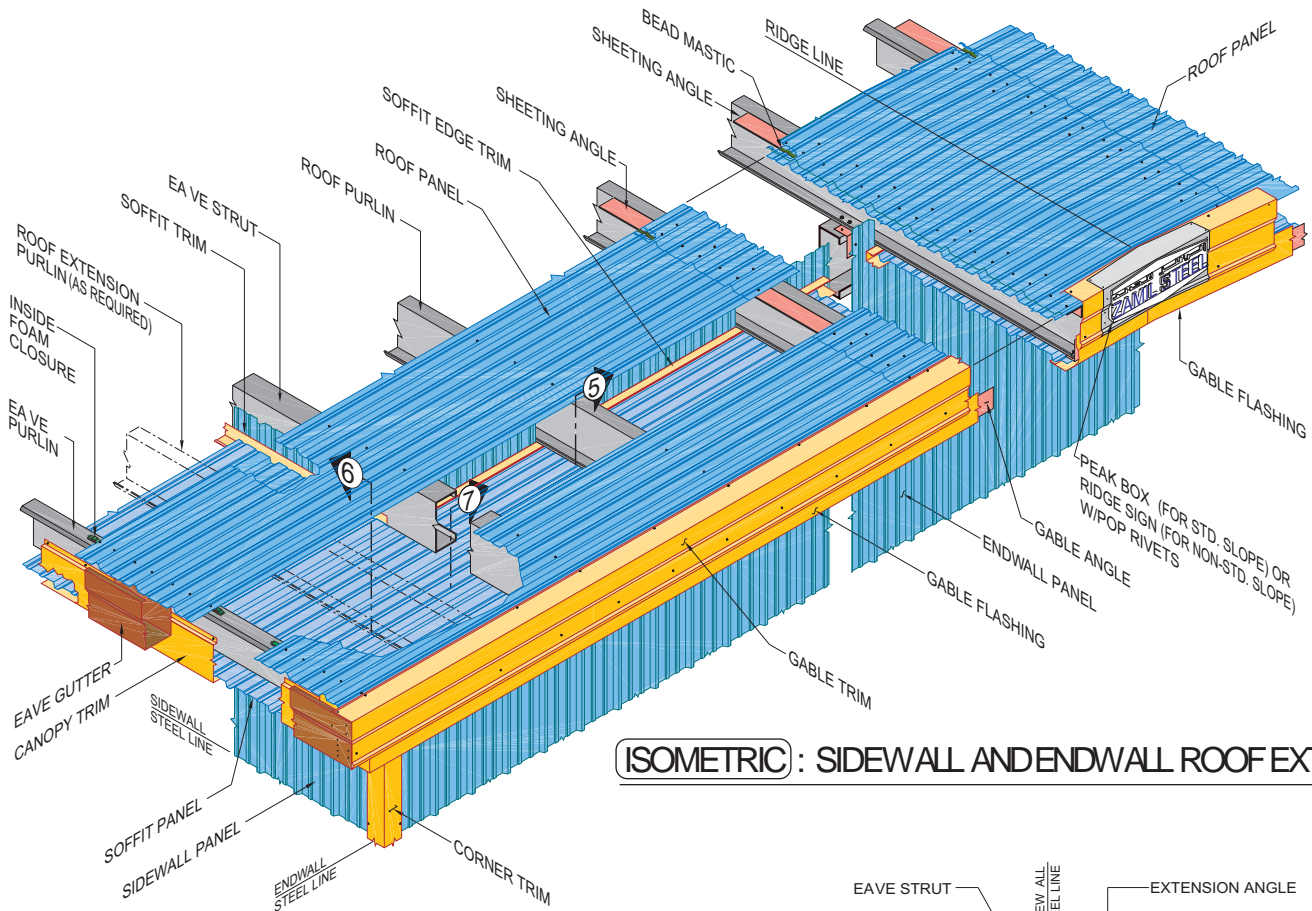

**ISOMETRIC** : SIDEWALL AND ENDWALL ROOF EXT'N

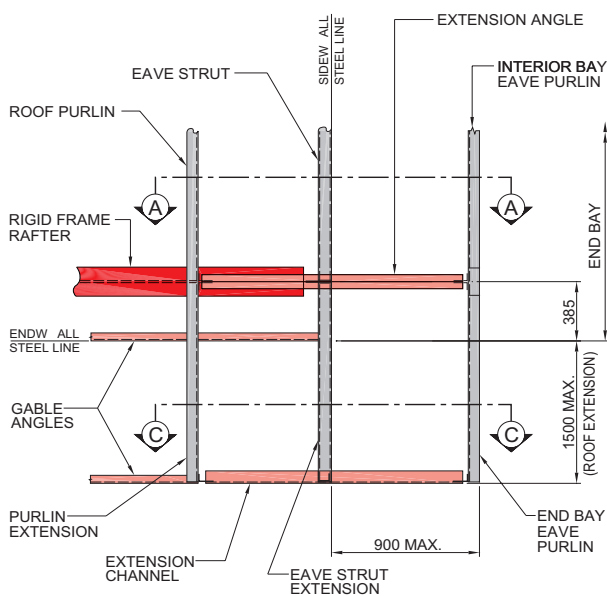

**PLAN** : SIDEWALL AND ENDWALL ROOF EXTENSION FRAMING AT R.F. ENDWALL

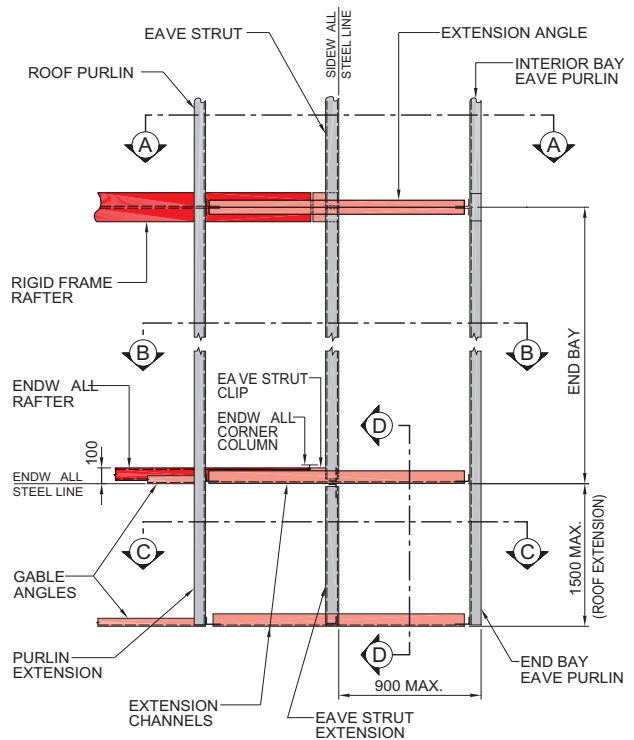

**PLAN** : SIDEWALL AND ENDWALL ROOF EXTENSION FRAMING AT P&B ENDWALL

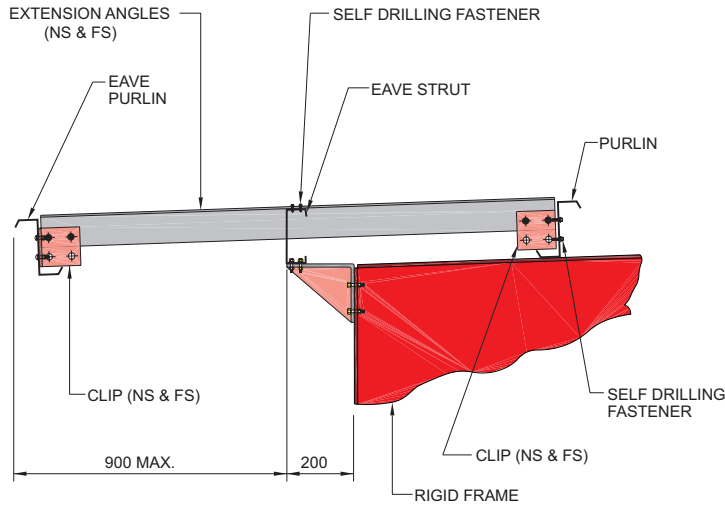

**SECTION A-A : ROOF EXTENSION AT SIDEWALL**

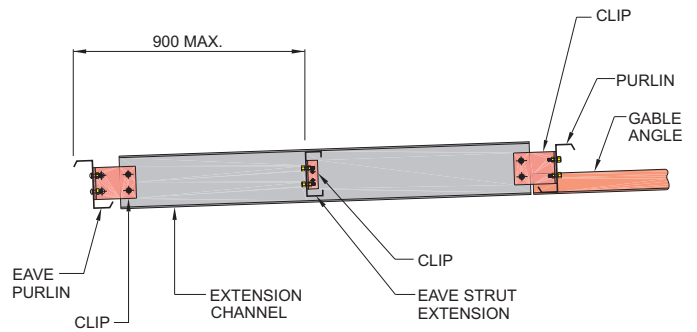

**SECTION C-C : ROOF EXTENSION AT R.F. ENDWALL**

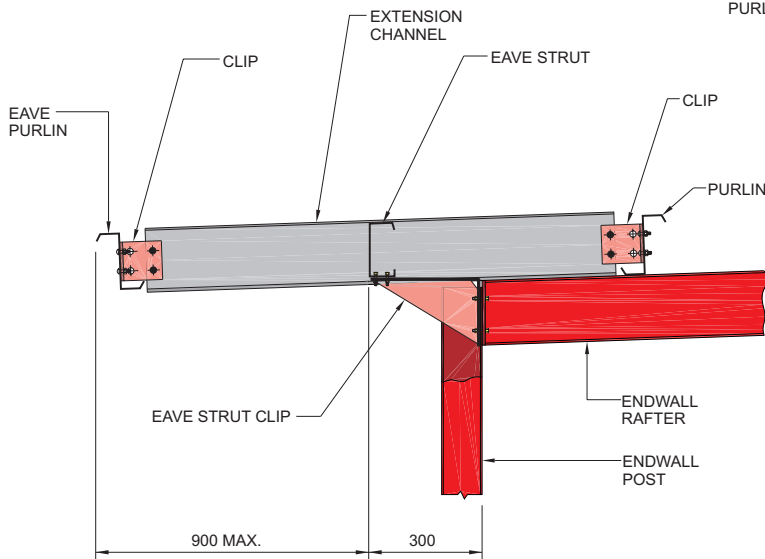

**SECTION B-B : ROOF EXTENSION AT EAVE AT P&B ENDWALL CORNER**

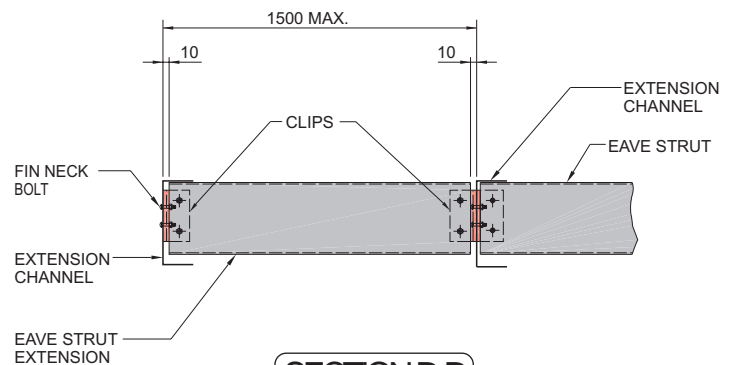

**SECTION D-D**

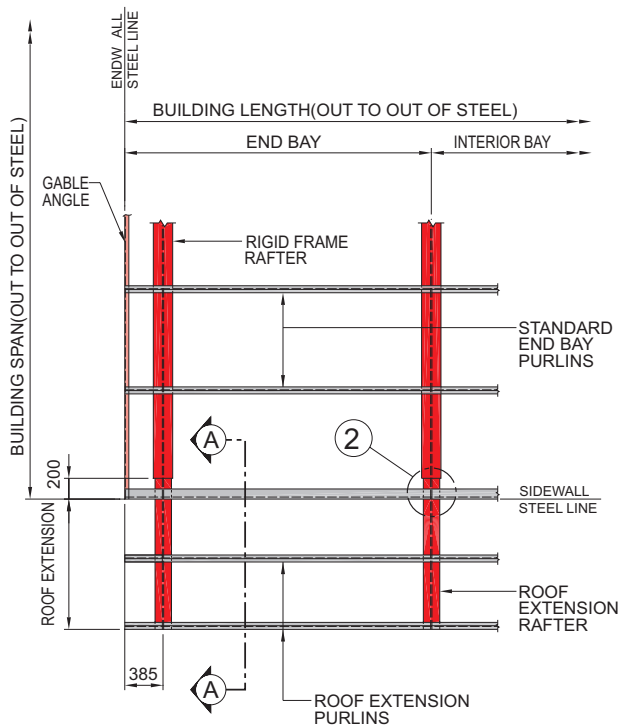

**PLAN** : SIDEWALL ROOF EXTENSION FRAMING AT R.F.

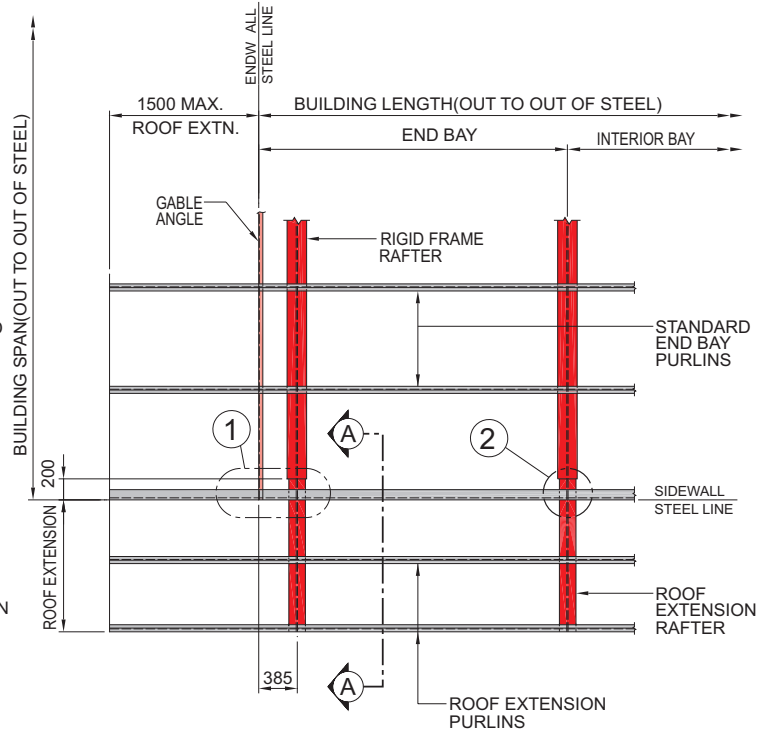

**PLAN** : SIDEWALL AND ENDWALL ROOF EXTENSION FRAMING AT R.F.

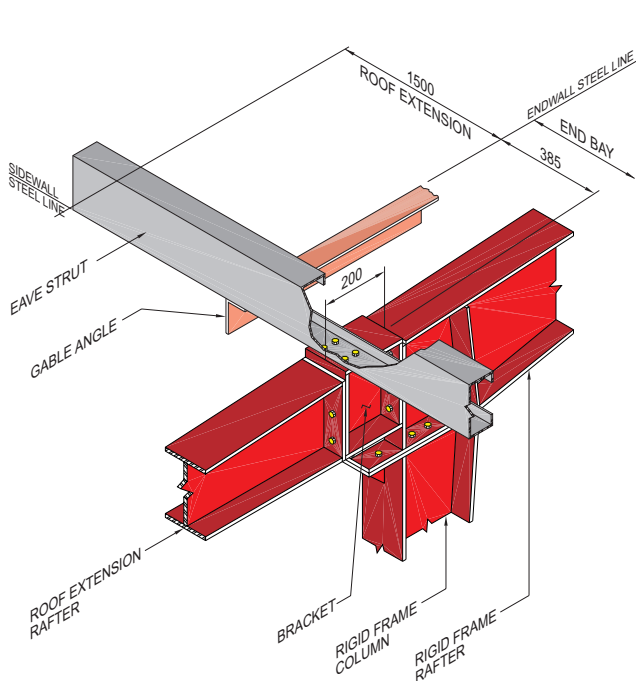

**DETAIL-1** : ROOF EXTENSION FRAMING AT EAVE AT R.F. ENDWALL CORNER

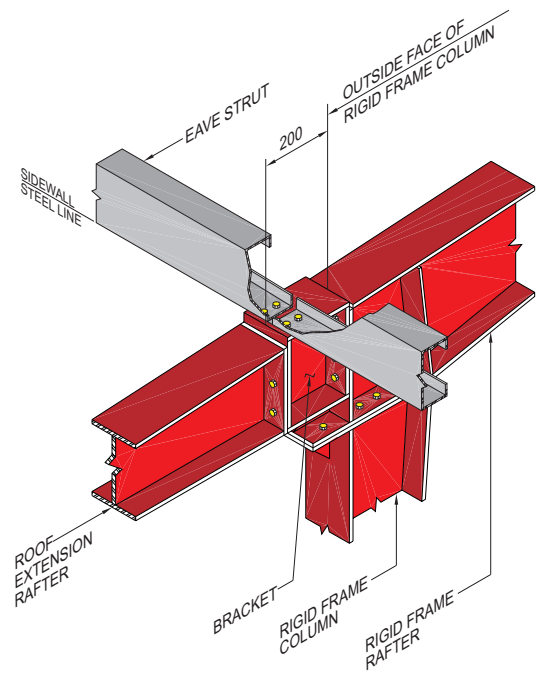

**DETAIL-2** : ROOF EXTENSION FRAMING AT EAVE AT INTERIOR BAY



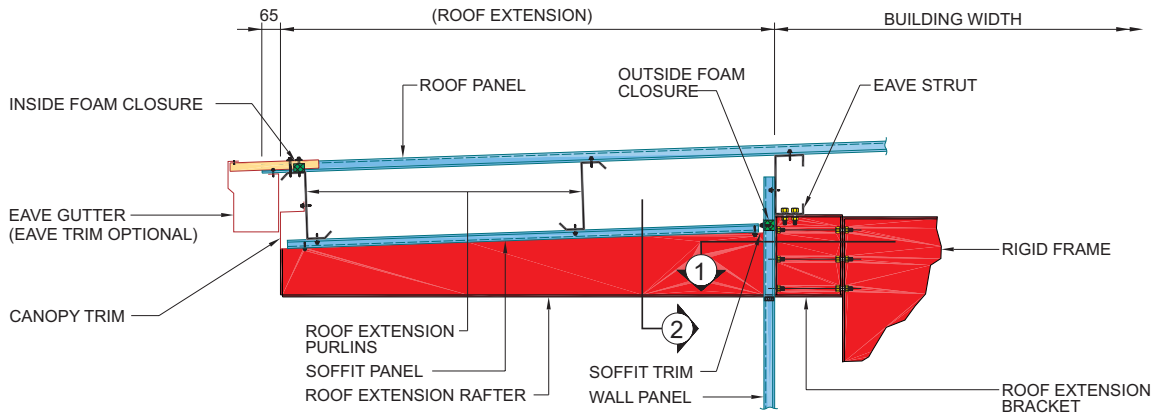

**SECTION AA : ROOF EXTENSION AT EAVE (WITH SOFFIT)**

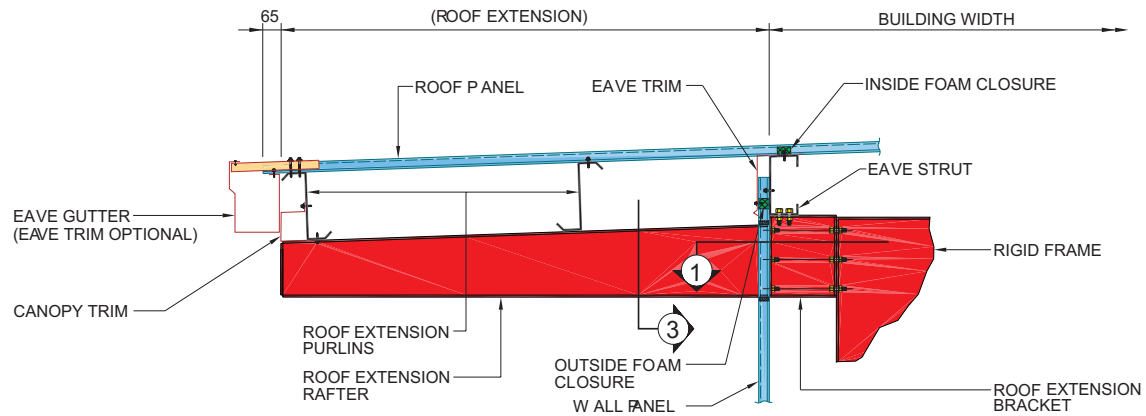

**SECTION AA : ROOF EXTENSION AT EAVE (WITHOUT SOFFIT)**

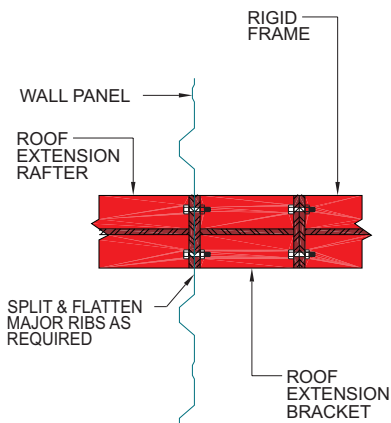

**SECTION-1**

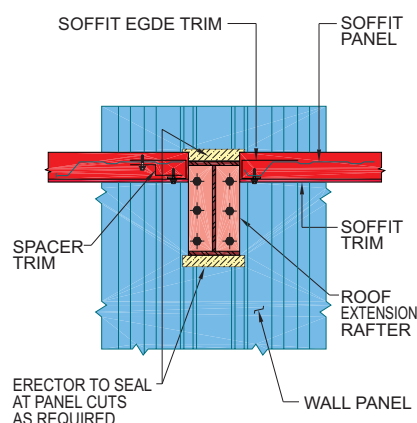

**SECTION-2**

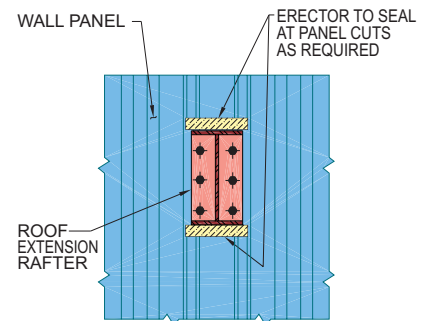

**SECTION-3**

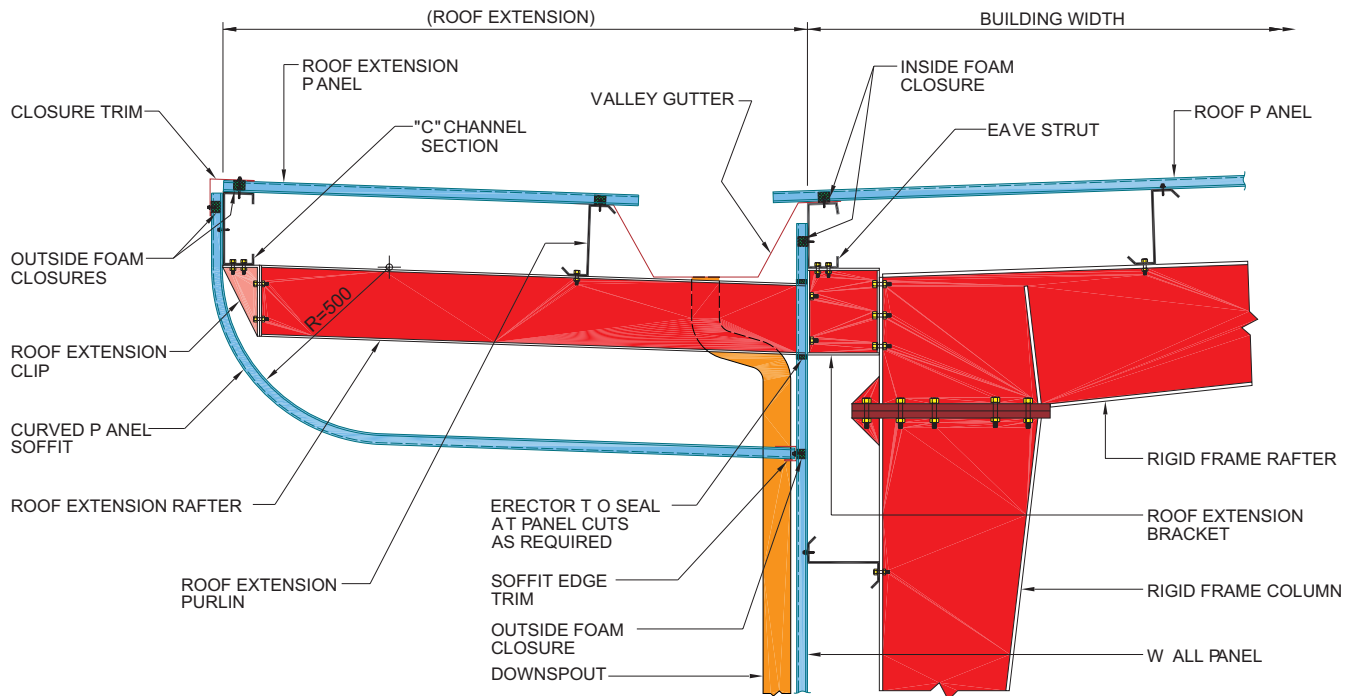

**CROSS SECTION** : ROOF EXTENSION AT EAVE  
(WITH CURVED PANEL SOFFIT AND VALLEY GUTTER)

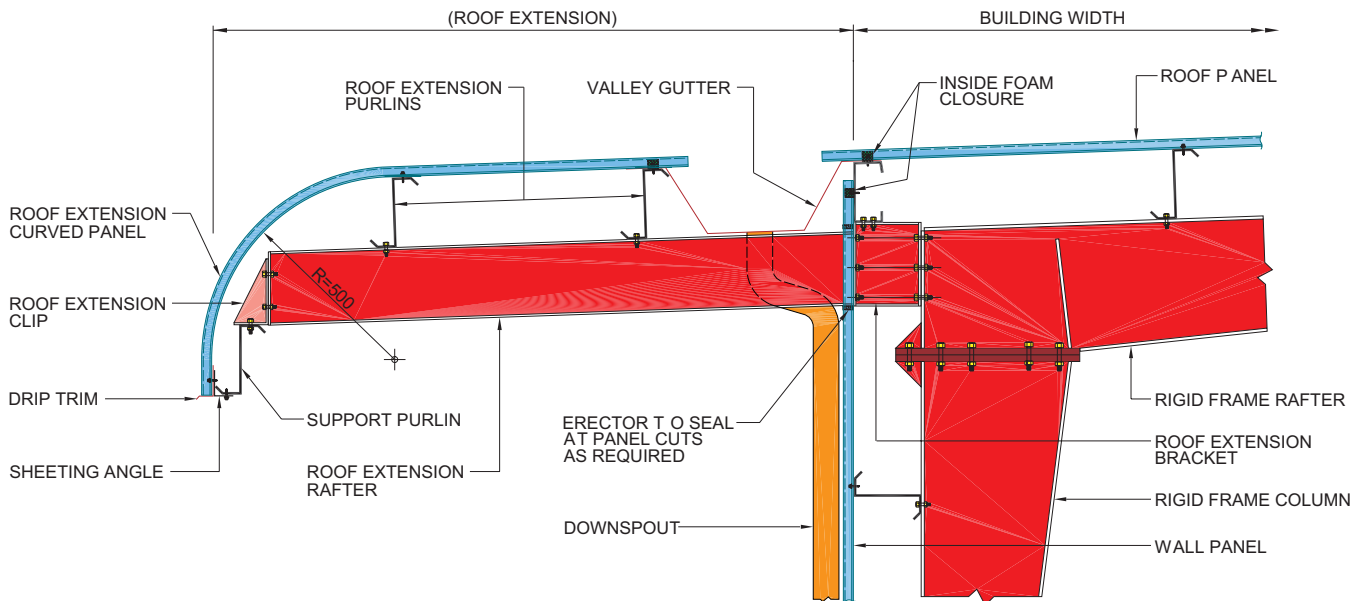

**CROSS SECTION** : ROOF EXTENSION AT EAVE  
(WITH CANOPY CURVED PANEL AND VALLEY GUTTER)

**Canopies** are narrow roof systems that cantilever (below the eave of a building) from the sidewalls and endwalls, providing various functions such as:

- A shade to block direct sunlight falling on the building walls.
- An extended covering to protect against rain in loading and unloading areas of warehouses, factories, supermarkets, shopping malls, etc.
- A cover at entrances of buildings or for car parking adjacent to building walls.

The width of a standard canopy is 1500 mm, but greater widths can easily be accommodated.

The standard Zamil Steel canopy consists of built-up tapered, hot rolled or cold-formed canopy rafters, cantilevered from the main frame columns or from the endwall columns. Rafters support 200 mm deep purlins which in turn support roof panels. The roof panels of canopies normally match the roof panels of the building to which they are attached.

Canopies may extend along the full or partial length of the sidewalls or endwalls of a building. Ideally they should start at a wall column and end at a wall column.

Canopies can be supplied with or without a *soffit*. The term soffit refers to the provision of liner panels at the underside of the canopy purlins. Soffits are used when a neat and elegant flush appearance is required under the canopy.

Canopies are designed to accommodate flashing and gutters of the same material as used on the main building.



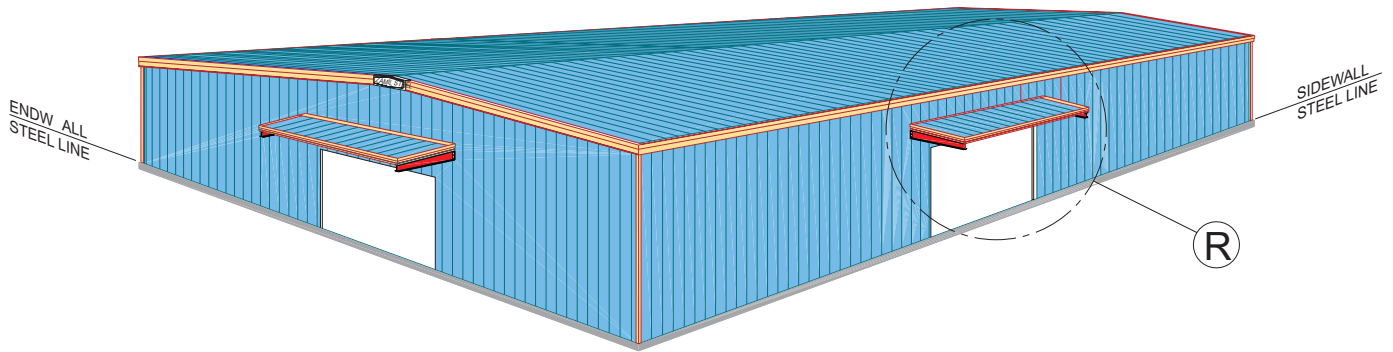

**ISOMETRIC** : CANOPIES BELOW EAVE AT ENDWALL AND SIDEWALL

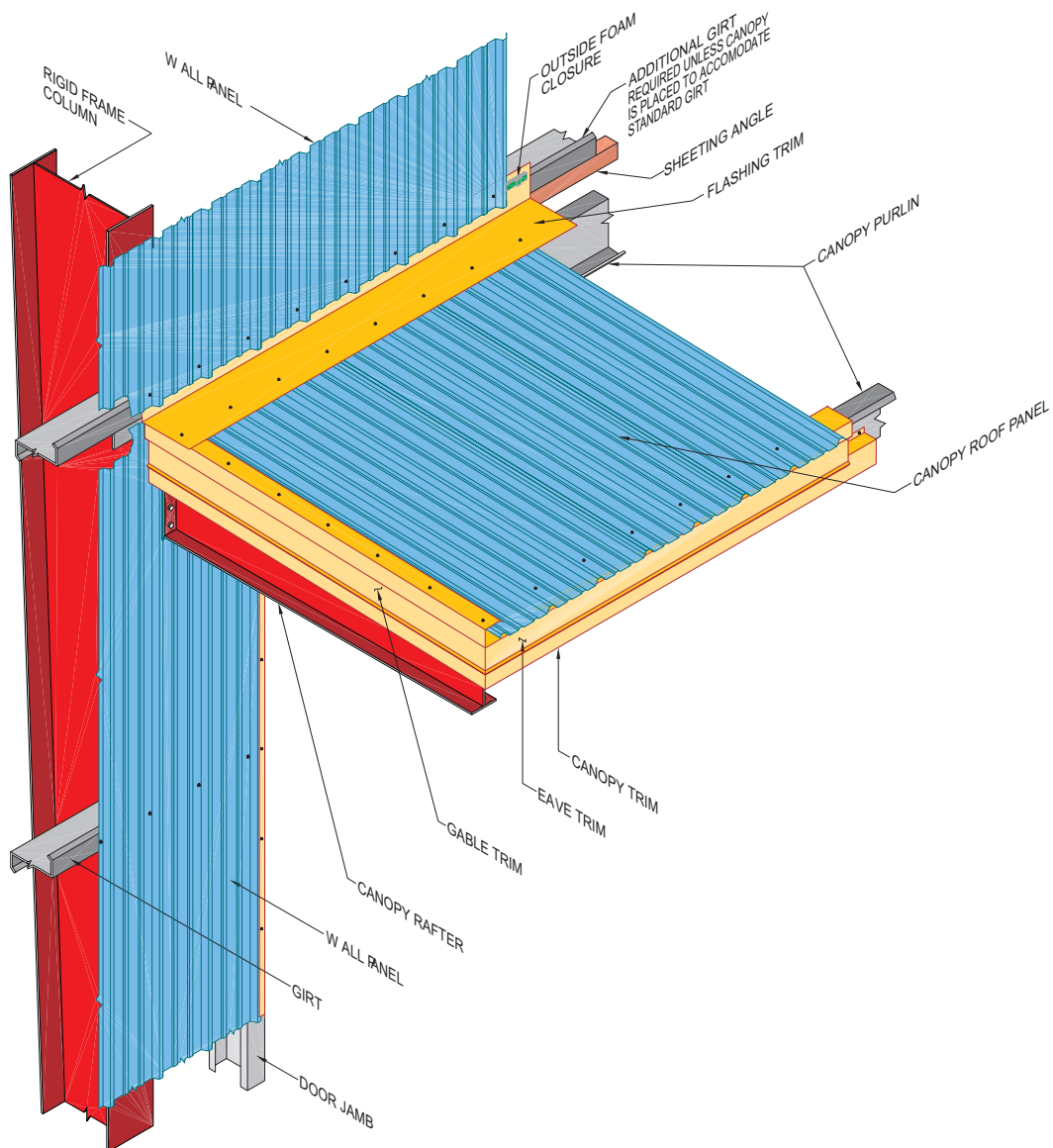

**DETAIL-R** : CANOPY SHEETING DETAIL

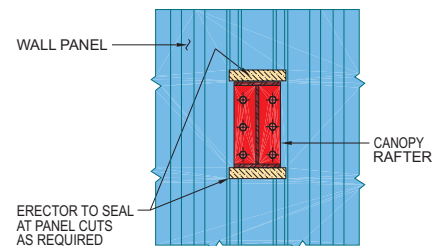
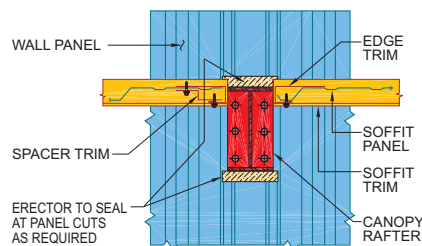
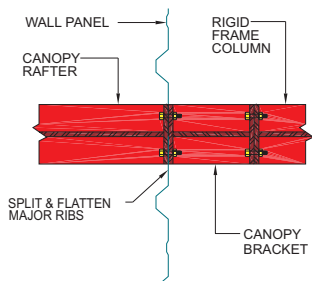
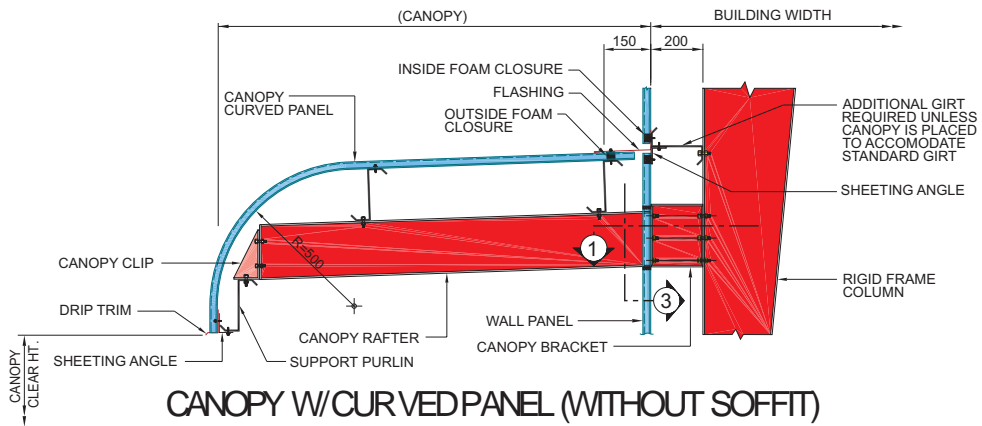
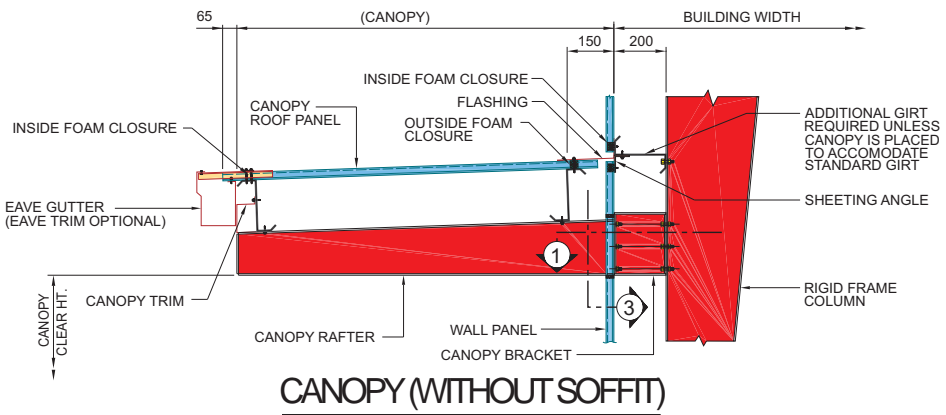
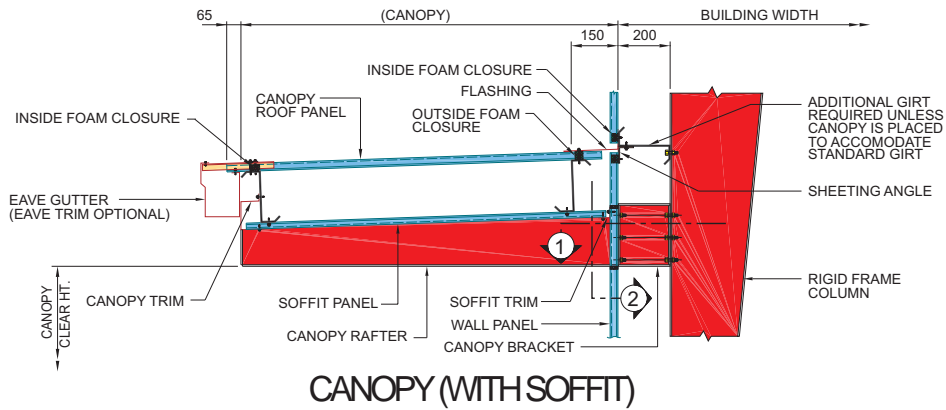

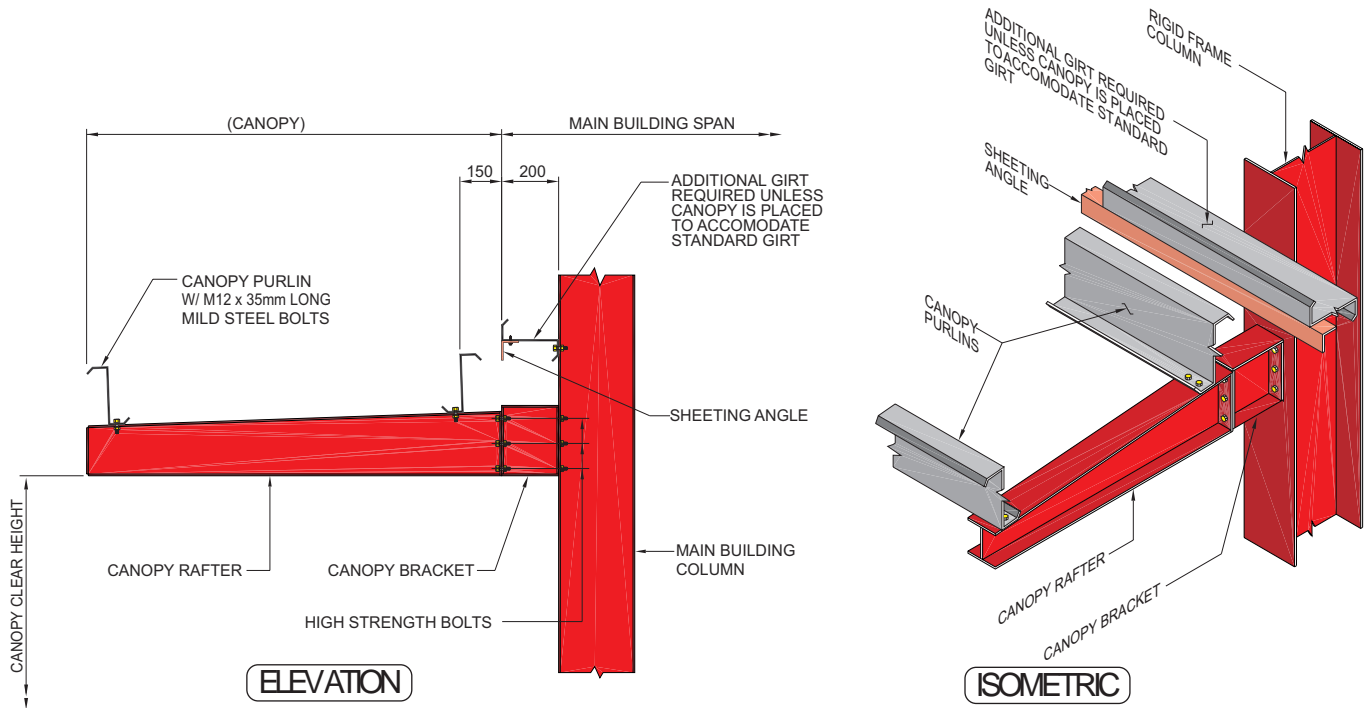

**DETAIL : CANOPY FRAMING DETAIL (WITH BY-PASS GIRTS)**

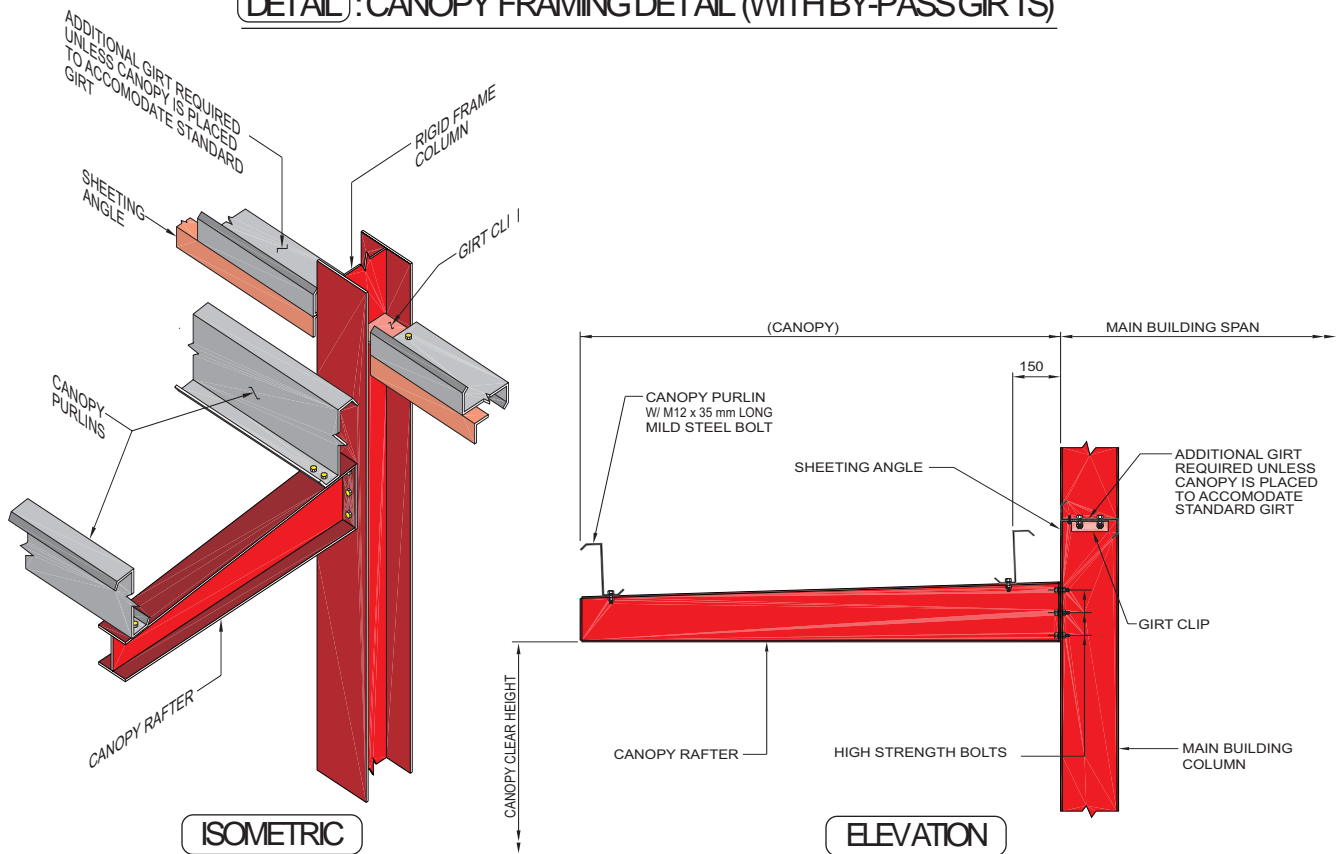

**DETAIL : CANOPY FRAMING DETAIL (WITH FLUSH GIRTS)**

When incorporated in a pre-engineered steel building, a fascia system enhances its appearance and transforms it from an ordinary looking structure into an attractive building.

Although the main purpose of a fascia is to conceal part or all of the gable roof, proper color coordination of the fascia sheeting, soffit, trims, and gutters and downspouts, generally enhances the aesthetics of a building and gives it a distinct appearance.

Zamil Steel offers five standard fascias:

- Vertical Fascia
- Bottom Curved Fascia
- Top and Bottom Curved Fascia
- Center Curved Fascia
- Parapet Fascia

The *vertical fascia* is the most common and economical type of fascia. It projects an image of strength by providing a bold bulky appearance and smooth linear edges.

This fascia may be provided with or without a soffit. A soffit contributes to a neat flush finish and is highly recommended.

Although the standard projection of this fascia is 600 mm, wider projections up to 1500 mm are common. The height of this type of fascia is variable and is determined mainly by the roof slope of the main building which is the rise of the roof from the eave line to the ridge line (peak).

The roof gutters are located in such a way as to prevent water from seeping through the fascia projection thus providing protection from the rain and shade from the sun.

The *curved fascias* (Bottom Curved Fascia, Top and Bottom Curved Fascia and Center Curved Fascia)

with their rounded sculptured corners and edges project a smooth and tranquil appearance.

The *parapet fascias* are extensions of the building walls in such a way as to conceal the building peak and are intended primarily to project a solid flat roof appearance.

No matter what you plan to use your building for, adding a fascia to it increases its value and enhances its aesthetic appearance and beauty.



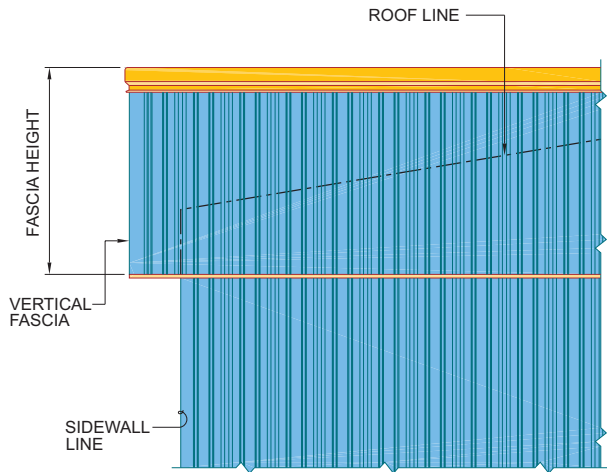

① VERTICAL FASCIA

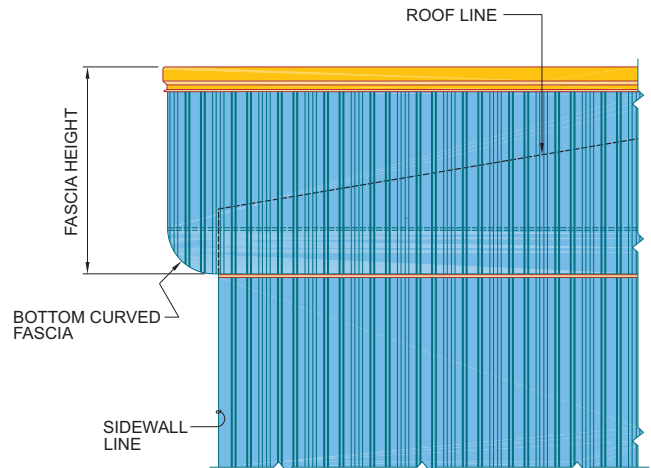

② BOTTOM CURVED FASCIA

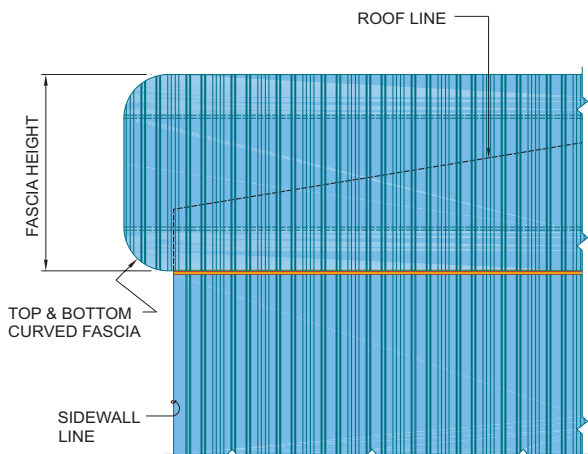

③ TOP AND BOTTOM CURVED FASCIA

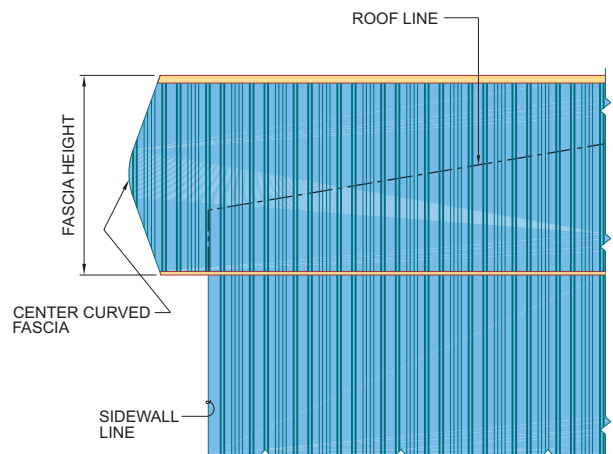

④ CENTER CURVED FASCIA

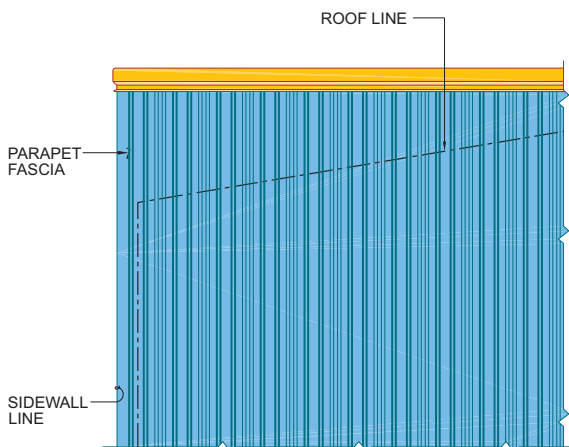

⑤ PARAPET (STEEL) FASCIA

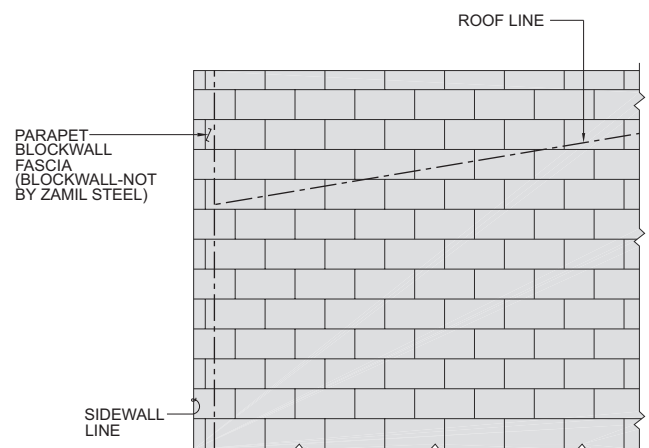

⑥ PARAPET (BLOCKWALL) FASCIA

(ELEVATION) : STANDARD FASCIAS VIEWED AT ENDWALL



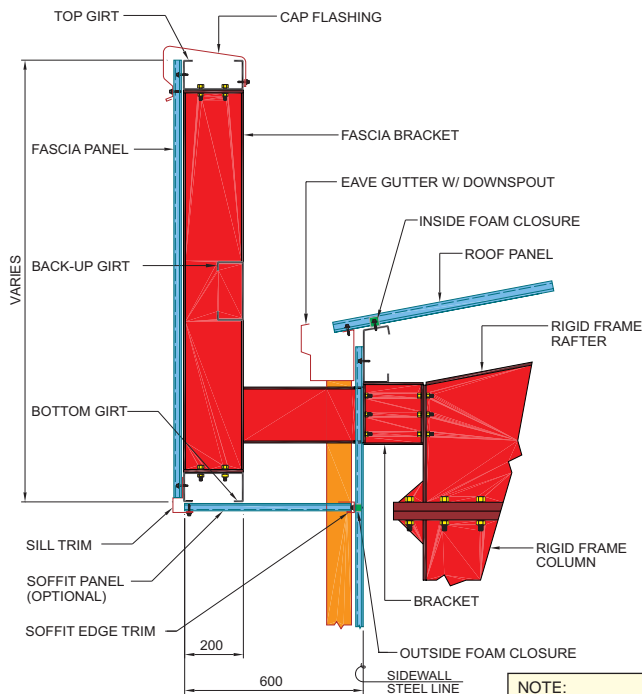

TYPICAL SIDEWALL SECTION

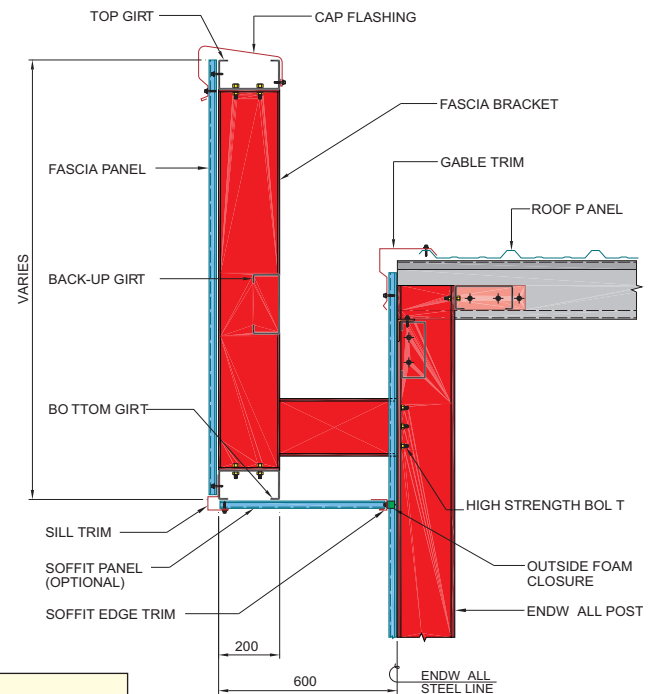

TYPICAL ENDWALL SECTION

NOTE:  
ALL ERECTION BOLTS USED FOR FIXING SHALL BE M12 x 35 mm LONG MILD STEEL BOLTS, UNLESS OTHERWISE SPECIFIED.

**SECTION :** VERTICAL FASCIA WITH EAVE GUTTER AND SOFFIT

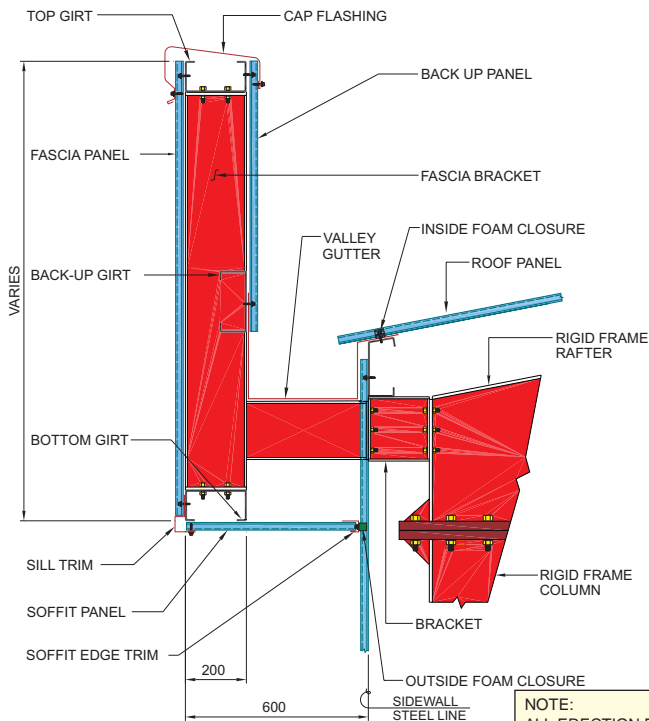

TYPICAL SIDEWALL SECTION

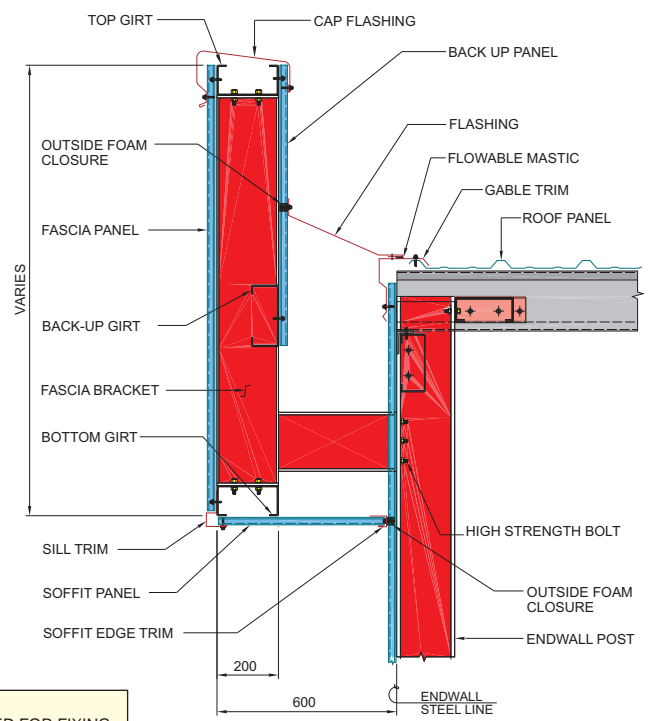

TYPICAL ENDWALL SECTION

NOTE:  
ALL ERECTION BOLTS USED FOR FIXING SHALL BE M12 x 35 mm LONG MILD STEEL BOLTS, UNLESS OTHERWISE SPECIFIED.

**SECTION :** VERTICAL FASCIA WITH VALLEY GUTTER, BACK-UP PANEL AND SOFFIT

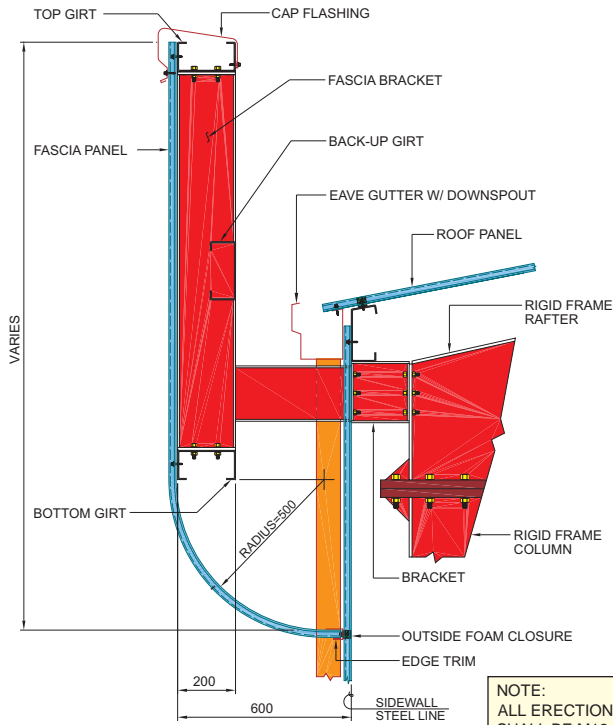

TYPICAL SIDEWALL SECTION

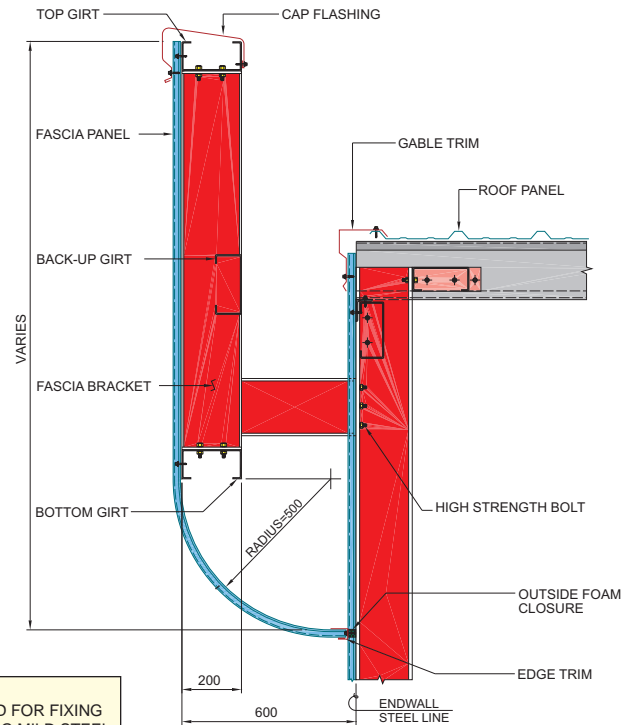

TYPICAL ENDWALL SECTION

NOTE:  
ALL ERECTION BOLTS USED FOR FIXING  
SHALL BE M12 x 35 mm LONG MILD STEEL  
BOLTS, UNLESS OTHERWISE SPECIFIED.

**SECTION : BOTTOM CURVED FASCIA WITH EAVE GUTTER**

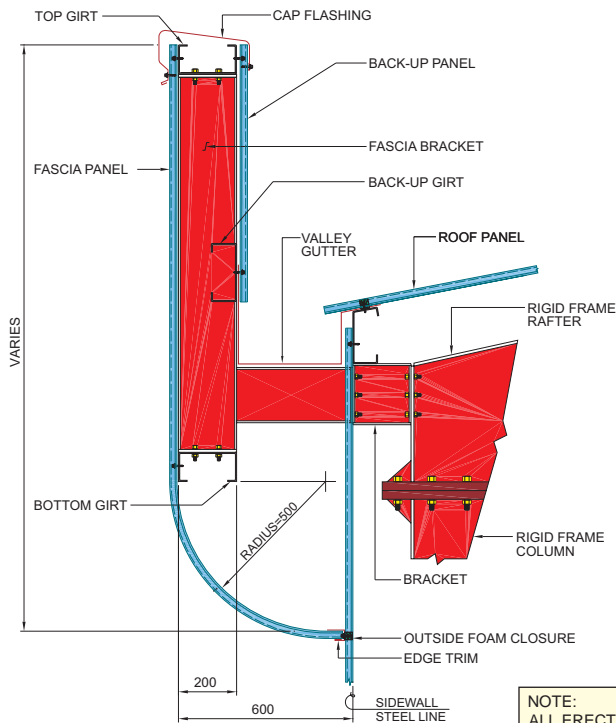

TYPICAL SIDEWALL SECTION

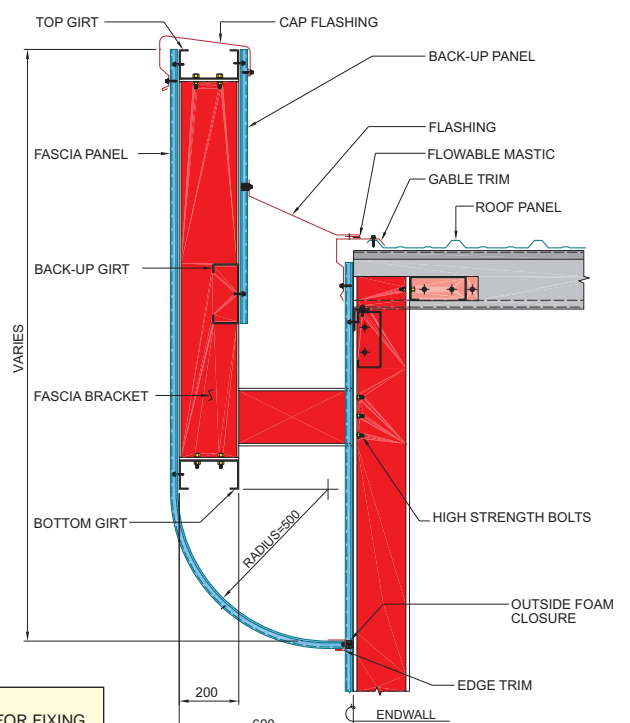

TYPICAL ENDWALL SECTION

NOTE:  
ALL ERECTION BOLTS USED FOR FIXING  
SHALL BE M12 x 35 mm LONG MILD STEEL  
BOLTS, UNLESS OTHERWISE SPECIFIED.

**SECTION : BOTTOM CURVED FASCIA WITH VALLEY GUTTER**

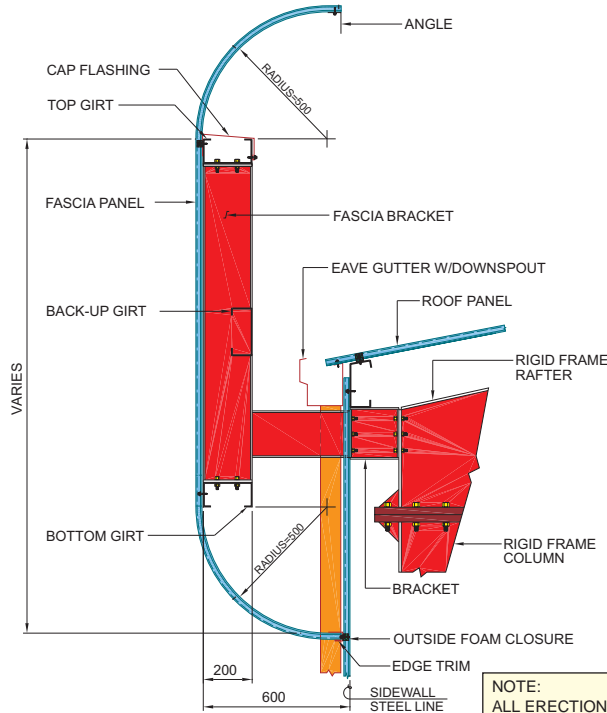

TYPICAL SIDEWALL SECTION

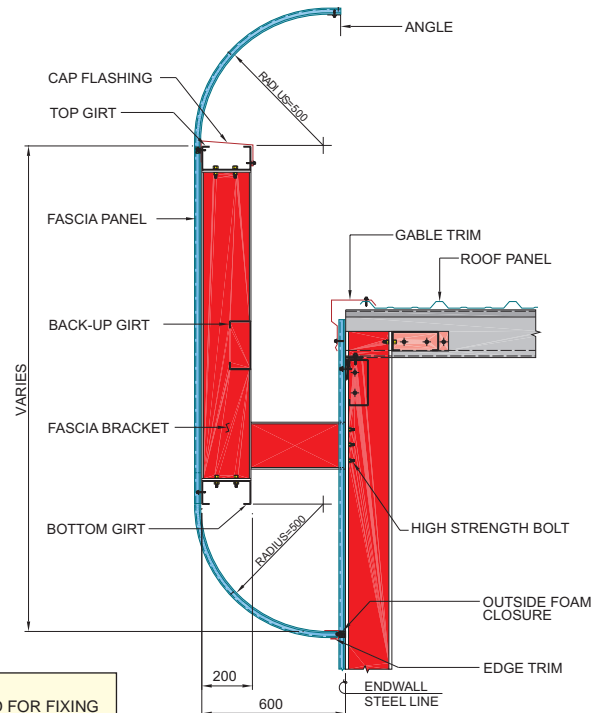

TYPICAL ENDWALL SECTION

NOTE:  
ALL ERECTION BOLTS USED FOR FIXING  
SHALL BE M12 x 35 mm LONG MILD STEEL  
BOLTS, UNLESS OTHERWISE SPECIFIED.

**SECTION :** TOP AND BOTTOM CURVED FASCIA WITH EAVE GUTTER

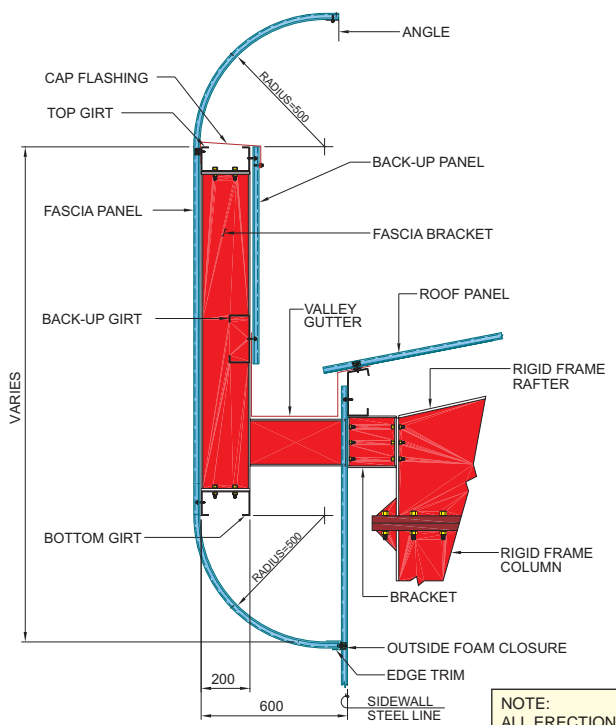

TYPICAL SIDEWALL SECTION

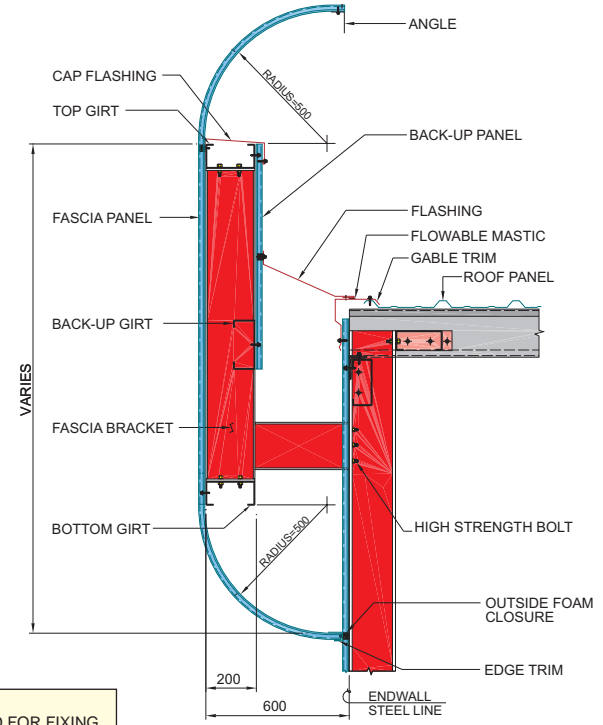

TYPICAL ENDWALL SECTION

NOTE:  
ALL ERECTION BOLTS USED FOR FIXING  
SHALL BE M12 x 35 mm LONG MILD STEEL  
BOLTS, UNLESS OTHERWISE SPECIFIED.

**SECTION :** TOP AND BOTTOM CURVED FASCIA WITH VALLEY GUTTER

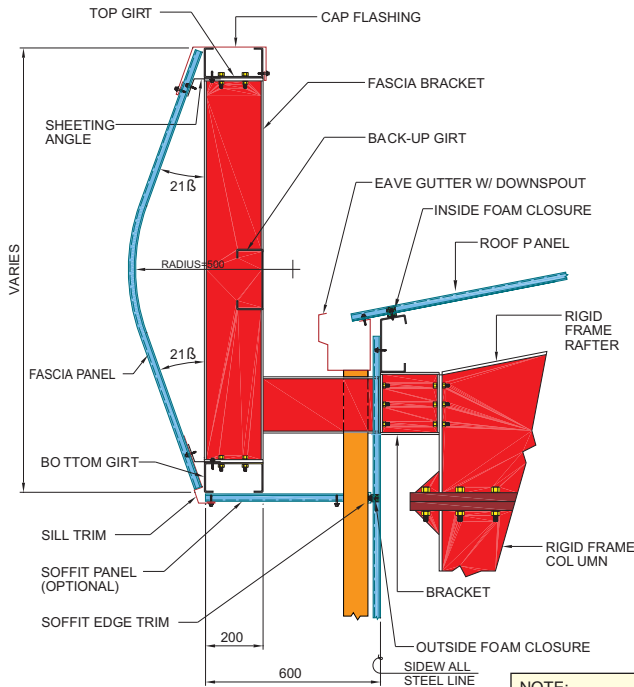

TYPICAL SIDEWALL SECTION

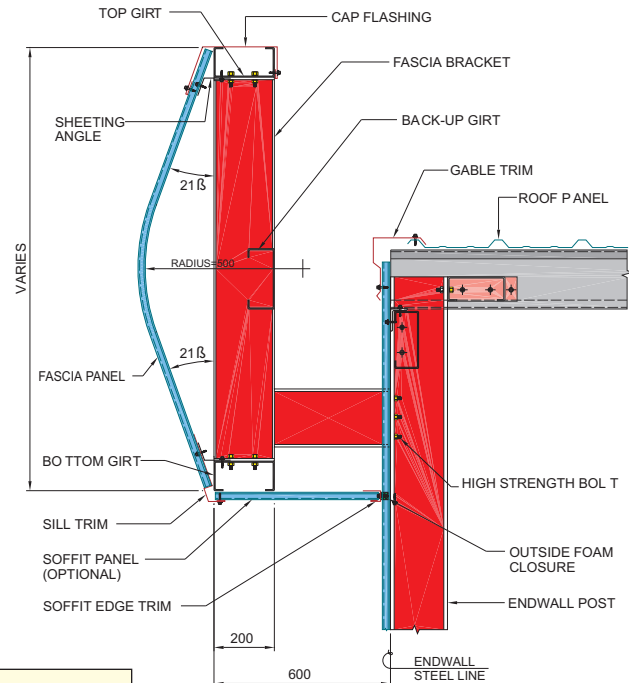

TYPICAL ENDWALL SECTION

NOTE:  
ALL ERECTION BOLTS USED FOR FIXING  
SHALL BE M12 x 35 mm LONG MILD STEEL  
BOLTS, UNLESS OTHERWISE SPECIFIED.

**SECTION :** CENTER CURVED FASCIA WITH EAVE GUTTER AND SOFFIT

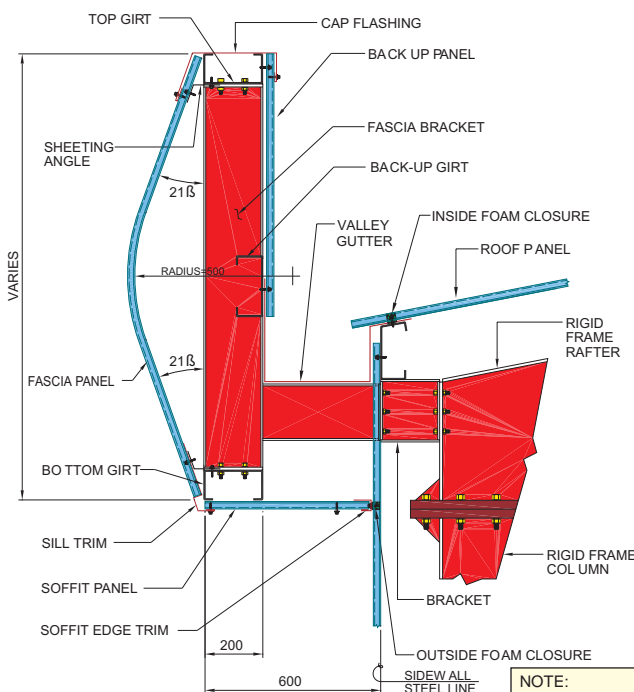

TYPICAL SIDEWALL SECTION

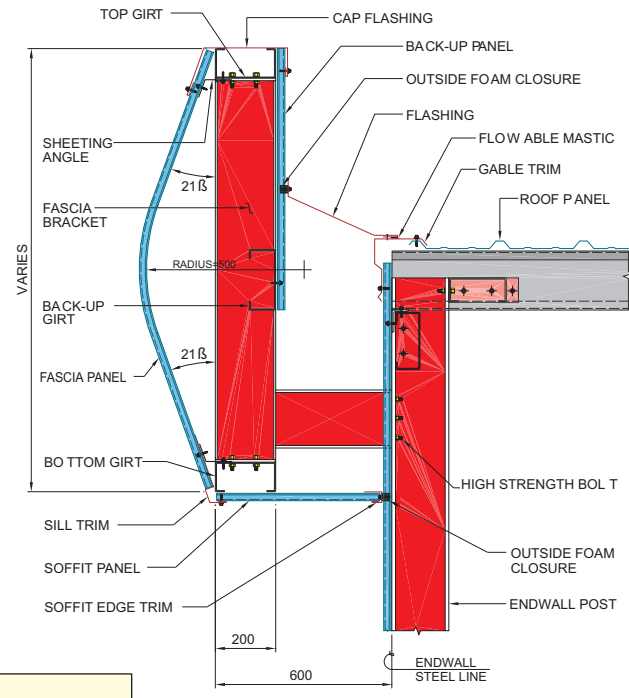

TYPICAL ENDWALL SECTION

NOTE:  
ALL ERECTION BOLTS USED FOR FIXING  
SHALL BE M12 x 35 mm LONG MILD STEEL  
BOLTS, UNLESS OTHERWISE SPECIFIED.

**SECTION :** CENTER CURVED FASCIA WITH VALLEY GUTTER AND SOFFIT

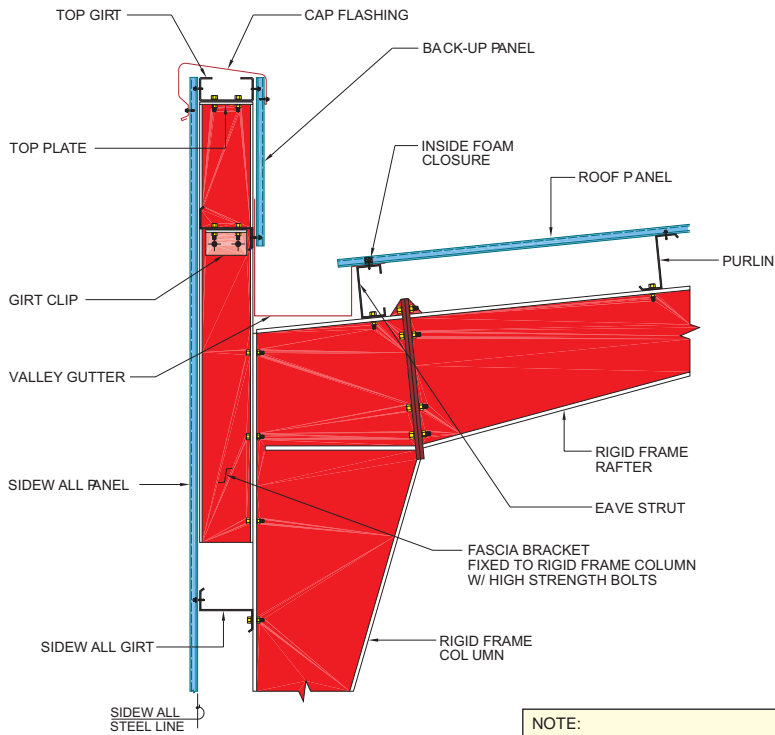

TYPICAL SIDEWALL SECTION

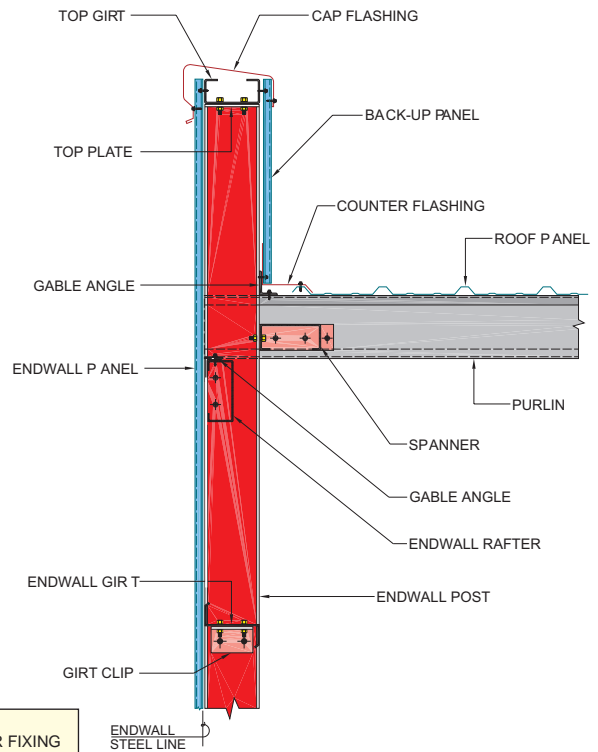

TYPICAL ENDWALL SECTION

NOTE:  
ALL ERECTION BOLTS USED FOR FIXING SHALL BE M12 x 35 mm LONG MILD STEEL BOLTS, UNLESS OTHERWISE SPECIFIED.

**SECTION : PARAPET (STEEL) FASCIA**

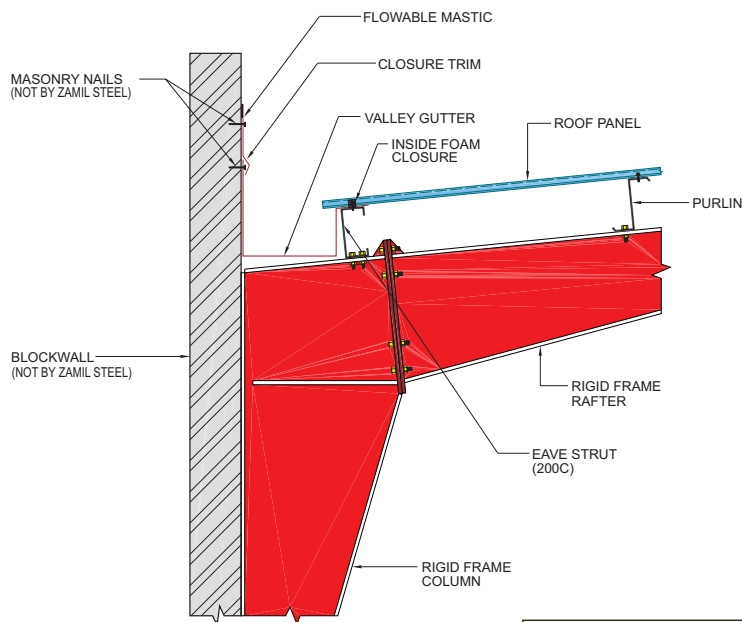

TYPICAL SIDEWALL SECTION

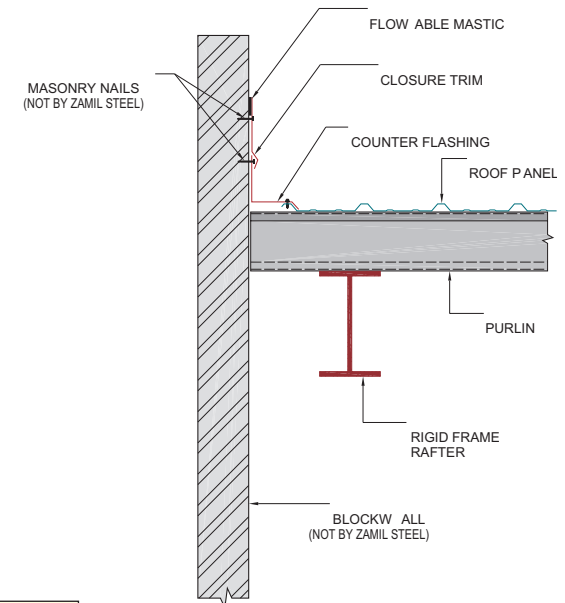

TYPICAL ENDWALL SECTION

NOTE:  
ALL ERECTION BOLTS USED FOR FIXING SHALL BE M12 x 35 mm LONG MILD STEEL BOLTS, UNLESS OTHERWISE SPECIFIED.

**SECTION : PARAPET (BLOCKWALL) FASCIA**

A **partition** in a pre-engineered steel building is an interior non-load bearing wall designed to serve as a division within the building. It can be placed anywhere inside the building and consists of pinned or fixed base columns spaced 6 m to 9 m apart and connected by flush-framed wall girts. Partitions are sometimes connected at the top to rigid frame rafters or to the purlins.

A steel partition consists of built-up or cold-formed structural columns, horizontal wall girts and full or partial sheeting on one side or on both sides of the partition framing. Partitions sustain their own weight (they are not designed to support ceiling or roof systems) and are designed to withstand a maximum lateral (wind) load of 0.25 kN/m<sup>2</sup>.

Standard accessories such as personnel doors, windows, louvers, framed openings, sliding doors, roll-up doors, etc. can be easily incorporated in partitions.

Partitions may be *transverse* or *longitudinal*.

Transverse partitions run parallel to the main rigid frames (across the width of the building). They can be placed at an interior rigid frame or between any two rigid frames.

Longitudinal partitions run parallel to the length of the building.

The standard Zamil Steel sheeting panel used in interior partitions is 0.5 mm thick (nominal) Profile "R" panel (Zincalume finished) pre-painted in Frost White color.

In some applications it may be desirable to sheet partitions with Zamil Steel's Profile "B", Profile "A", Profiles "D" / "E" or Tempcon Low Rib panel (TCLR) which are all available in 0.5 mm thick (nominal) Frost White painted Zincalume.



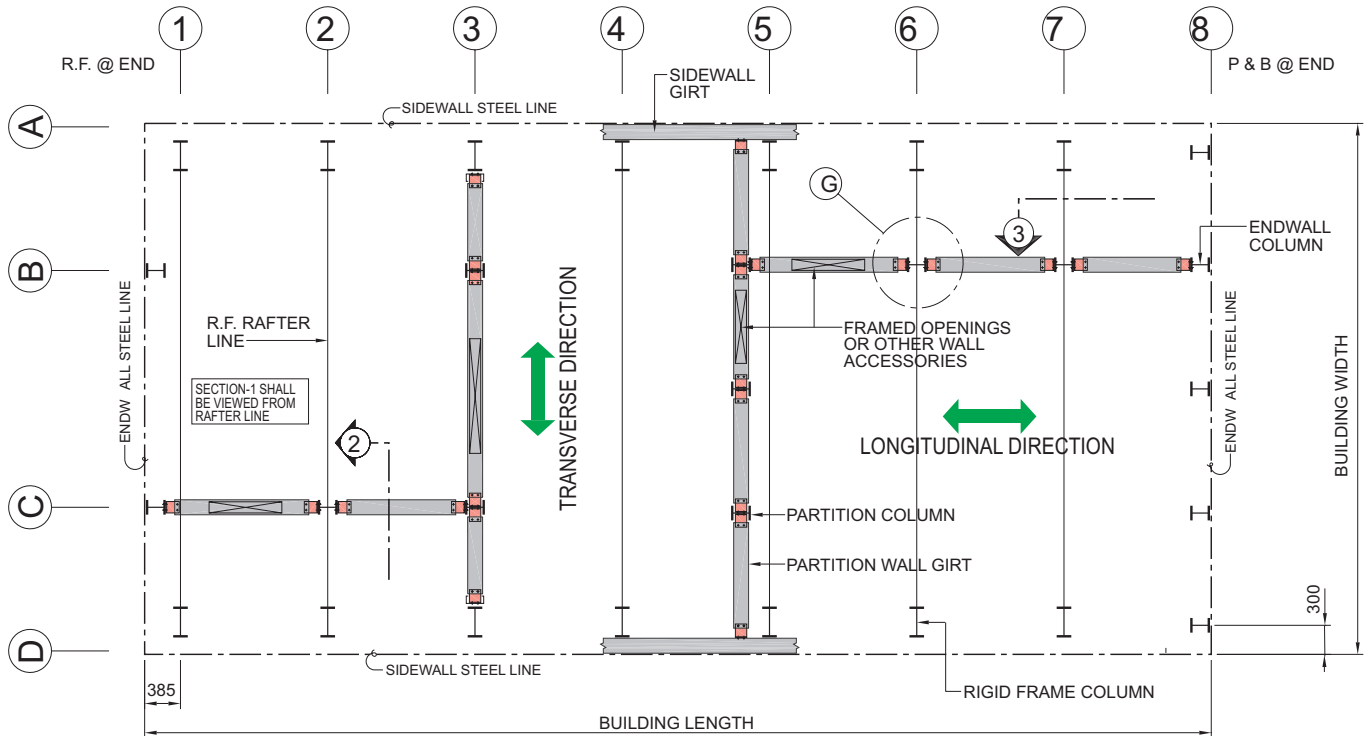

**PLAN** : TRANSVERSE AND LONGITUDINAL PARTITION FRAMINGS

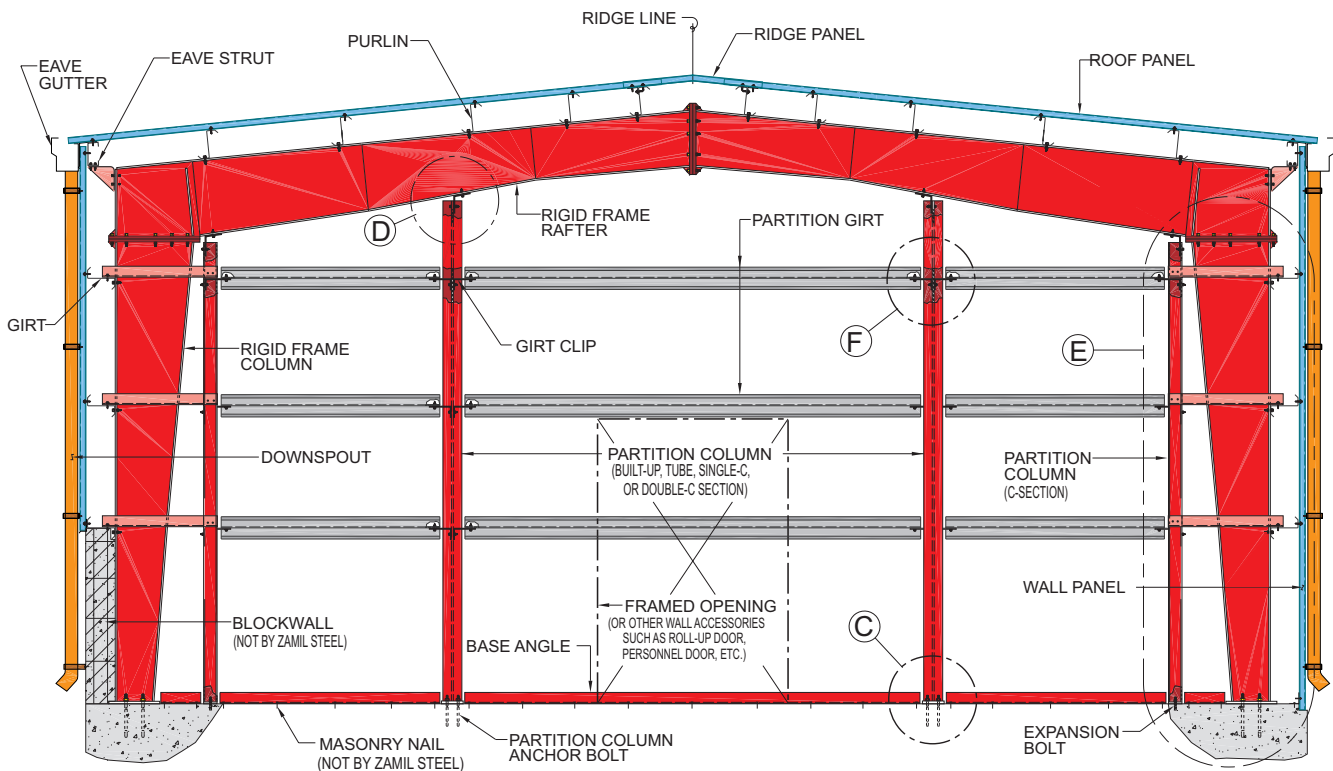

**ELEVATION** : TRANSVERSE PARTITION FRAMING CONNECTED TO RIGID FRAME

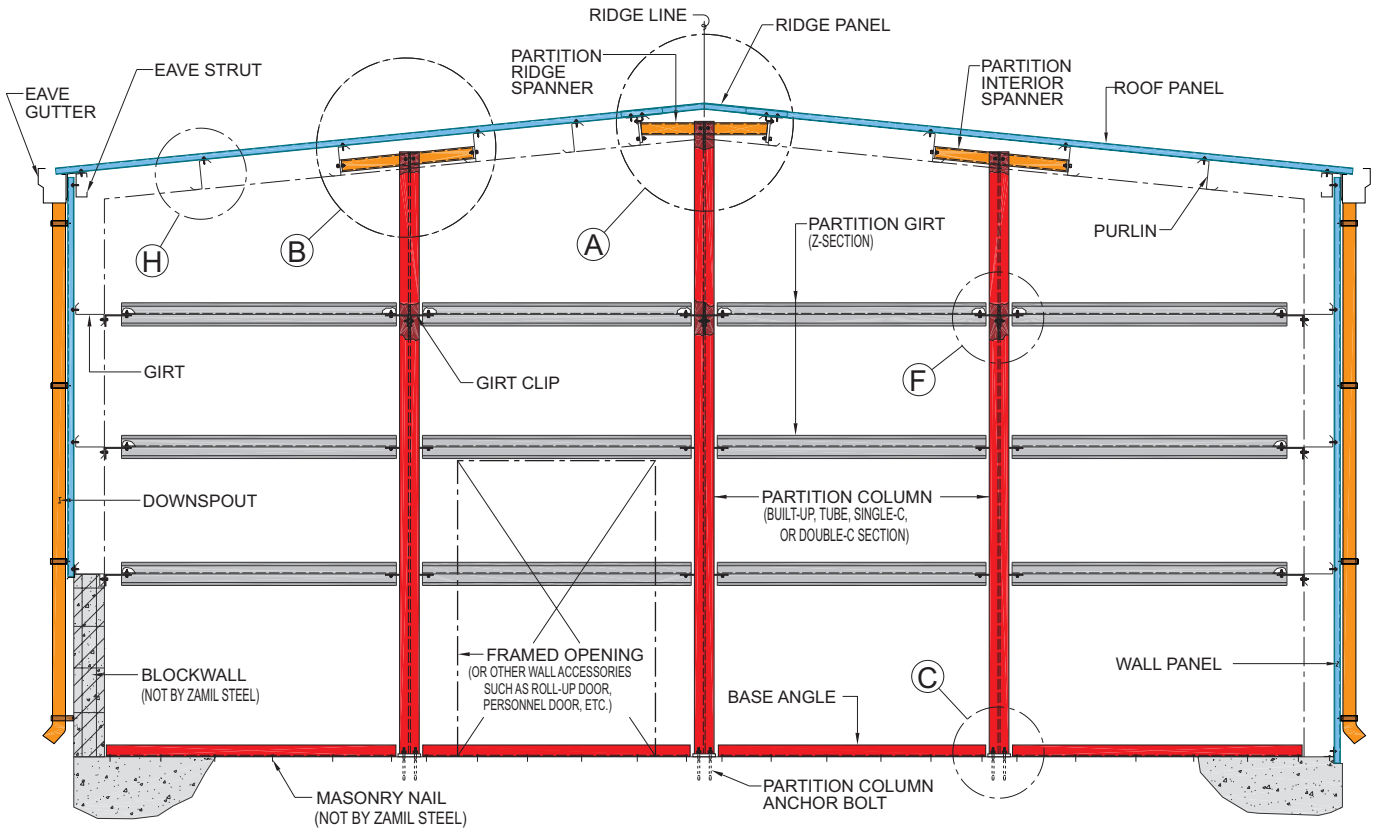

**(ELEVATION) : TRANSVERSE PARTITION FRAMING CONNECTED TO PURLIN**

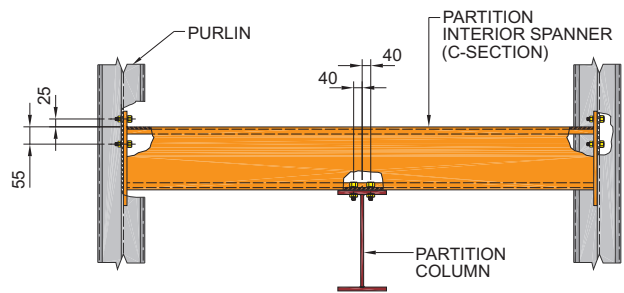
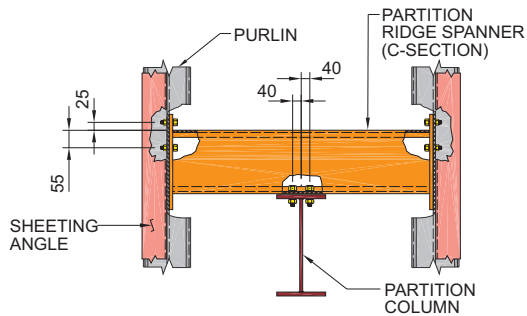
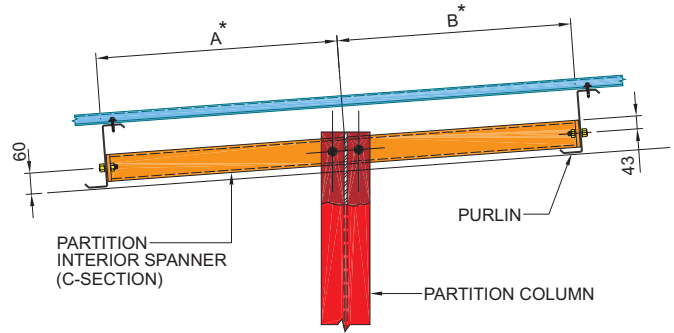
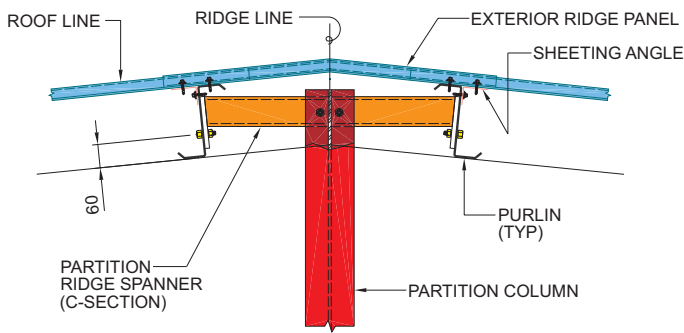

NOTE:  
ALL BOLTS USED ARE M12 x 35 mm LONG HIGH STRENGTH BOLTS.

NOTE:  
1. ALL BOLTS USED ARE M12 x 35 mm LONG HIGH STRENGTH BOLTS.  
\*2. DIMENSIONS 'A' OR 'B' SHOULD BE NOT LESS THAN 200 mm FOR SPANNER CONNECTION.

**(DETAIL-A) : PARTITION COLUMN CONNECTION AT RIDGE**

**(DETAIL-B) : PARTITION COLUMN CONNECTION AT PURLIN**



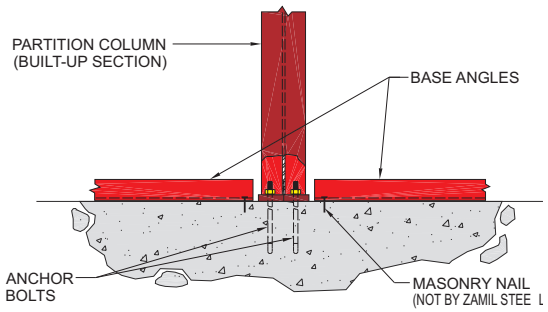
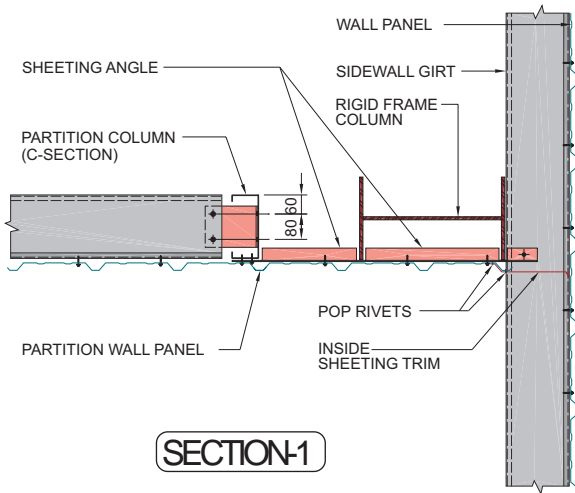

NOTE:  
SQUARE TUBE SECTION, DOUBLE-C OR SINGLE-C (COLD-FORMED) SECTIONS MAY ALSO BE USED INSTEAD OF BUILT-UP SECTIONS AS PARTITION COLUMNS.

**DETAIL-C : INTERIOR PARTITION COLUMN**

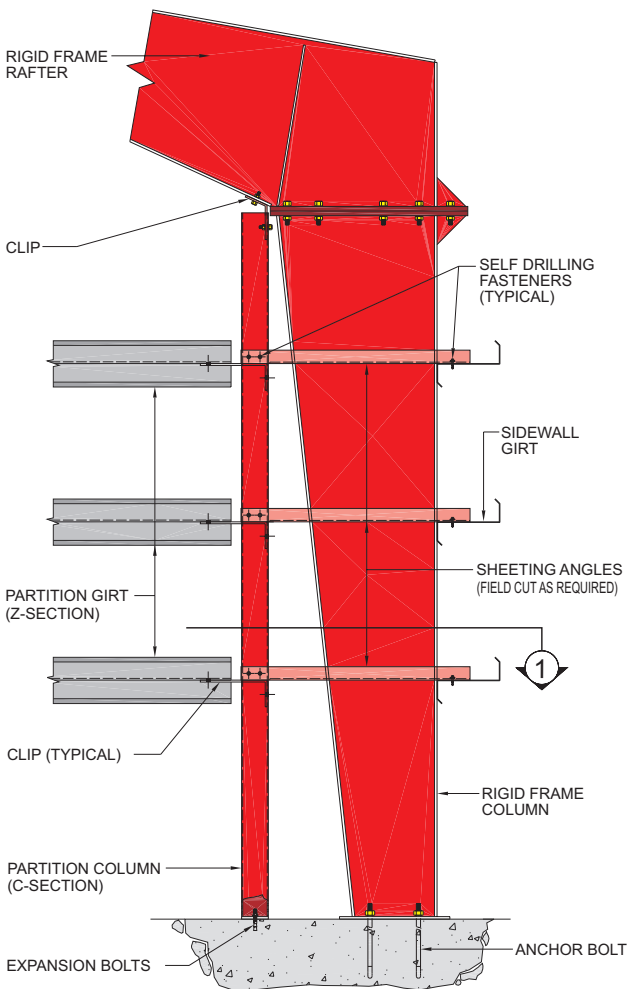

**DETAIL-E : PARTITION WALL CONNECTION TO R.F. COLUMN**

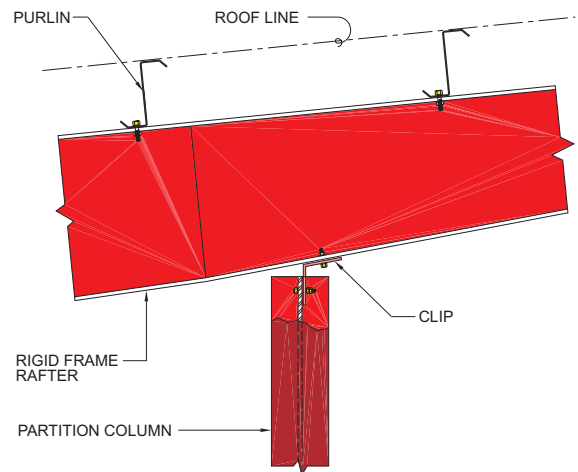

**DETAIL-D : PARTITION COLUMN CONNECTION AT RAFTER**

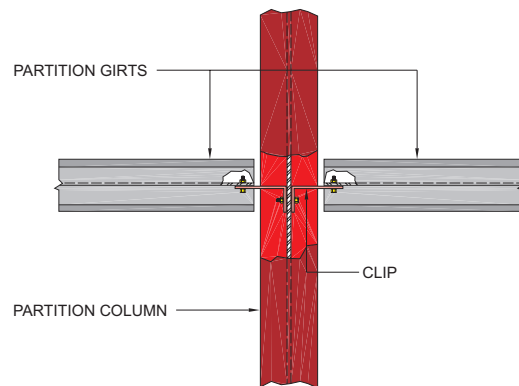

**DETAIL-F : PARTITION GIRTS CONNECTION TO COLUMN**

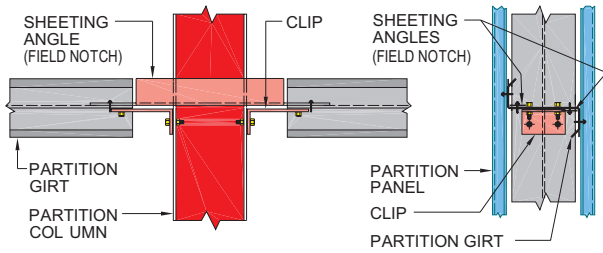

FRAMING ELEVATION

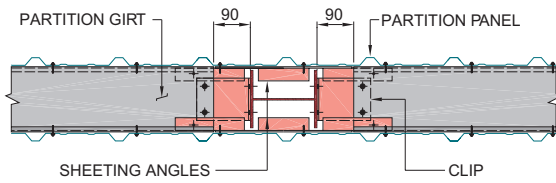

PLAN

DETAIL-G : PARTITION COLUMN CONNECTION AT GIRT

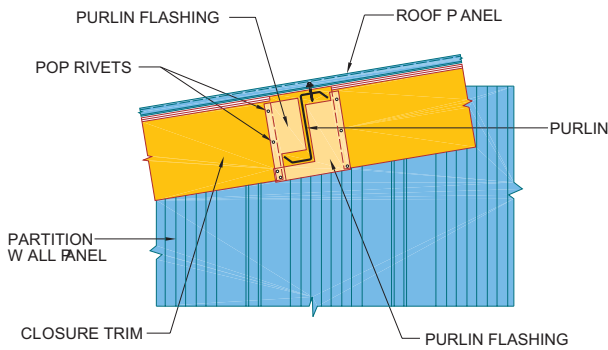

DETAIL-H : PURLIN FLASHING AT PARTITION WALL

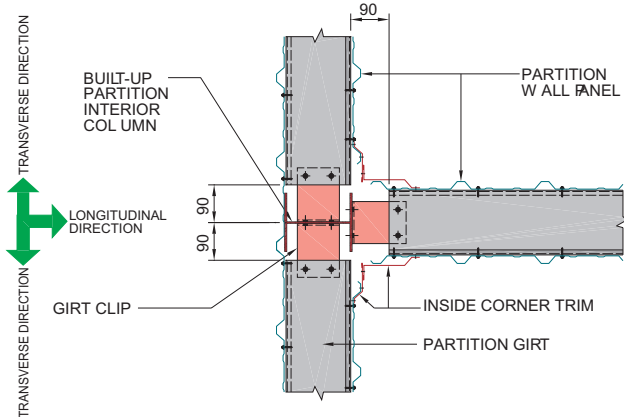

CONNECTION AT BUILT-UP PARTITION INTERIOR COLUMN

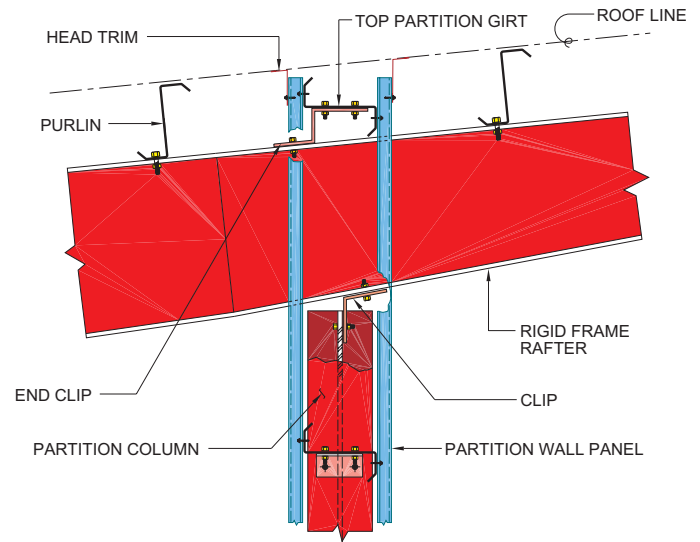

SECTION-2 : PARTITION GIRT CONNECTION AT R.F. RAFTER

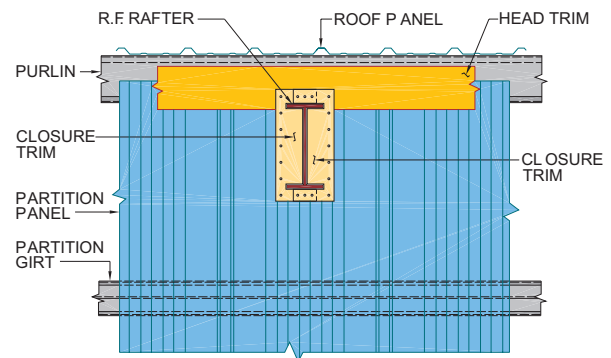

SECTION-3 : CLOSURE TRIM AT PARTITION WALL & RAFTER

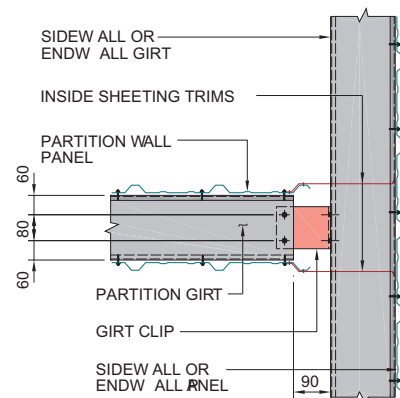

PARTITION WALL GIRT ALIGNED TO SIDEWALL OR ENDWALL GIRT CONNECTION

Increasingly, the benefits of **crane systems** in factories and warehouses are being appreciated by more and more of our endusers.

A crane system greatly improves material handling productivity within a building, promotes safety and allows more efficient utilization of space by reducing or eliminating traffic due to forklifts and side loaders.

The incremental cost of designing a building to accept a future crane system can be easily justified, when considering the long-term merits of a crane system, especially when the additional cost is spread over the lifetime usage of the building.

Adding a crane system to a finished pre-engineered steel building, that has not been initially designed to support it, is both cumbersome and uneconomical. For this reason, building planners must consider not only the initial use of the building, but also its potential usage throughout the lifetime of the building.

The costs involved in adding a crane system to a pre-engineered steel building consist of:

1. Strengthening the building's main frames to support the crane loads.
2. Supplying the crane brackets and crane runway beams that support the crane system.
3. Supplying and installing crane rails.
4. Supplying, installing and commissioning the crane system.

Zamil Steel's supply is normally limited to items 1 and 2. Supply, installation and commissioning of the crane system and crane rails are handled by specialist "crane systems" companies.

The most common types of crane systems in pre-engineered steel buildings are:

- Top Running Cranes
- Underhung Cranes
- Monorail Cranes
- JIB Cranes
- Gantry Cranes
- Semi-Gantry Cranes

When designing a pre-engineered steel building frame for crane loads, it is essential to furnish Zamil Steel with the crane manufacturer's name, the crane system model no. and the crane system data sheet. This information is required to enable Zamil Steel to make a safe and economical design for the building's frames and the crane runway beams.



If the crane system is not specified by the customer, Zamil Steel will assume the crane specifications of the following manufacturers depending on the job location.

For further details please contact your nearest Zamil Steel Area Office or contact the above crane manufacturers directly.

No.	Crane Manufacturer	Job Location
1.	<b>MORRIS CRANES</b> P.O. Box 9, Al Khobar 31952 Saudi Arabia Phone (966 3) 8593232 Fax (966 3) 8591966	Saudi & Gulf regions
2.	<b>CRANEMANN, INC.</b> 13938 Chrisman Road Houston, Texas 77039, U.S.A Phone (1 281) 4422424 Fax (1 281) 4427558	North America, South America & Africa regions
3.	<b>KONE CRANES</b> Hoists and Standard Components Ruununmyllyntie 13 13210 Hameenlinna, Finland Phone (358 17) 61481 Fax (358 17) 6148229	Europe, Central Asia & CIS Countries
4.	All other regions subject to the preference of the customer.	

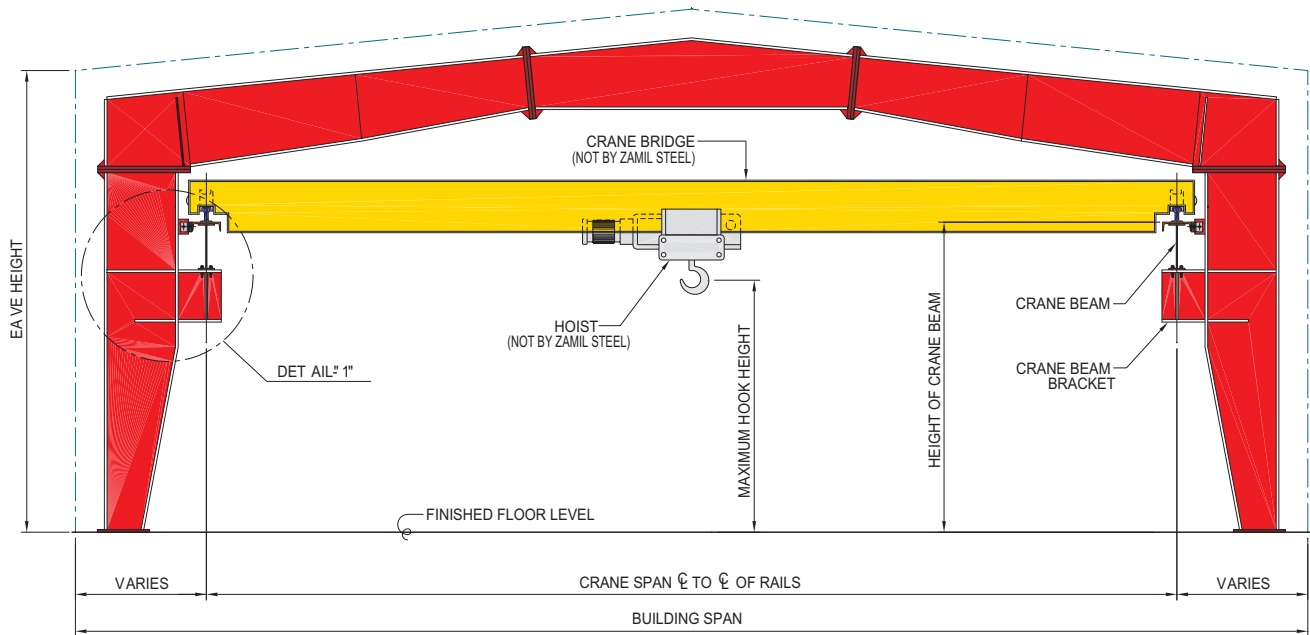

**ELEVATION** : TOP RUNNING CRANE IN A CLEAR SPAN BUILDING

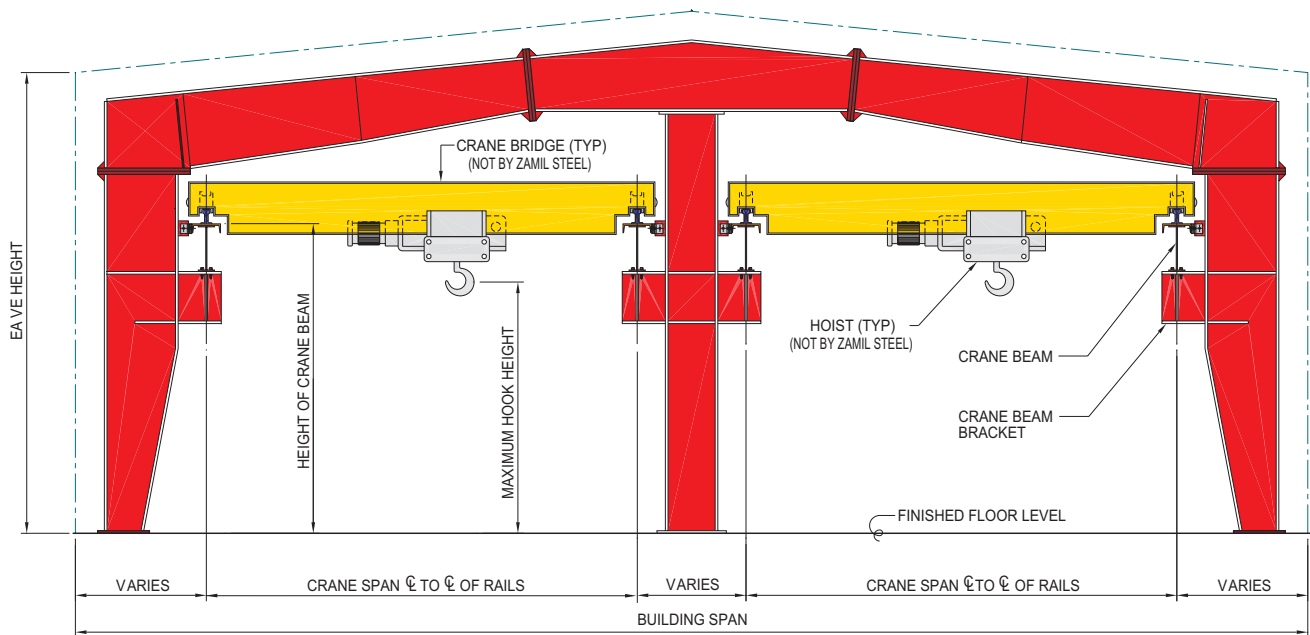

**ELEVATION** : TOP RUNNING CRANE IN A MULTI-SPAN BUILDING

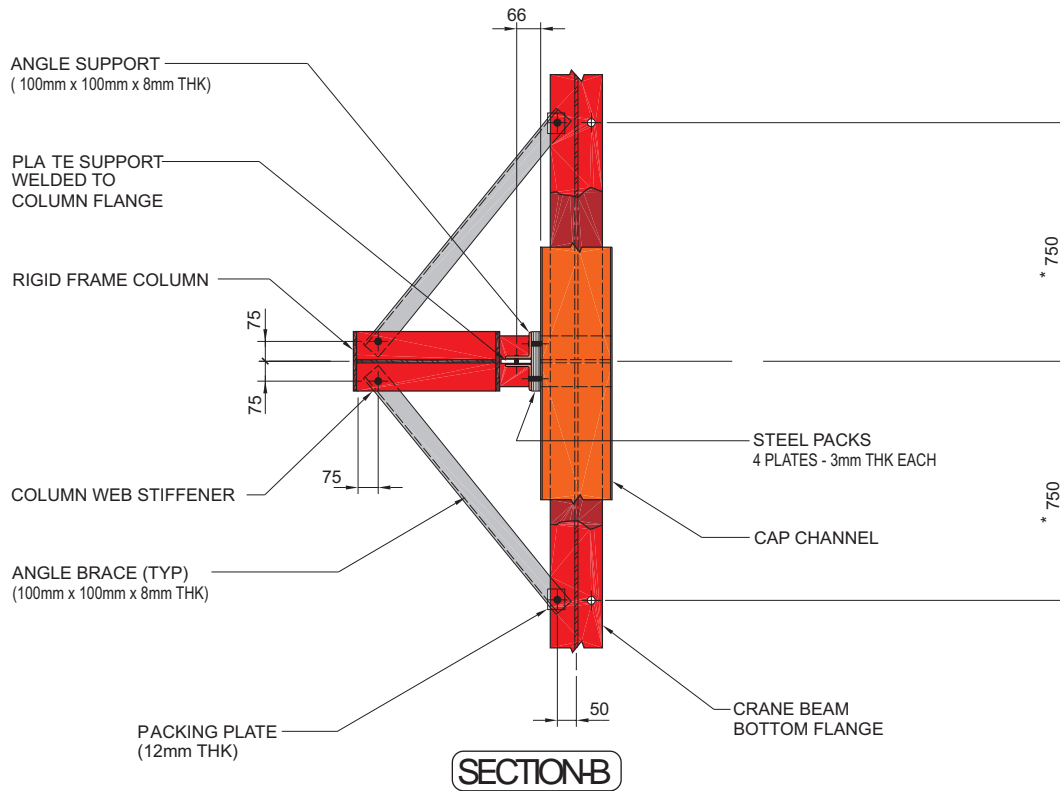

\*730 FOR RIGID FRAME COLUMNS WITH DEPTH UP TO 800 mm  
\*1380 FOR RIGID FRAME COLUMNS WITH DEPTH MORE THAN 800 mm

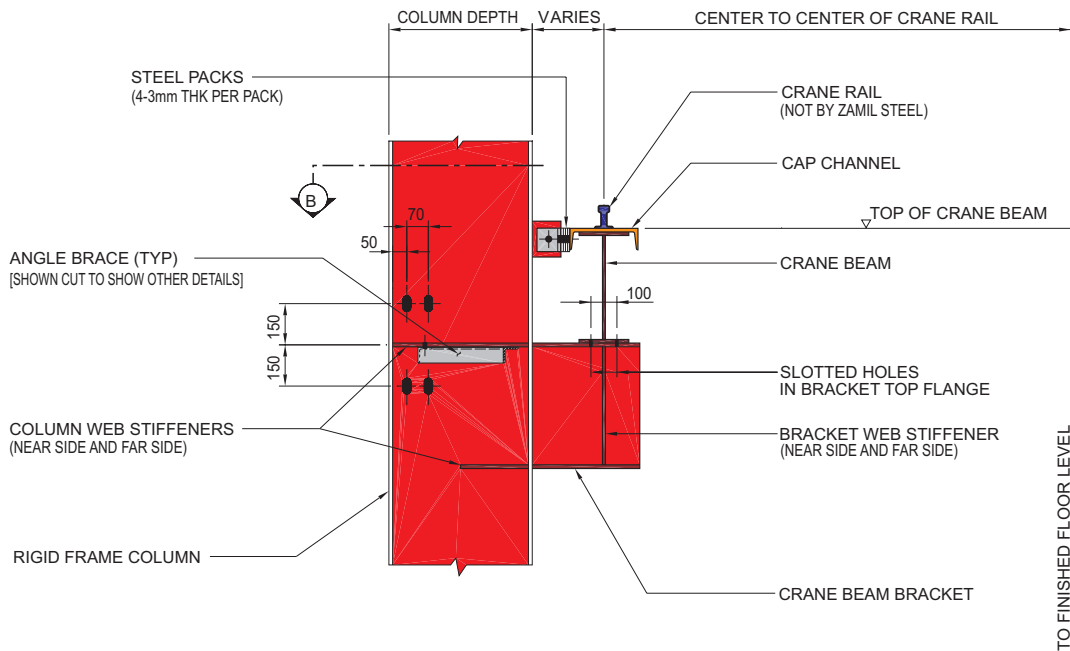

**DETAIL-1** : CRANE BEAM AND BRACKET ASSEMBLY

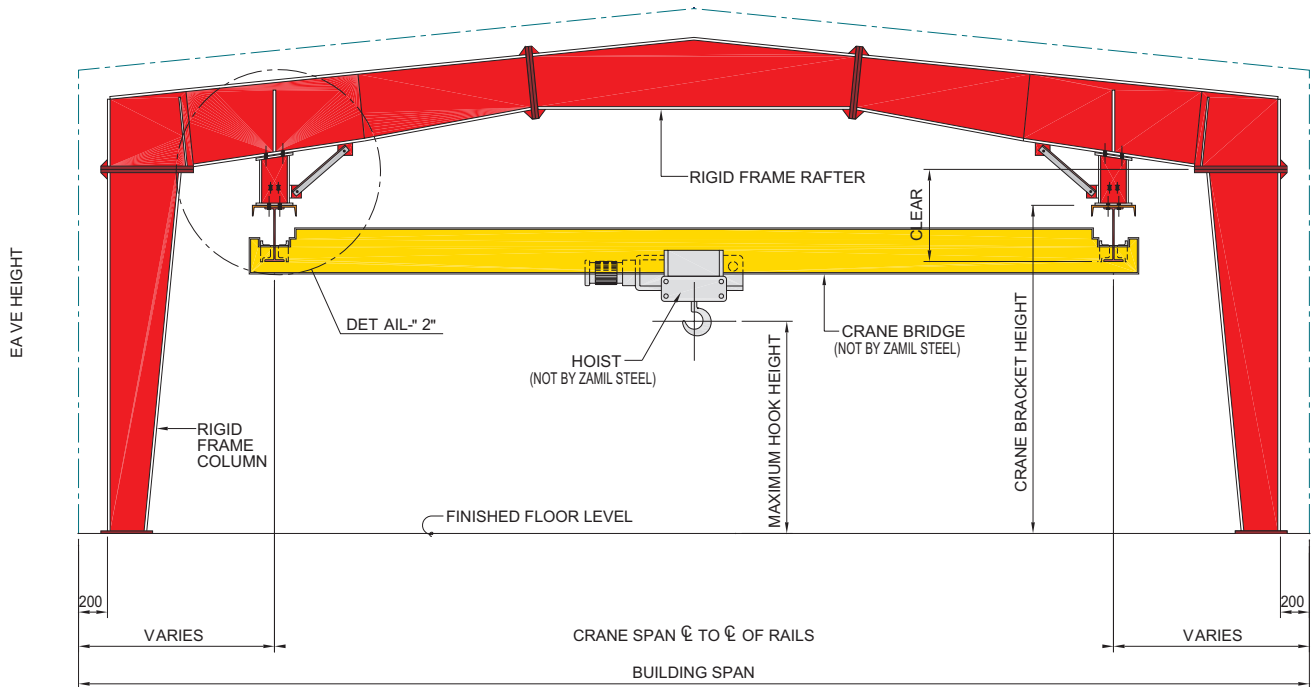

**ELEVATION**: UNDERHUNG CRANE

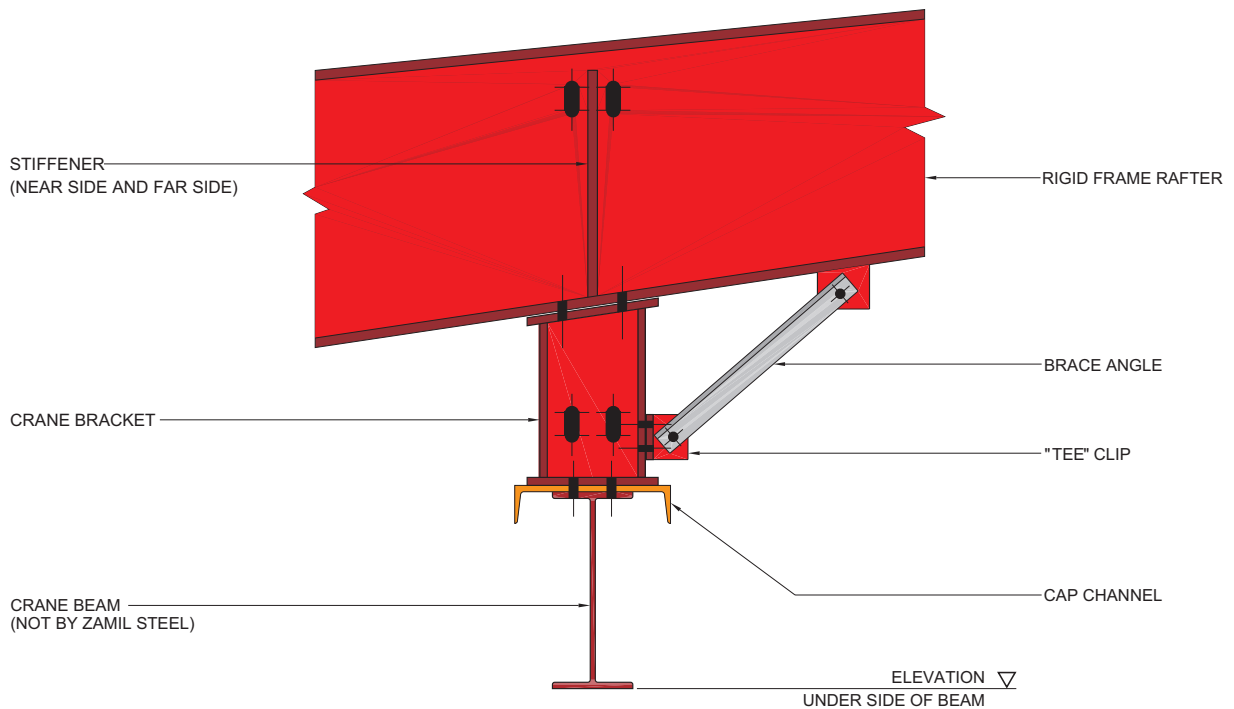

**DETAIL-2**

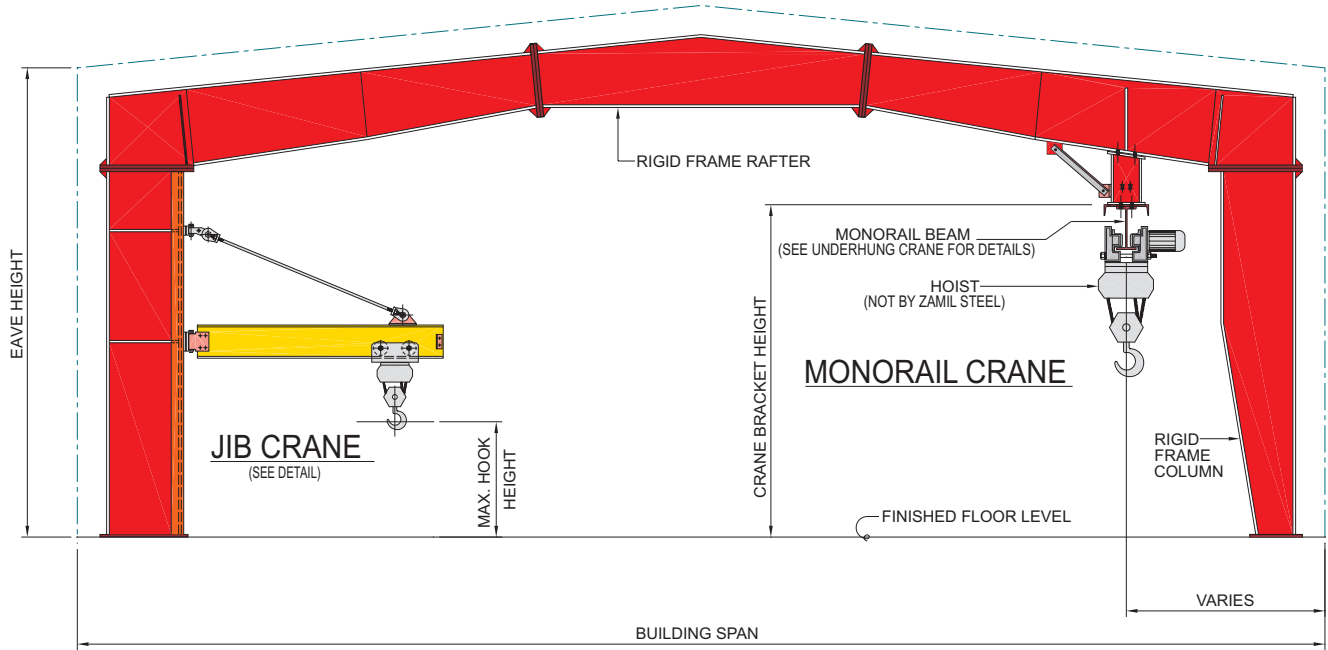

**ELEVATION** : JIB CRANE AND MONORAIL CRANE

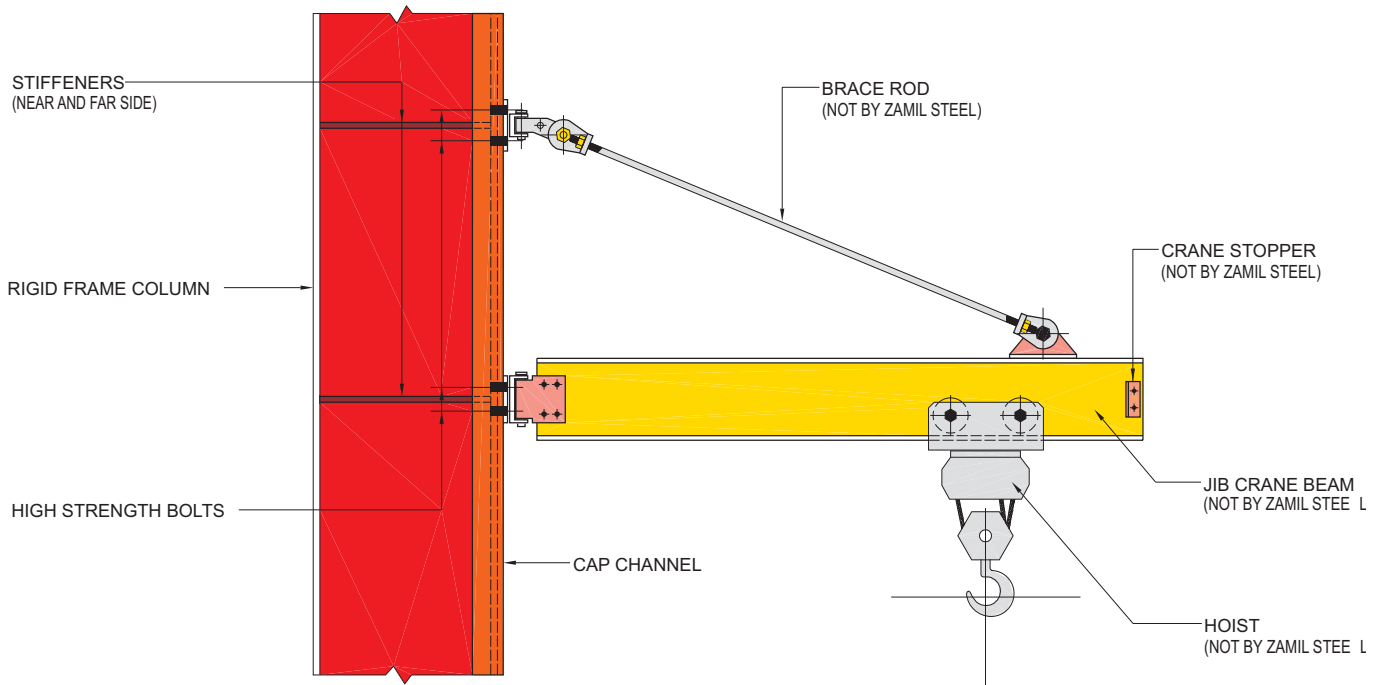

**ELEVATION** : JIB CRANE DETAIL



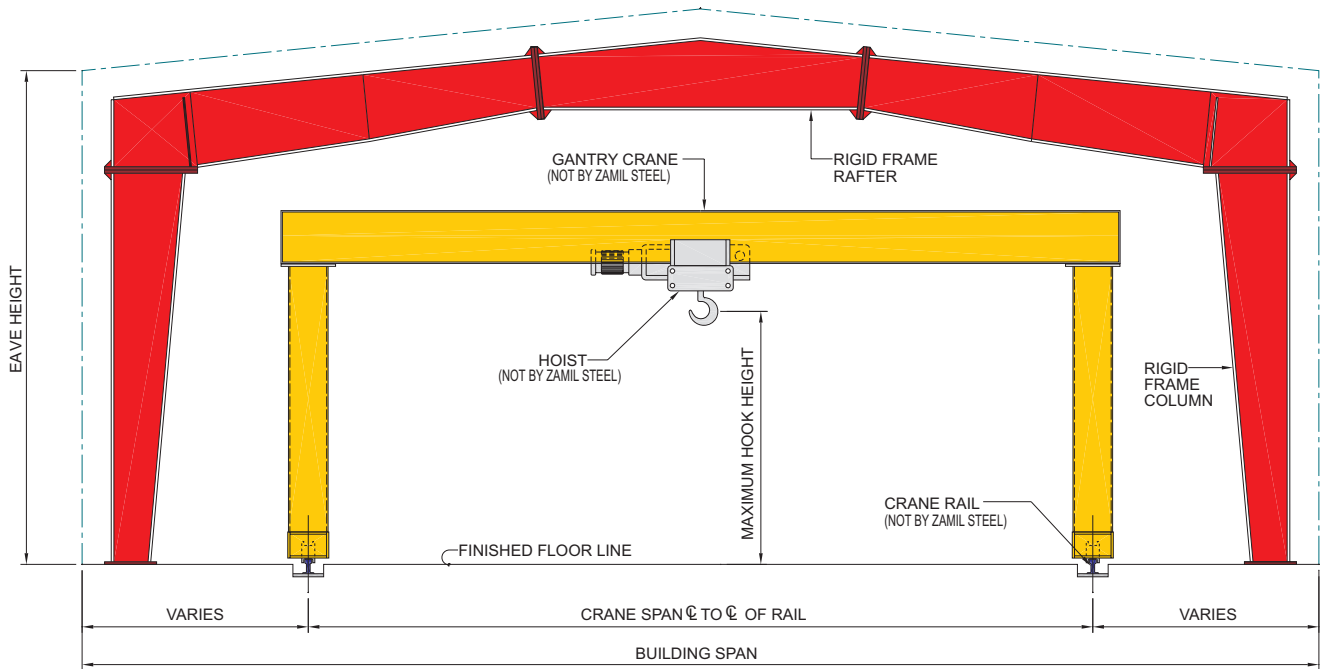

**ELEVATION** : GANTRY CRANE

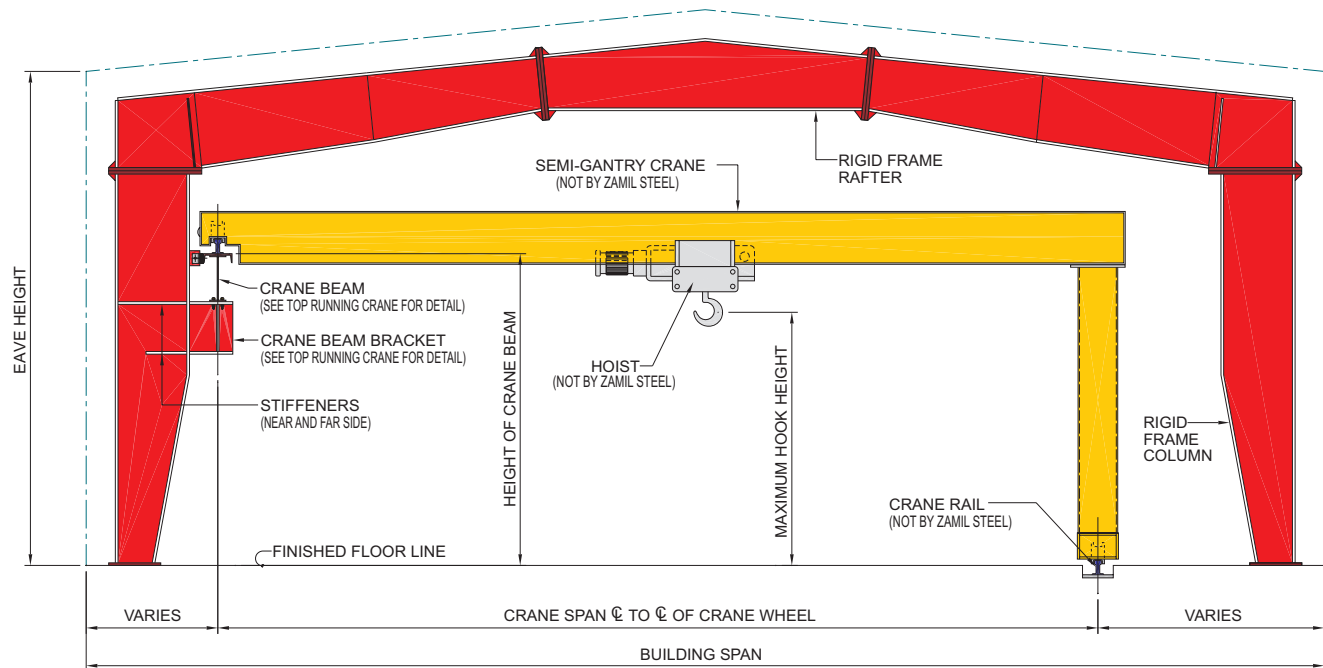

**ELEVATION** : SEMI-GANTRY CRANE

Zamil Steel's **roof monitor** combines economy, good appearance and easy erection. The size of the monitor can be adjusted to suit exact ventilation and lighting requirements. The overhang part is detailed to give a 45° protection from the rain. A light wire mesh is installed at 45° to prevent intrusion of birds. A curved eave panel may be incorporated at the eave of the monitor. It is very conducive to tropical areas where rainfall is normally heavy. Generally, roof monitors are made of lightweight, yet strong, cold-formed sections. Built-up sections and hot rolled sections are used for the framing members when the roof monitor is large and design warrants their use.

When using the roof monitor as a gravity ventilator, an efficiency factor of 0.60 is recommended for calculation of effective area using the following equation:

$$\text{Total ventilator area} = \frac{VR_{\text{req'd}}}{[0.03 \times \text{Stack height} \times T]^{1/2}} \quad \text{where,}$$

$VR_{\text{req'd}}$  = Ventilation rate required  
(see **subsection 13.7.1**)

T = Temperature difference (use °C difference per meter of stack height)

$$\text{Monitor area} = \frac{\text{Ventilation Area}}{0.60}$$

For more details on ventilation, please refer to **section 13.7** of this manual.

For natural lighting, an efficiency factor of 0.60 should be used to calculate the opening area of the roof monitor. This roof monitor can be used in natural lighting calculations for buildings where height/width ratio of the building does not exceed 0.25.



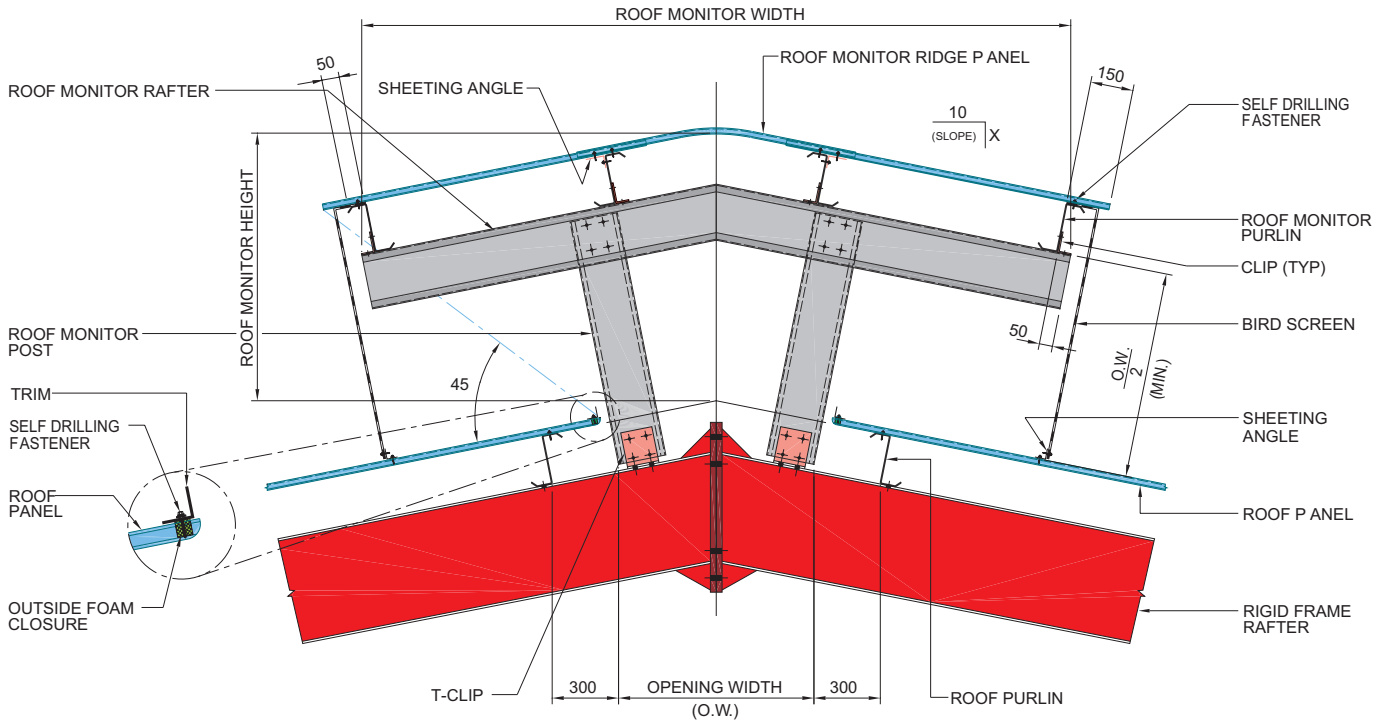

**SECTION : STANDARD ROOF MONITOR**

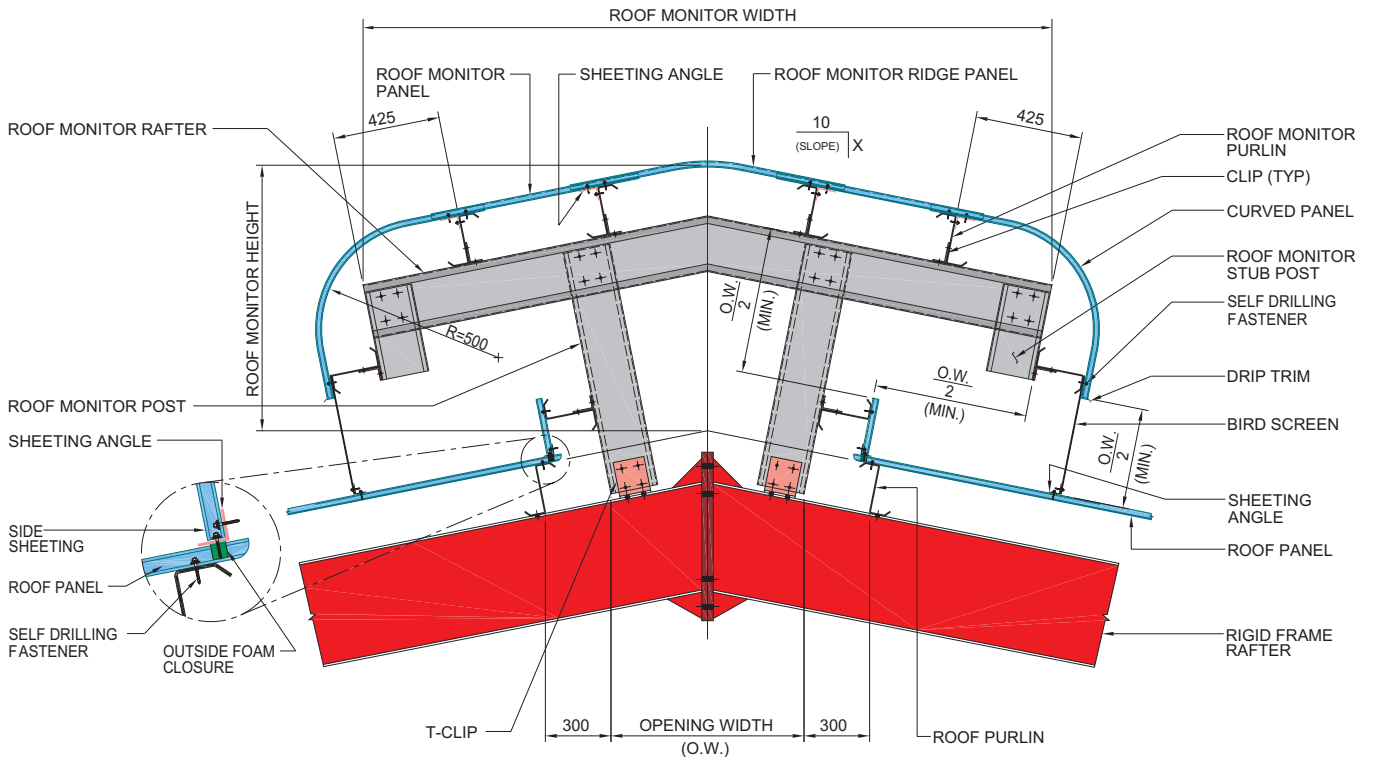

**SECTION : ROOF MONITOR WITH CURVED PANEL**



# FLOOR SYSTEMS

# C H A P T E R

12

# Floor Systems

121	General .....	279
122	Mezzanines .....	280
123	Open Web Steel Joists .....	286
124	Roof Platforms .....	295
125	Catwalks & Walkways .....	297
126	Staircases .....	304
127	Handrails .....	312
128	Ladders .....	315
129	Grating .....	318
12.10	Checkered Plates .....	319

Floor systems offered by Zamil Steel include mezzanines, catwalks and walkways with all their components and subsystems such as open web steel joists, grating, checkered plates, staircases and handrails.

The following section describes in full details the components and subsystems of Zamil Steel floor systems. For further information consult any Zamil Steel representative.



A **mezzanine** is an elevated flooring system located inside the outer shell of a pre-engineered steel building. The most common uses of a mezzanine are to accommodate offices or to serve as a storage area. Generally, the mezzanine framing is connected to the main rigid frame columns for lateral stability. Primary and secondary mezzanine members are analyzed as pinned at both ends. Though this design approach may result in a slightly heavier design, it has proven to be safer in the long term due to the possibility that the mezzanine may be partially removed as building layouts change during the lifetime of a structure.

Zamil Steel's standard mezzanine structures consists of built-up or hot rolled main mezzanine beams that support built-up, hot rolled or cold-formed mezzanine joists which, in turn, support a metal deck. A reinforced concrete slab (not supplied by Zamil Steel) is cast on the metal deck as the finished surface.

The metal deck is not designed to carry the floor live loads; it is intended only to carry the reinforced concrete slab during pouring. The reinforced concrete slab must be designed to carry the floor loads.

Standard mezzanine interior stub columns are 150 x 150 mm and 200 x 200 mm tube sections.

When specifying a mezzanine it is important to provide the following information:

- Live load on mezzanine.
- Type of mezzanine finished surface, such as concrete slab, checkered plate, grating, plywood, etc.
- Clear height below the mezzanine beams.
- Clear height between the top of the mezzanine joist and the nearest vertical obstruction.
- Collateral loads supported from the mezzanine structure, such as a suspended ceiling, central air conditioning ducts, plumbing, sprinkler system piping, etc.
- Type and location of partitions over the mezzanine.
- Type of flooring finish such as, tile, vinyl, carpet, etc.
- Location and type (whether single or double flight) of staircases.
- Location of handrails.

In the absence of actual load data, the following loads are used by Zamil Steel when designing mezzanine structures:

Occupancy or Use		Uniform Load (kN/m <sup>2</sup> )
Assembly Halls	Fixed seats	2.50
	Movable seats	5.00
	Stage floor and platforms	5.00
Corridors		5.00
Libraries	Reading rooms	3.00
	Stack rooms	7.50
Maintenance Platform		3.00
Manufacturing	Light	5.00
	Heavy	7.50
Office Buildings	Office	2.50
	Lobbies	5.00
	Computer rooms	5.00
	Corridors above first floor	4.00
Recreation Room		3.75
Schools	Class rooms	2.00
	Corridors	4.00
Stairs and Exitways		5.00
Storage Warehouse	Light	6.25
	Heavy	12.50
Stores	Retail	3.75
	Wholesale	5.00



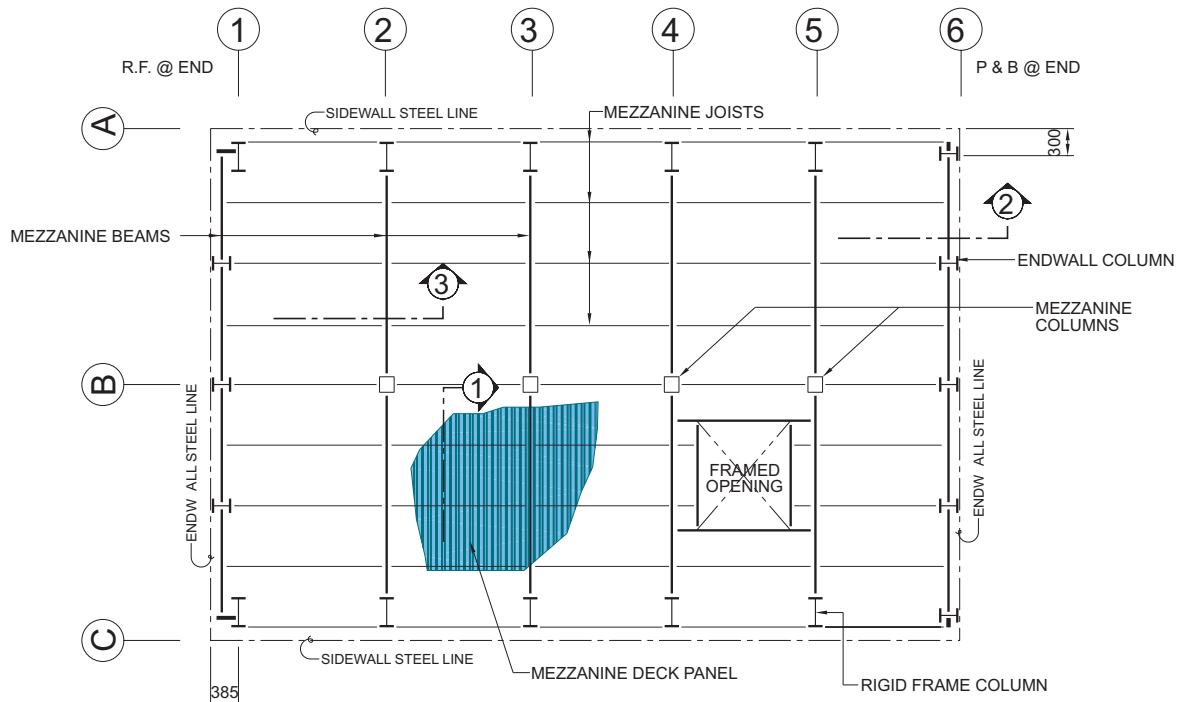

**PLAN: MEZZANINE PLAN (TYPE "A")**

NOTE: 1. TYPE "A" HAS THE MEZZANINE BEAMS PARALLEL TO THE MAIN FRAME RAFTERS.  
 2. FOR DRAWING DETAILS SEE PAGES 4 OF 6 AND 5 OF 6 OF THIS SECTION.

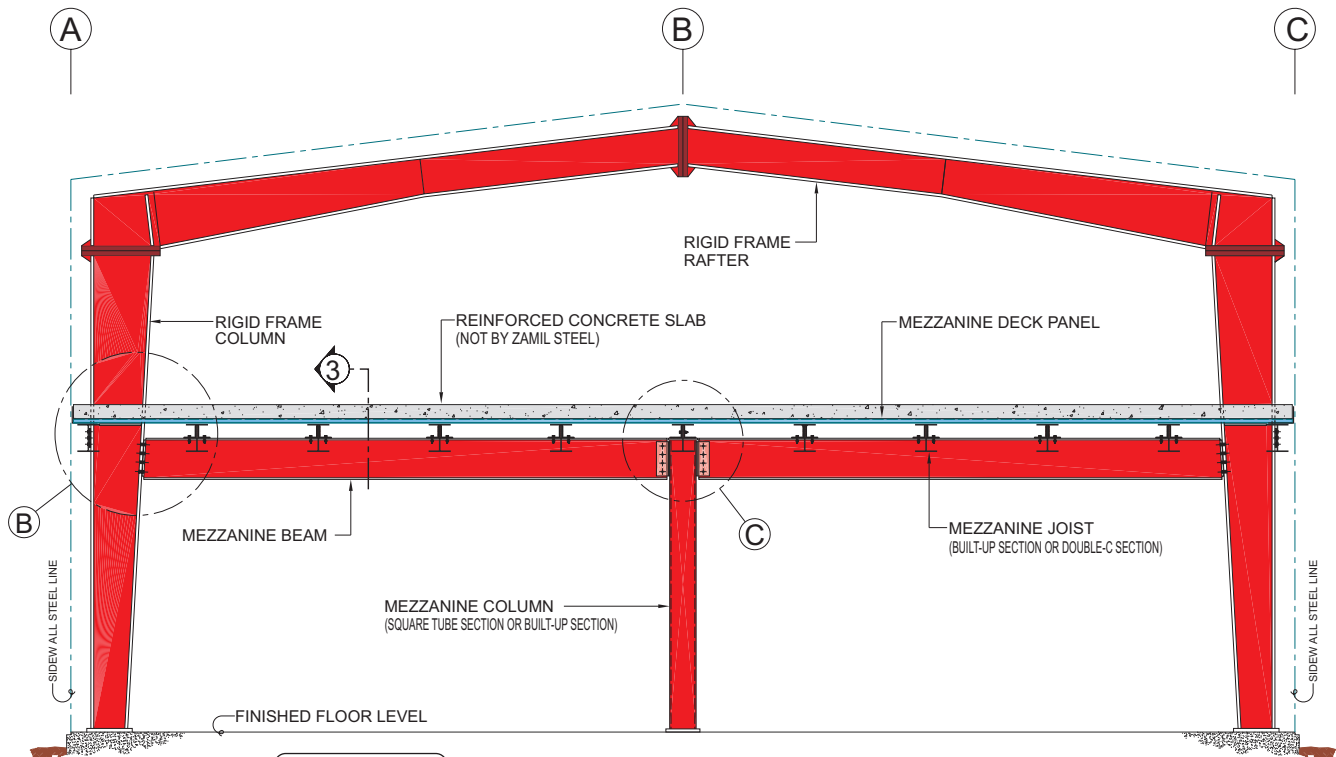

**ELEVATION: MEZZANINE CROSS SECTION (TYPE "A")**

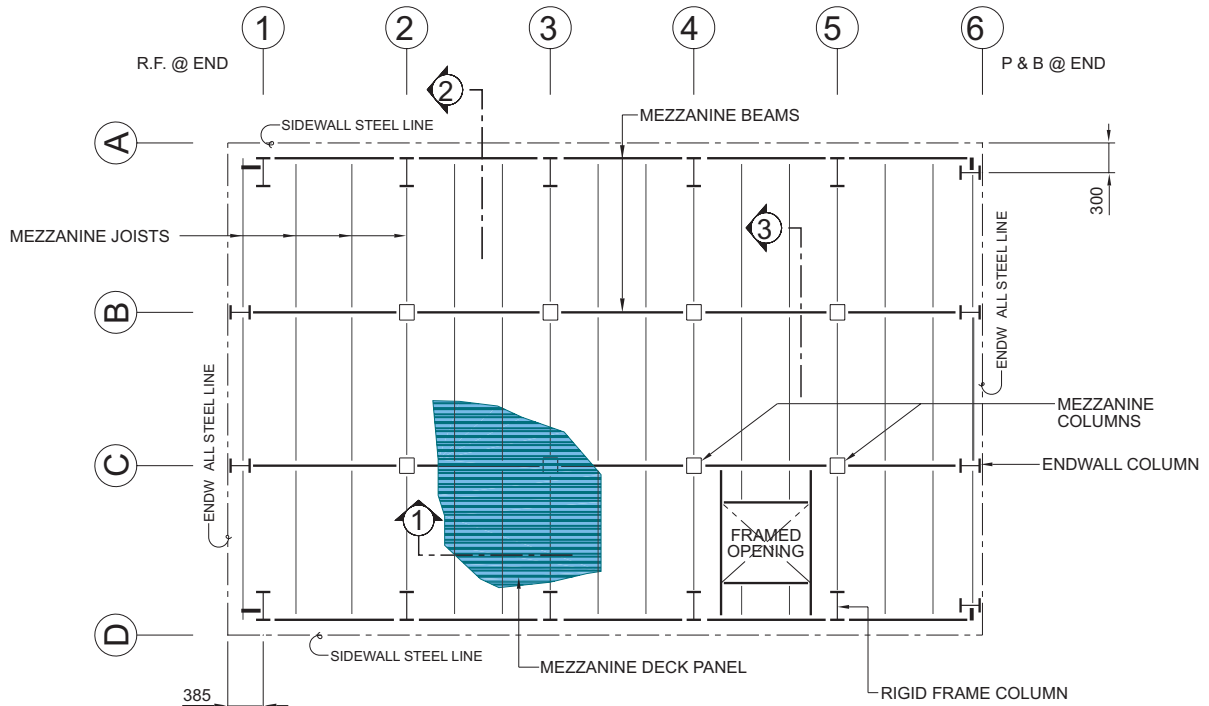

**PLAN** : MEZZANINE PLAN (TYPE "B")

NOTE: 1. TYPE "B" HAS THE MEZZANINE BEAMS PERPENDICULAR TO THE MAIN FRAME RAFTERS.  
2. FOR DRAWING DETAILS SEE PAGES 4 OF 6 AND 5 OF 6 OF THIS SECTION.

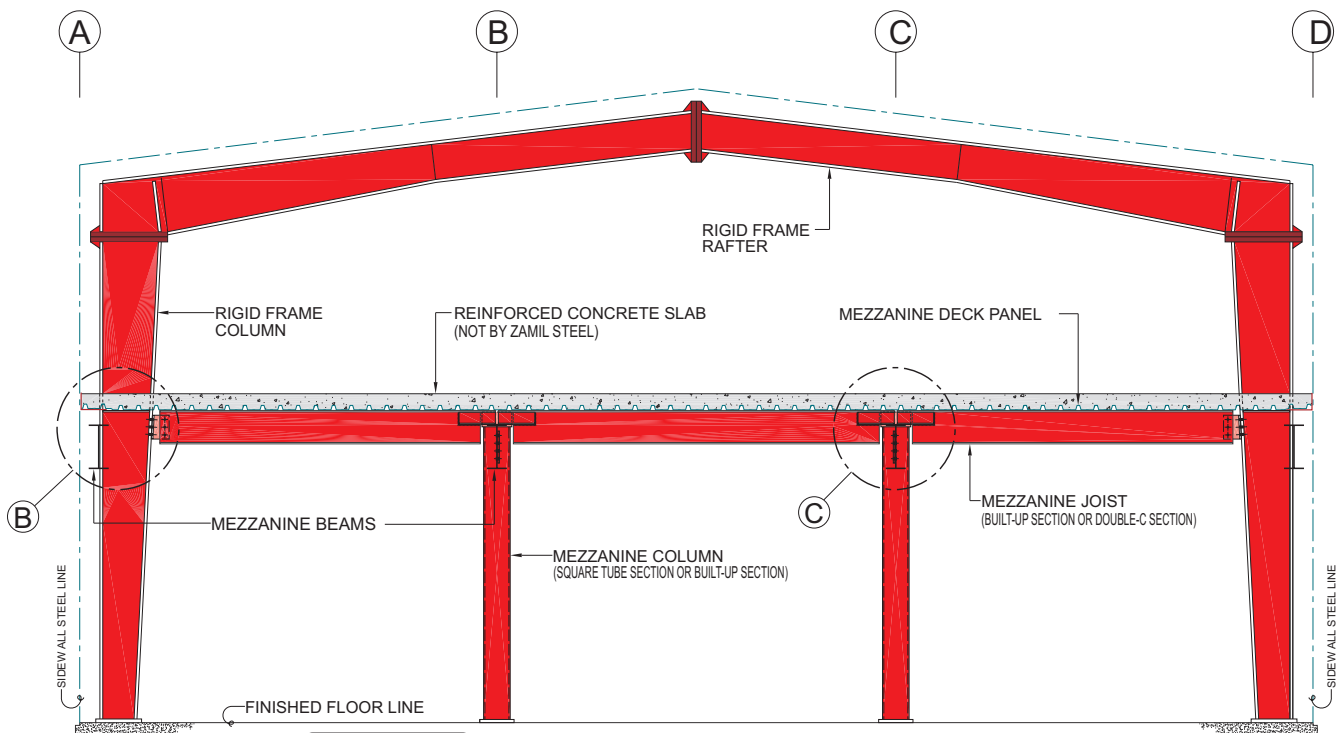

**ELEVATION** : MEZZANINE CROSS SECTION (TYPE "B")

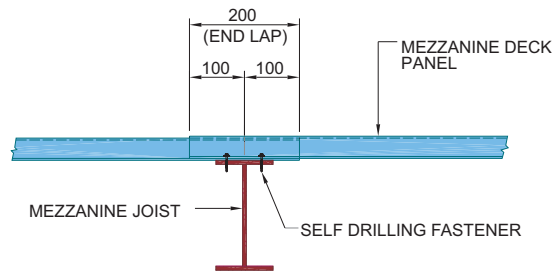

**SECTION-1 : MEZZANINE DECK PANEL END LAP DETAIL**

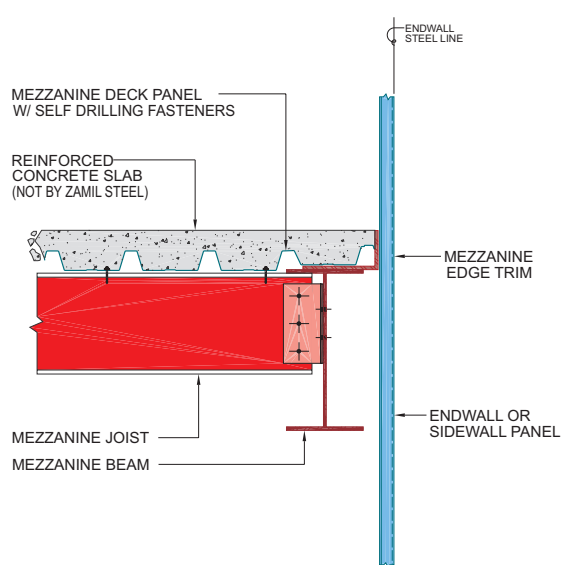

**SECTION-2 : MEZZANINE BEAM AT ENDWALL CONNECTION (FLUSH CONNECTION)**

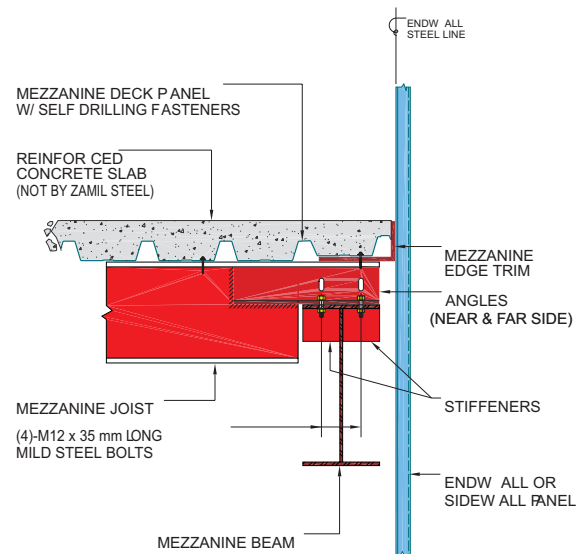

**SECTION-2 : MEZZANINE BEAM AT ENDWALL CONNECTION (RESTING CONNECTION)**

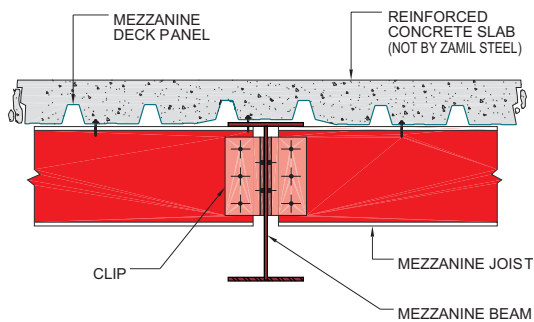

**SECTION-2 : MEZZANINE JOIST TO BEAM CONNECTION (FLUSH CONNECTION)**

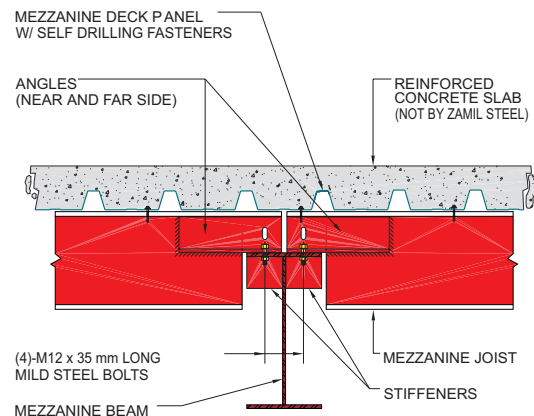

**SECTION-3 : MEZZANINE JOIST TO BEAM CONNECTION (RESTING CONNECTION)**

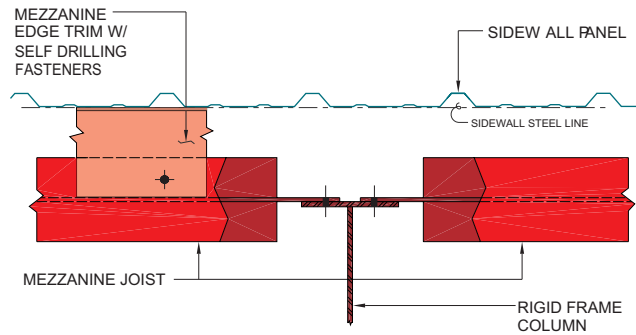

SECTION R

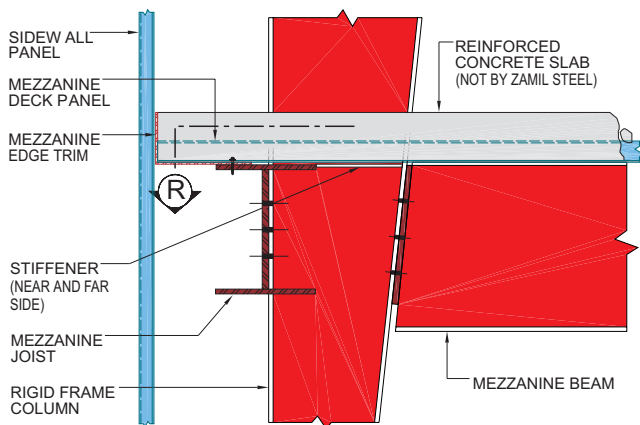

DETAIL-B : BEAM CONNECTION AT R.F. COLUMN  
(FLUSH CONNECTION)

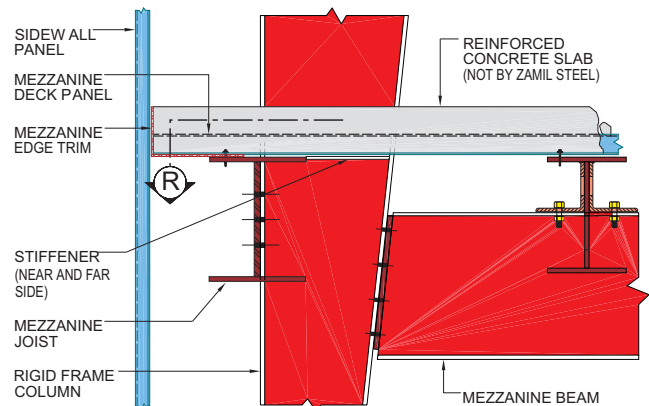

DETAIL-B : BEAM CONNECTION AT R.F. COLUMN  
(RESTING CONNECTION)

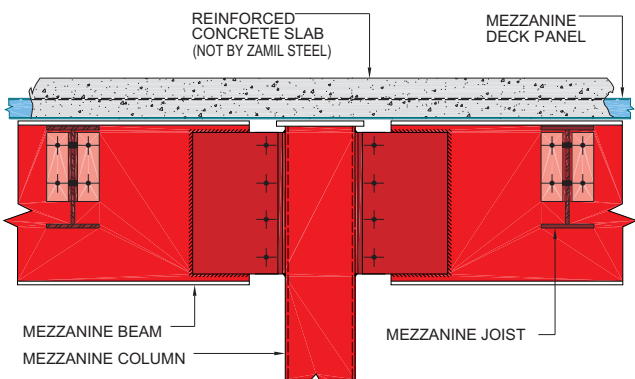

DETAIL-C : MEZZANINE COLUMN CONNECTION  
(FLUSH CONNECTION)

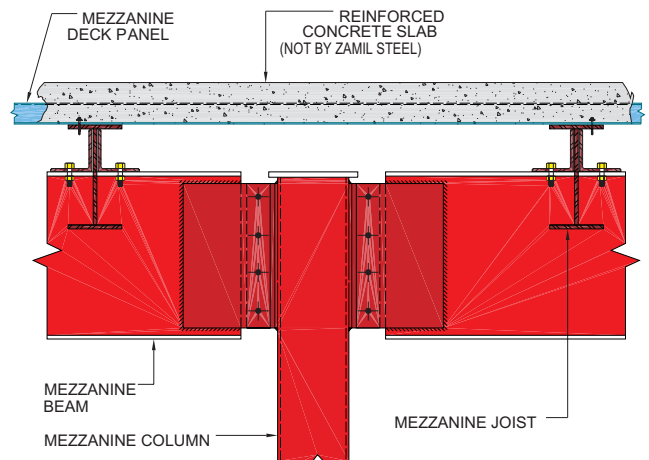

DETAIL-C : MEZZANINE COLUMN CONNECTION  
(RESTING CONNECTION)

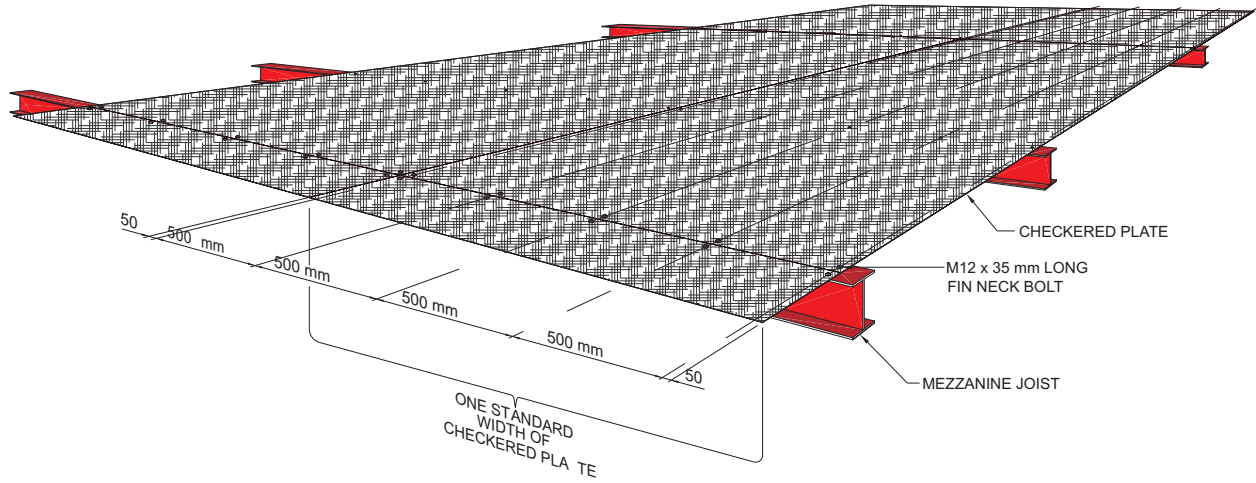

**ISOMETRIC** : MEZZANINE CHECKERED PLATE CONNECTION TO JOIST

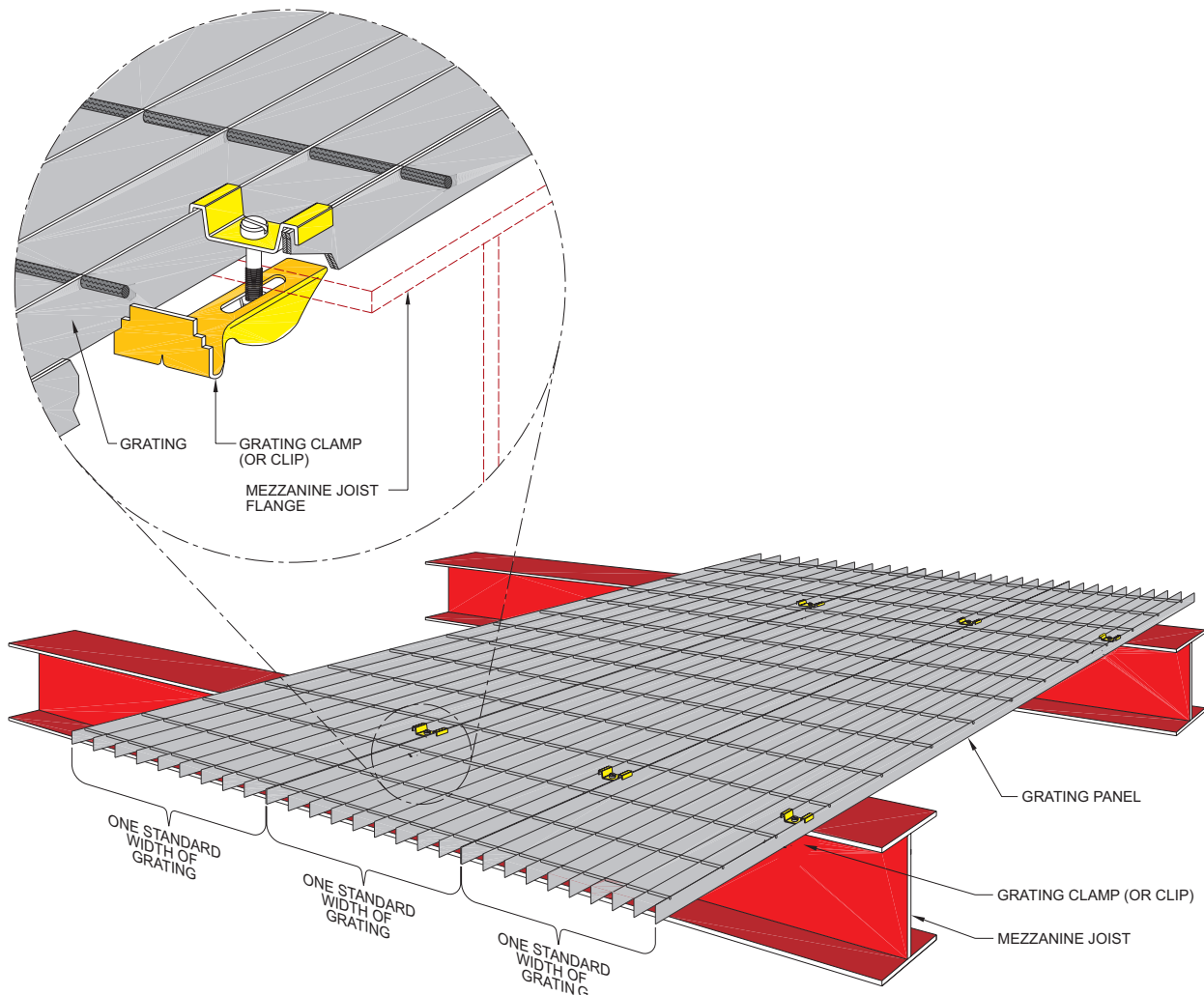

**ISOMETRIC** : MEZZANINE GRATING CONNECTION TO JOIST

Open web steel joists have long been used both as mezzanine joists in multi-storey buildings and as roof secondary members supporting roof sheeting panels and built-up roofs.

**The most common application of open web steel joists is as secondary joist members in multi-storey buildings where they span between the primary framing members of the structure.**

In the pre-engineered steel building industry, the use of open web steel joists, as mezzanine joists, has skyrocketed during the past 10 years. In the U.S.A market, open web steel joists now represent more than 50% of the mezzanine joists used in metal buildings. Their economy and their flexibility are gradually replacing built-up plate joists and cold-formed “C” section joists.

The economy of open web steel joists in mezzanines of pre-engineered steel buildings is realized primarily from savings in their web members. Because their web members are mostly open (webs are made up of angles or rods with large spaces between them), they consume less steel. This feature is exploited further by making their web members deeper. Normally, the selected depth of the joists equals the depth of the primary mezzanine beams between which they span.

Zamil Steel open web steel joists consist of top and bottom chords and diagonal and vertical members. The top and bottom chords are made of hot rolled angles conforming to ASTM A572 Grade 50 (or equivalent) that range in thickness between 3 mm and 6 mm. Web members are made from rods, plain bars or angles.

At Zamil Steel, open web steel joists are designated as follows (SJ stands for Short Span):

- Open web steel joists, which use the same size angles for the top chord and bottom chord.

Depth-SJ - Chord angles size.

**Example:** 600SJ 50x4

- Open web steel joists, which use different size angles for the top chord and bottom chord.

Depth-SJ - Top chord angles size / Bottom chord angles size.

**Example:** 600SJ 50x4/40x4

Zamil Steel may also use round or square bars to replace the chord angles.

Zamil Steel open web joists are designed in accordance with the Steel Joist Institute (SJI), the American Iron and Steel Institute (AISI), and the American Institute of Steel Construction (AISC). All welding is in accordance with the 1996 edition of the American Welding Society (AWS).



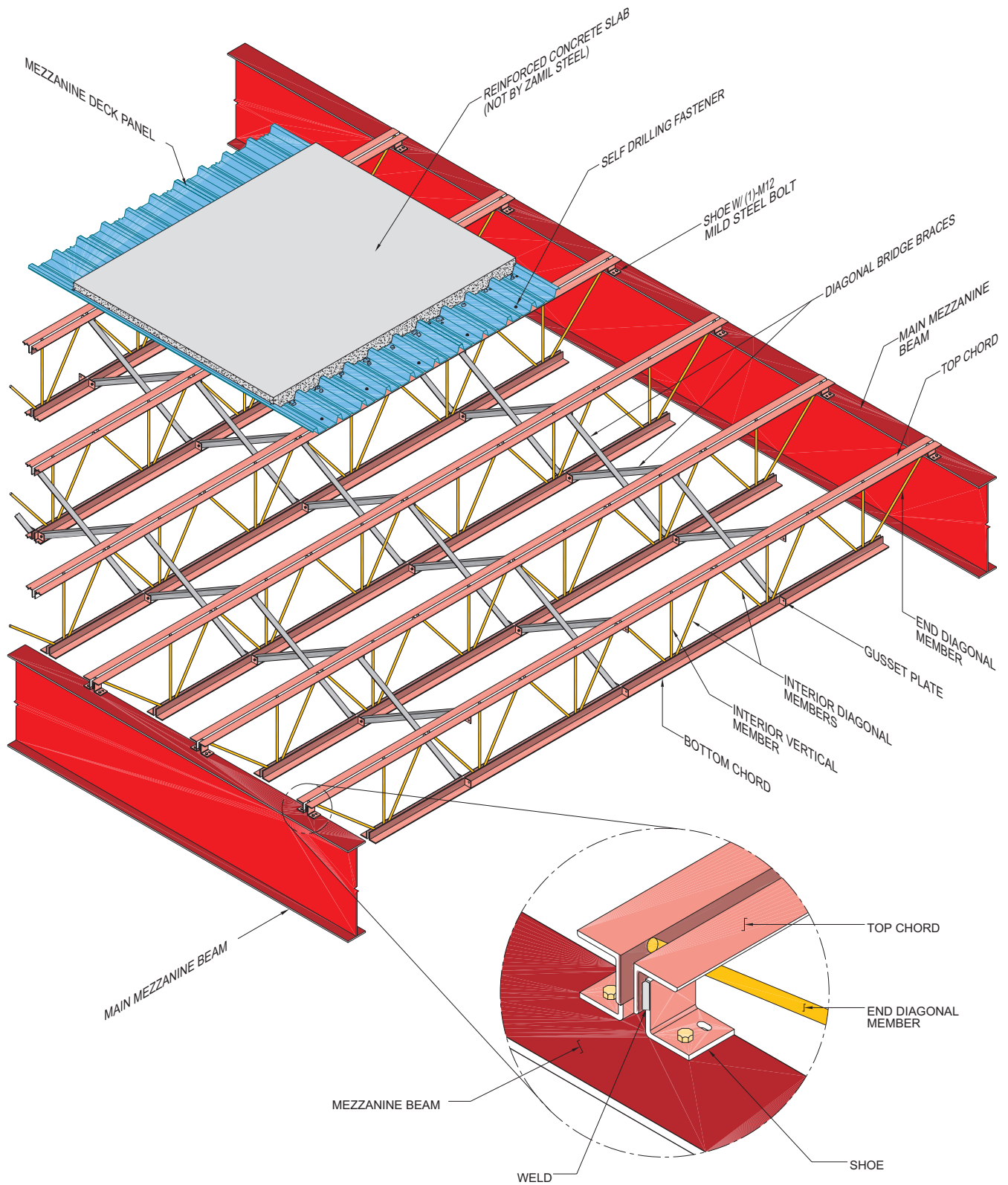

**ISOMETRIC** : TYPICAL CONSTRUCTION OF OPEN WEB JOIST

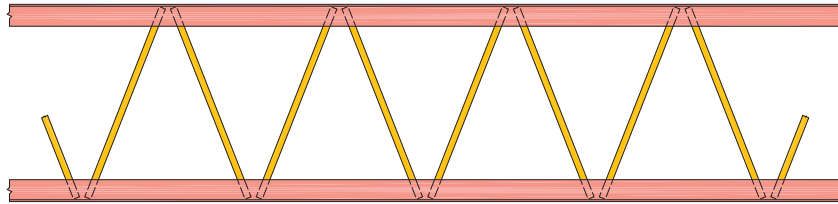

WARREN : SUITABLE FOR SHORT SPANS, LIGHT LOADS

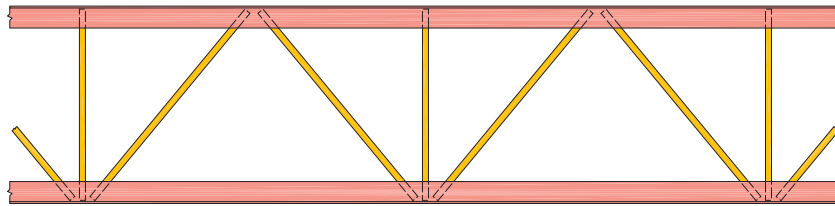

MODIFIED WARREN : SUITABLE FOR LONG SPANS, HEAVY LOADS

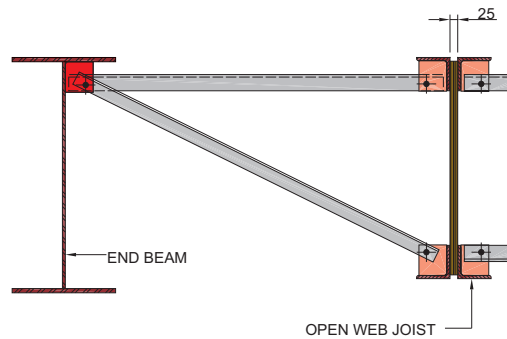

NOTE: ALL BOLTS ARE M12 x 35 mm MILD STEEL BOLTS

END BRIDGING CONNECTION

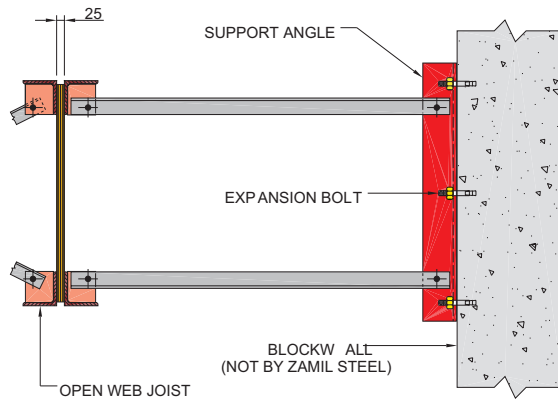

NOTE: ALL BOLTS ARE M12 x 35 mm MILD STEEL BOLTS

PARALLEL BRIDGING  
END CONNECTION W/ CONCRETE

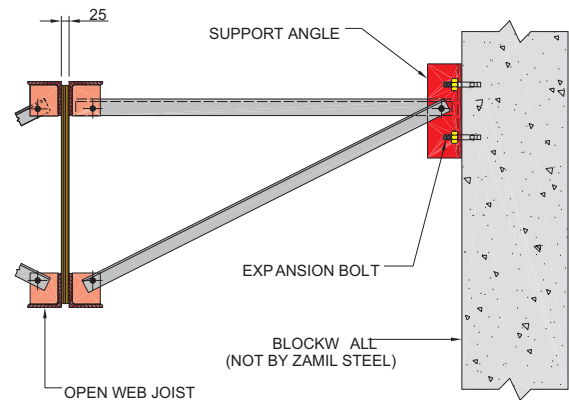

NOTE: ALL BOLTS ARE M12 x 35 mm MILD STEEL BOLTS

DIAGONAL BRIDGING  
END CONNECTION W/ CONCRETE



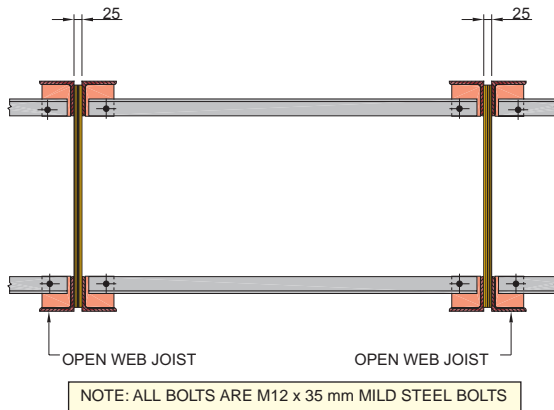

PARALLEL BRIDGING BETWEEN JOISTS

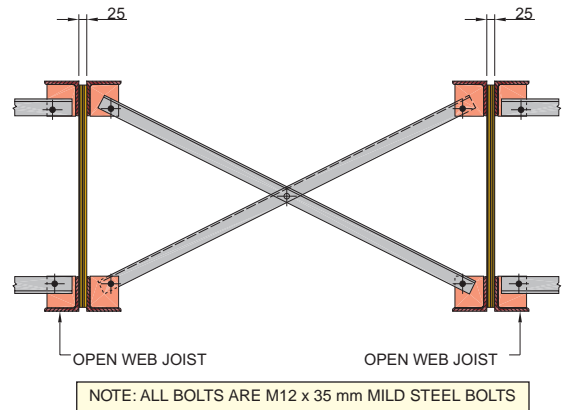

DIAGONAL BRIDGING BETWEEN JOISTS

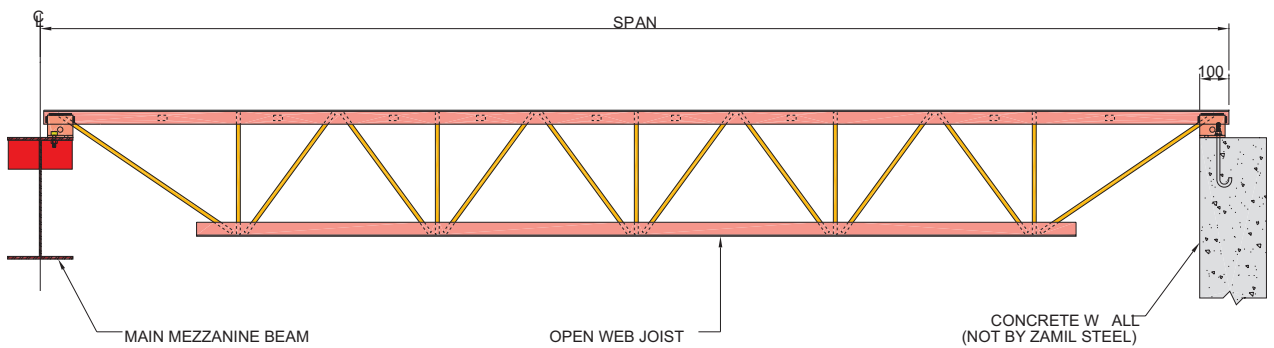

JOIST SUPPORT DETAIL

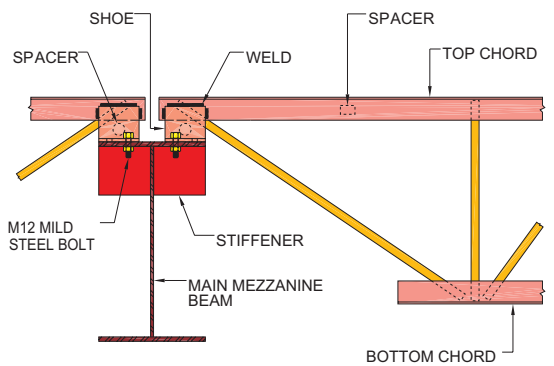

OPEN WEB JOISTS CONNECTION DETAIL AT INTERIOR BEAMS

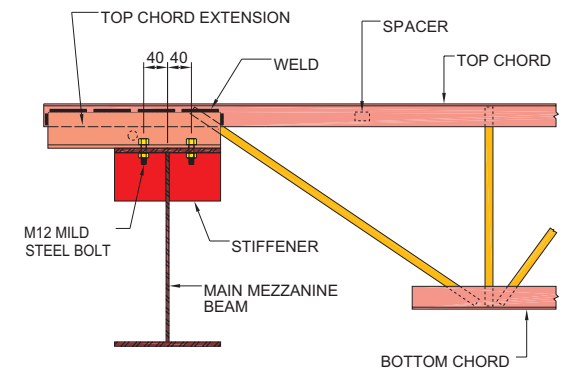

CHORD EXTENSION DETAIL AT ENDS

Joist Span "L" (mm)	Joist Designation & Weight in kg/lm							Depth = 300mm	
	300SJ30x3 7.27	300SJ40x3 9.42	300SJ50x3 11.40	300SJ50x4 14.32	300SJ60x4 16.80	300SJ60x5 20.26	300SJ60x6 23.74	300SJ75x6 29.55	
	Allowable Loads (kN/lm)								
6000	3.05	5.05	6.66	8.75	10.85	13.40	15.85	20.50	
	2.33	3.26	3.99	5.17	6.05	7.33	8.61	10.46	
6500	2.56	4.28	5.58	7.33	9.12	11.23	13.31	17.20	
	1.99	2.78	3.40	4.40	4.92	5.95	7.03	8.40	
7000	2.18	3.56	4.76	6.26	7.75	9.53	11.31	14.58	
	1.47	2.05	2.50	3.24	3.75	4.57	5.34	6.86	
7500	1.89	3.10	4.14	5.43	6.73	8.30	9.85	12.75	
	1.28	1.78	2.18	2.82	3.27	3.98	4.65	5.66	
8000	1.67	2.72	3.62	4.75	5.92	7.29	8.63	11.15	
	1.07	1.49	1.81	2.38	2.65	3.23	3.80	4.64	
8500	1.46	2.35	3.14	4.15	5.16	6.39	7.57	9.75	
	0.83	1.16	1.42	1.85	2.14	2.61	3.06	3.71	
9000	1.28	2.10	2.80	3.70	4.59	5.70	6.75	8.70	
	0.74	1.04	1.27	1.65	1.91	2.33	2.73	3.31	
9500	1.14	1.88	2.51	3.32	4.11	5.07	6.05	7.81	
	0.65	0.91	1.11	1.44	1.70	2.07	2.35	2.85	
10000	0.99	1.69	2.26	2.97	3.69	4.52	5.35	6.95	
	0.53	0.74	0.90	1.16	1.36	1.65	1.94	2.35	
10500	0.90	1.53	2.04	2.69	3.33	4.10	4.85	6.30	
	0.48	0.67	0.82	1.05	1.23	1.50	1.76	2.13	
11000	0.82	1.38	1.85	2.43	3.01	3.71	4.42	5.72	
	0.41	0.58	0.71	0.93	1.09	1.33	1.52	1.84	
11500	0.75	1.25	1.63	2.18	2.72	3.36	3.97	5.17	
	0.34	0.49	0.60	0.77	0.90	1.10	1.29	1.56	
12000	0.68	1.14	1.50	2.00	2.50	3.07	3.64	4.75	
	0.32	0.45	0.55	0.71	0.83	1.01	1.19	1.43	

Joist Span "L" (mm)	Joist Designation & Weight in kg/lm							Depth = 350mm	
	350SJ30x3 7.42	350SJ40x3 9.57	350SJ50x3 11.60	350SJ50x4 14.53	350SJ60x4 17.01	350SJ60x5 20.45	350SJ60x6 24.07	350SJ75x6 29.89	
	Allowable Loads (kN/lm)								
6000	3.60	5.95	7.88	10.35	12.85	15.85	18.80	24.22	
	3.18	4.45	5.46	7.05	8.27	10.03	11.82	14.42	
6500	3.03	4.98	6.58	8.65	10.78	13.30	15.76	20.33	
	2.71	3.79	4.65	6.03	6.72	8.15	9.65	11.80	
7000	2.58	4.25	5.63	7.40	9.18	11.31	13.43	17.32	
	2.02	2.80	3.45	4.44	5.19	6.27	7.38	9.51	
7500	2.23	3.68	4.90	6.43	7.98	9.85	11.70	15.10	
	1.76	2.44	3.00	3.87	4.52	5.46	6.43	7.83	
8000	1.96	3.22	4.28	5.62	7.00	8.64	10.23	13.22	
	1.46	2.05	2.50	3.30	3.65	4.45	5.22	6.45	
8500	1.68	2.80	3.76	4.93	6.11	7.57	8.97	11.55	
	1.15	1.60	1.96	2.54	2.95	3.61	4.23	5.15	
9000	1.50	2.50	3.35	4.37	5.45	6.75	8.00	10.30	
	1.02	1.43	1.75	2.27	2.63	3.22	3.78	4.59	
9500	1.35	2.24	3.00	3.95	4.89	6.03	7.18	9.24	
	0.89	1.25	1.54	2.00	2.36	2.89	3.25	3.95	
10000	1.21	1.98	2.65	3.53	4.35	5.39	6.39	8.27	
	0.72	1.02	1.24	1.61	1.88	2.29	2.69	3.26	
10500	1.09	1.80	2.40	3.18	3.95	4.87	5.77	7.50	
	0.66	0.93	1.13	1.46	1.71	2.08	2.44	2.96	
11000	0.99	1.64	2.19	2.88	3.58	4.44	5.28	6.80	
	0.57	0.81	0.99	1.28	1.53	1.80	2.12	2.57	
11500	0.87	1.47	1.96	2.61	3.23	4.00	4.74	6.15	
	0.48	0.67	0.82	1.07	1.25	1.53	1.79	2.17	
12000	0.80	1.35	1.80	2.40	2.97	3.65	4.35	5.65	
	0.44	0.62	0.76	0.98	1.15	1.40	1.65	2.00	

Total figure represents the maximum allowable **TOTAL** load with no consideration for deflection. (Joist self weight shall not be added).  
 Bottom figure represents the maximum allowable **LIVE** load that results into a deflection - L/360.

Joist Span "L" (mm)	Joist Designation & Weight in kg/lm								Depth = 400mm	
	400SJ30x3 7.57	400SJ40x3 9.74	400SJ50x3 11.92	400SJ50x4 14.74	400SJ60x4 17.22	400SJ60x5 20.84	400SJ60x6 24.42	400SJ75x6 30.62		
	Allowable Loads (kN/lm)									
6000	4.17	6.85	9.07	11.95	14.85	18.30	21.72	28.02		
	4.14	5.80	7.30	9.21	10.77	13.15	15.37	19.00		
6500	3.48	5.75	7.60	10.02	12.45	15.35	18.20	23.50		
	3.40	4.94	6.22	7.45	8.75	10.75	12.50	15.20		
7000	2.98	4.88	6.49	8.55	10.62	13.09	15.55	20.06		
	2.64	3.65	4.50	5.78	6.77	8.24	9.62	12.41		
7500	2.69	4.25	5.65	7.44	9.22	11.40	13.55	17.49		
	2.30	3.18	3.92	5.04	5.90	7.18	8.38	10.29		
8000	2.25	3.73	4.93	6.50	8.10	10.00	11.85	15.30		
	1.92	2.72	3.38	4.36	4.87	5.90	6.90	8.50		
8500	1.96	3.25	4.32	5.72	7.12	8.74	10.37	13.40		
	1.50	2.10	2.58	3.34	3.89	4.72	5.57	6.79		
9000	1.75	2.90	3.85	5.08	6.30	7.80	9.25	11.95		
	1.34	1.87	2.30	2.98	3.47	4.21	4.97	6.05		
9500	1.57	2.60	3.46	4.55	5.65	7.00	8.30	10.73		
	1.18	1.65	2.04	2.62	3.12	3.63	4.25	5.20		
10000	1.38	2.32	3.09	4.08	5.05	6.23	7.44	9.59		
	0.95	1.34	1.64	2.12	2.47	3.02	3.55	4.31		
10500	1.25	2.10	2.80	3.70	4.60	5.65	6.70	8.70		
	0.86	1.21	1.48	1.93	2.24	2.74	3.22	3.91		
11000	1.14	1.91	2.55	3.35	4.15	5.15	6.12	7.90		
	0.75	1.05	1.32	1.70	2.02	2.35	2.78	3.40		
11500	1.03	1.72	2.29	3.02	3.76	4.65	5.55	7.13		
	0.62	0.89	1.09	1.41	1.65	2.01	2.37	2.88		
12000	0.92	1.58	2.10	2.79	3.45	4.25	5.05	6.55		
	0.57	0.82	1.00	1.30	1.51	1.85	2.17	2.64		

Joist Span "L" (mm)	Joist Designation & Weight in kg/lm								Depth = 450mm	
	450SJ30x3 7.74	450SJ40x3 9.95	450SJ50x3 12.17	450SJ50x4 15.00	450SJ60x4 17.69	450SJ60x5 21.39	450SJ60x6 25.08	450SJ75x6 31.06		
	Allowable Loads (kN/lm)									
6000	4.75	6.05	7.35	9.60	16.85	20.80	24.65	31.85		
	4.70	6.00	6.83	8.84	13.70	16.63	19.55	23.90		
6500	3.95	5.16	6.26	8.18	14.15	17.42	20.60	26.70		
	3.90	5.14	5.82	7.53	10.95	13.45	15.55	19.30		
7000	3.39	4.30	5.22	6.89	12.05	14.87	17.62	22.73		
	3.33	3.85	4.35	5.55	8.48	10.33	12.25	15.80		
7500	2.92	3.75	4.55	6.00	10.50	12.95	15.35	19.85		
	2.90	3.35	3.79	4.84	7.39	9.00	10.67	12.99		
8000	2.55	3.30	4.00	5.27	9.20	11.35	13.45	17.40		
	2.46	2.94	3.33	4.25	6.12	7.45	8.75	10.70		
8500	2.24	2.86	3.48	4.60	8.07	9.98	11.83	15.25		
	1.91	2.21	2.50	3.21	4.93	5.99	7.02	8.62		
9000	2.00	2.55	3.10	4.10	7.15	8.90	10.55	13.60		
	1.70	1.97	2.23	2.86	4.39	5.35	6.26	7.69		
9500	1.79	2.29	2.78	3.68	6.42	7.99	9.47	12.21		
	1.50	1.77	2.00	2.57	3.94	4.55	5.40	6.60		
10000	1.59	2.04	2.48	3.25	5.75	7.11	8.43	10.91		
	1.21	1.41	1.60	2.05	3.14	3.81	4.48	5.49		
10500	1.44	1.85	2.25	2.95	5.20	6.44	7.65	9.90		
	1.10	1.28	1.45	1.86	2.85	3.46	4.07	4.98		
11000	1.32	1.69	2.05	2.69	4.75	5.88	6.97	9.02		
	0.95	1.16	1.32	1.70	2.59	3.00	3.52	4.32		
11500	1.17	1.52	1.85	2.45	4.29	5.30	6.32	8.17		
	0.80	0.93	1.06	1.37	2.10	2.56	3.00	3.68		
12000	1.07	1.40	1.70	2.25	3.95	4.85	5.80	7.50		
	0.74	0.86	0.98	1.26	1.93	2.35	2.76	3.38		

Top figure represents the maximum allowable **TOTAL** load with no consideration for deflection. (Joist self weight shall not be added).

Bottom figure represents the maximum allowable **LIVE** load that results into a deflection - L/360.

Joist Span "L" (mm)	Joist Designation & Weight in kg/lm							
	Depth = 500mm							
	500SJ30x3 7.91	500SJ40x3 10.28	500SJ50x3 12.35	500SJ50x4 15.36	500SJ60x4 18.15	500SJ60x5 21.81	500SJ60x6 25.69	500SJ75x6 31.69
Allowable Loads (kN/lm)								
6000	5.29	8.67	10.75	14.45	18.85	23.25	27.60	35.69
	5.00	8.36	10.69	13.38	16.70	20.22	23.85	29.04
6500	4.42	7.27	9.16	12.31	15.82	19.50	23.15	29.90
	4.40	7.13	9.11	11.40	13.50	16.30	19.30	23.50
7000	3.79	5.85	7.69	10.33	13.49	16.65	19.74	25.60
	3.70	5.32	6.82	8.44	10.41	12.67	14.90	18.30
7500	3.20	5.10	6.70	9.00	11.75	14.50	17.20	22.30
	3.00	4.63	5.94	7.35	9.07	11.04	12.98	15.94
8000	2.85	4.48	5.89	7.91	10.30	12.72	15.05	19.50
	2.80	4.07	5.22	6.46	7.50	9.15	10.65	13.10
8500	2.52	3.92	5.16	6.95	9.02	11.16	13.23	17.15
	2.34	3.07	3.94	4.87	6.05	7.33	8.62	10.62
9000	2.22	3.50	4.60	6.20	8.02	9.95	11.80	15.29
	2.09	2.74	3.51	4.34	5.40	6.54	7.69	9.47
9500	2.00	3.14	4.13	5.56	7.22	8.93	10.59	13.73
	1.85	2.46	3.05	3.90	4.85	5.87	6.65	8.10
10000	1.76	2.81	3.69	4.96	6.45	7.99	9.48	12.29
	1.49	1.97	2.52	3.12	3.87	4.70	5.52	6.77
10500	1.60	2.55	3.35	4.50	5.85	7.25	8.60	11.15
	1.35	1.79	2.29	2.83	3.51	4.26	5.01	6.14
11000	1.46	2.32	3.05	4.10	5.25	6.58	7.82	10.12
	1.20	1.63	2.07	2.58	3.20	3.70	4.30	5.30
11500	1.31	2.07	2.72	3.70	4.82	5.92	7.08	9.15
	0.99	1.32	1.69	2.09	2.59	3.15	3.71	4.55
12000	1.20	1.90	2.50	3.40	4.40	5.50	6.50	8.40
	0.91	1.21	1.55	1.92	2.38	2.89	3.41	4.18

Joist Span "L" (mm)	Joist Designation & Weight in kg/lm							
	Depth = 550mm							
	550SJ30x3 8.12	550SJ40x3 10.54	550SJ50x3 12.72	550SJ50x4 15.84	550SJ60x4 18.47	550SJ60x5 22.25	550SJ60x6 26.22	550SJ75x6 32.93
Allowable Loads (kN/lm)								
6000	5.82	9.10	11.85	16.00	20.85	25.75	30.55	39.50
	5.80	9.10	11.85	15.83	19.82	23.90	28.32	35.31
6500	4.88	7.60	9.95	13.63	17.50	21.55	25.60	32.80
	4.85	7.60	9.95	13.49	15.90	19.20	22.60	28.90
7000	4.19	6.49	8.50	11.48	14.92	18.42	21.87	28.35
	4.19	6.34	8.50	10.04	12.38	15.09	17.74	21.79
7500	3.60	5.65	7.40	10.00	13.00	16.05	19.05	24.70
	3.55	5.52	7.05	8.75	10.79	13.14	15.30	18.98
8000	3.15	4.97	6.50	8.79	11.40	14.05	16.68	21.62
	3.15	4.85	6.20	7.69	8.90	10.90	12.90	15.90
8500	2.80	4.37	5.66	7.68	10.03	12.39	14.69	19.00
	2.80	3.69	4.71	5.88	7.00	8.79	10.36	12.71
9000	2.45	3.90	5.05	6.85	8.95	11.02	13.10	16.95
	2.45	3.29	4.20	5.25	6.44	7.84	9.24	11.33
9500	2.22	3.50	4.53	6.15	8.00	9.92	11.76	15.21
	2.16	2.95	3.77	4.71	5.78	6.50	7.90	9.70
10000	1.98	3.09	4.08	5.51	7.15	8.88	10.53	13.62
	1.79	2.37	3.03	3.74	4.64	5.63	6.61	8.12
10500	1.78	2.80	3.70	5.00	6.48	8.05	9.55	12.35
	1.63	2.15	2.75	3.39	4.21	5.11	5.99	7.37
11000	1.62	2.55	3.37	4.56	5.85	7.30	8.65	11.10
	1.45	1.96	2.51	3.09	3.83	4.40	5.25	6.40
11500	1.47	2.29	3.05	4.08	5.34	6.64	7.84	10.18
	1.20	1.58	2.04	2.52	3.12	3.80	4.47	5.47
12000	1.30	2.10	2.80	3.75	4.90	6.05	7.20	9.35
	1.10	1.46	1.87	2.31	2.86	3.49	4.11	5.03

Top figure represents the maximum allowable **TOTAL** load with no consideration for deflection. (Joist self weight shall not be added).  
 Bottom figure represents the maximum allowable **LIVE** load that results into a deflection - L/360.

Joist Span "L" (mm)	Joist Designation & Weight in kg/lm								Depth = 600mm	
	600SJ30x3 8.34	600SJ40x3 10.75	600SJ50x3 13.13	600SJ50x4 16.25	600SJ60x4 18.94	600SJ60x5 22.77	600SJ60x6 26.96	600SJ75x6 33.61		
	Allowable Loads (kN/lm)									
6000	6.40	9.50	13.00	17.55	22.90	28.25	33.50	43.20		
	6.40	9.50	13.00	17.55	22.90	27.82	33.10	41.02		
6500	5.35	8.09	11.08	14.70	19.20	23.50	28.00	36.00		
	5.35	8.09	11.08	14.70	18.55	22.70	27.80	34.00		
7000	4.59	7.12	9.30	12.51	16.42	20.20	23.99	30.94		
	4.59	7.12	9.30	11.71	14.44	17.59	20.62	26.59		
7500	3.90	6.20	8.10	10.90	14.30	17.60	20.90	27.10		
	3.90	6.20	8.10	10.20	12.58	15.32	17.96	22.22		
8000	3.45	5.45	7.12	9.58	12.50	15.40	18.20	23.60		
	3.45	5.31	6.79	8.96	10.50	12.60	14.90	18.50		
8500	3.03	4.76	6.22	8.41	10.99	13.57	16.09	20.85		
	3.03	4.33	5.56	6.89	8.54	10.34	12.16	14.94		
9000	2.70	4.25	5.55	7.50	9.80	12.10	14.35	18.60		
	2.70	3.86	4.96	6.14	7.62	9.22	10.85	13.33		
9500	2.40	3.81	4.98	6.73	8.80	10.86	12.88	16.69		
	2.35	3.47	4.45	5.51	6.50	8.00	9.20	11.40		
10000	2.15	3.42	4.47	6.01	7.88	9.70	11.50	14.94		
	2.10	2.80	3.57	4.42	5.47	6.64	7.76	9.55		
10500	1.95	3.10	4.05	5.45	7.15	8.80	10.40	13.55		
	1.92	2.54	3.24	4.01	4.85	6.02	7.04	8.66		
11000	1.78	2.82	3.96	4.97	6.42	8.02	9.50	12.10		
	1.70	2.31	2.95	3.65	4.52	5.25	6.00	7.50		
11500	1.60	2.56	3.32	4.52	5.85	7.30	8.66	11.22		
	1.42	1.88	2.40	2.98	3.68	4.49	5.26	6.49		
12000	1.45	2.35	3.05	4.15	5.35	6.70	7.95	10.20		
	1.30	1.73	2.21	2.74	3.38	4.12	4.83	5.96		

Joist Span "L" (mm)	Joist Designation & Weight in kg/lm								Depth = 650mm	
	650SJ30x3 8.54	650SJ40x3 11.26	650SJ50x3 13.46	650SJ50x4 16.70	650SJ60x4 19.48	650SJ60x5 23.52	650SJ60x6 27.48	650SJ75x6 34.67		
	Allowable Loads (kN/lm)									
6000	6.95	10.80	14.15	19.05	24.90	30.70	36.45	47.20		
	6.95	10.80	14.15	19.05	24.90	30.70	36.45	47.20		
6500	5.80	9.20	12.06	16.23	20.85	25.75	30.55	39.60		
	5.80	9.20	12.06	16.23	20.85	25.75	30.55	38.25		
7000	4.99	7.75	10.16	13.85	18.05	22.30	26.45	34.11		
	4.99	7.75	10.16	13.50	17.43	21.18	24.96	31.20		
7500	4.20	6.75	8.85	11.90	15.55	19.20	22.60	29.50		
	4.20	6.75	8.85	11.79	14.46	17.68	20.68	25.61		
8000	3.70	5.93	7.75	10.46	13.60	16.80	19.70	25.80		
	3.70	5.93	7.75	10.36	12.00	14.60	17.10	21.40		
8500	3.31	5.21	6.85	9.14	11.94	14.74	17.55	22.70		
	3.31	5.02	6.72	7.97	9.82	11.95	14.03	17.28		
9000	2.95	4.65	6.05	8.15	10.65	13.15	15.65	20.25		
	2.95	4.48	5.73	7.11	8.76	10.66	12.52	15.42		
9500	2.65	4.17	5.43	7.31	9.56	11.80	14.05	18.17		
	2.65	4.02	5.14	6.38	7.55	9.20	10.70	13.10		
10000	2.30	3.69	4.85	6.56	8.60	10.58	12.57	16.32		
	2.30	3.25	4.13	5.12	6.33	7.65	9.00	11.07		
10500	2.12	3.35	4.40	5.95	7.80	9.60	11.40	14.80		
	2.12	2.95	3.74	4.64	5.74	6.94	8.16	10.04		
11000	1.90	3.05	4.01	5.42	7.05	8.75	10.20	13.20		
	1.90	2.69	3.41	4.23	5.00	6.10	7.10	8.70		
11500	1.75	2.78	3.65	4.90	6.42	7.95	9.42	12.20		
	1.71	2.19	2.79	3.46	4.29	5.19	6.10	7.50		
12000	1.60	2.55	3.35	4.50	5.90	7.30	8.65	11.20		
	1.52	2.01	2.56	3.18	3.94	4.77	5.61	6.89		

Top figure represents the maximum allowable **TOTAL** load with no consideration for deflection. (Joist self weight shall not be added).  
 Bottom figure represents the maximum allowable **LIVE** load that results into a deflection - L/360.

Joist Span "L" (mm)	Joist Designation & Weight in kg/m								Depth = 700mm
	700SJ30x3 8.81	700SJ40x3 11.48	700SJ50x3 13.90	700SJ50x4 16.93	700SJ60x4 19.90	700SJ60x5 24.05	700SJ60x6 28.37	700SJ75x6 35.42	
	Allowable Loads (kN/m)								
6000	7.50	11.70	15.25	20.60	26.90	33.20	39.40	51.10	
	7.50	11.70	15.25	20.60	26.90	33.20	39.40	51.10	
6500	6.25	9.97	12.99	17.55	22.55	27.85	33.00	42.80	
	6.25	9.97	12.99	17.55	22.55	27.85	33.00	42.80	
7000	5.40	8.38	10.96	14.75	19.29	23.82	28.24	36.62	
	5.40	8.38	10.96	14.75	19.29	23.01	26.84	33.24	
7500	4.65	7.30	9.55	12.85	16.80	20.75	24.60	31.90	
	4.65	7.30	9.55	12.85	16.60	20.04	23.38	29.06	
8000	4.06	6.42	8.39	11.29	14.75	18.15	21.55	27.90	
	4.06	6.42	8.39	11.29	14.75	16.60	19.20	24.00	
8500	3.59	5.61	7.34	9.92	12.95	15.98	19.00	24.61	
	3.59	5.61	7.29	9.06	11.19	13.41	15.95	19.87	
9000	3.10	5.00	6.55	8.85	11.55	14.25	16.90	21.95	
	3.10	5.00	6.50	8.08	9.98	11.96	14.23	17.73	
9500	2.85	4.49	5.88	7.94	10.37	12.79	15.21	19.70	
	2.85	4.49	5.83	7.25	8.60	10.40	12.30	15.10	
10000	2.54	4.02	5.24	7.11	9.26	11.47	13.62	17.64	
	2.54	3.73	4.72	5.84	7.20	8.72	10.22	12.68	
10500	2.30	3.65	4.75	6.45	8.40	10.40	12.35	16.00	
	2.30	3.38	4.28	5.30	6.53	7.91	9.27	11.50	
11000	2.10	3.33	4.33	5.88	7.65	9.45	11.20	14.55	
	2.10	3.08	3.90	4.83	5.70	7.00	8.20	10.00	
11500	1.90	2.99	3.92	5.34	6.97	8.60	10.18	13.23	
	1.90	2.52	3.20	3.96	4.91	5.97	6.97	8.62	
12000	1.74	2.75	3.60	4.90	6.40	7.90	9.35	12.15	
	1.74	2.31	2.94	3.64	4.51	5.48	6.40	7.92	

Joist Span "L" (mm)	Joist Designation & Weight in kg/m								Depth = 750mm
	750SJ30x3 9.06	750SJ40x3 11.84	750SJ50x3 14.16	750SJ50x4 17.64	750SJ60x4 20.68	750SJ60x5 25.20	750SJ60x6 28.95	750SJ75x6 36.39	
	Allowable Loads (kN/m)								
6000	8.05	12.55	16.40	22.15	28.90	35.70	42.34	54.90	
	8.05	12.55	16.40	22.15	28.90	35.70	42.34	54.90	
6500	6.75	10.69	13.97	18.87	24.20	29.90	35.50	46.00	
	6.75	10.69	13.97	18.87	24.20	29.90	35.50	46.00	
7000	5.74	9.01	11.77	15.90	20.72	25.60	30.70	39.43	
	5.74	9.01	11.77	15.90	20.72	25.60	30.70	39.43	
7500	5.00	7.85	10.25	13.85	18.05	22.30	26.45	34.35	
	5.00	7.85	10.25	13.85	18.05	22.30	26.31	32.69	
8000	4.39	6.90	9.01	12.17	15.81	19.55	23.20	29.90	
	4.39	6.90	9.01	12.17	15.33	18.58	22.40	28.30	
8500	3.87	6.05	7.90	10.65	13.90	17.21	20.40	26.46	
	3.87	6.05	7.90	10.16	12.55	15.17	17.89	22.26	
9000	3.40	5.40	7.05	9.50	12.40	15.35	18.20	23.60	
	3.40	5.40	7.05	9.06	11.20	13.53	15.96	19.86	
9500	3.00	4.85	6.33	8.53	11.13	13.78	16.33	21.18	
	3.00	4.85	6.33	8.13	9.70	11.60	13.80	17.00	
10000	2.70	4.30	5.62	7.66	9.98	12.35	14.66	18.80	
	2.70	4.30	5.54	6.62	8.13	9.84	11.51	14.24	
10500	2.45	3.90	5.10	6.95	9.05	11.20	13.30	17.25	
	2.45	3.82	4.85	6.00	7.37	8.93	10.44	12.92	
11000	2.25	3.55	4.65	6.33	8.25	10.15	12.05	15.65	
	2.25	3.48	4.42	5.47	6.30	7.80	9.20	11.40	
11500	2.00	3.21	3.92	5.72	7.46	9.26	10.94	14.21	
	2.00	2.85	3.20	4.50	5.56	6.72	7.85	9.73	
12000	1.85	2.95	3.60	5.25	6.85	8.50	10.05	13.05	
	1.85	2.62	2.94	4.13	5.10	6.17	7.21	8.94	

Top figure represents the maximum allowable **TOTAL** load with no consideration for deflection. (Joist self weight shall not be added).

Bottom figure represents the maximum allowable **LIVE** load that results into a deflection -  $L/360$ .

A **roof platform** is a structural framing system mounted on top of the roof and is specifically designed to support heavy roof accessories, such as HVAC units, water tanks and other miscellaneous roof equipment.

Zamil Steel's standard roof platforms are made of hot rolled, built-up or cold-formed sections supported by built-up or tube stub post sections, which are bolted to the top of the rafter flanges. Bracing is sometimes provided in both directions to ensure the stability of the framing system.

Roof platforms are designed in such a way so as to permit the removal of the roof sheeting, if so desired, with minimum effort. When a platform is required to support equipment it is recommended that it be large enough to provide access around the equipment for future maintenance of the equipment.

Roof platforms differ from roof framed openings. Roof framed openings generally support lighter equipment that does not require frequent maintenance.

When multiple platforms are required, it is advisable to connect them with elevated walkways, (see **section 12.5**) which will prevent panel damage by maintenance personnel.

The provision of handrails for roof platforms is optional and should be specified at the time of requesting a quotation. See **section 12.7** for more details on handrails.

When ordering roof platforms it is advisable that special attention is paid to water leakage prevention details. Zamil Steel has had extensive experience in supplying roof platforms and in developing details that prevent water leakage.



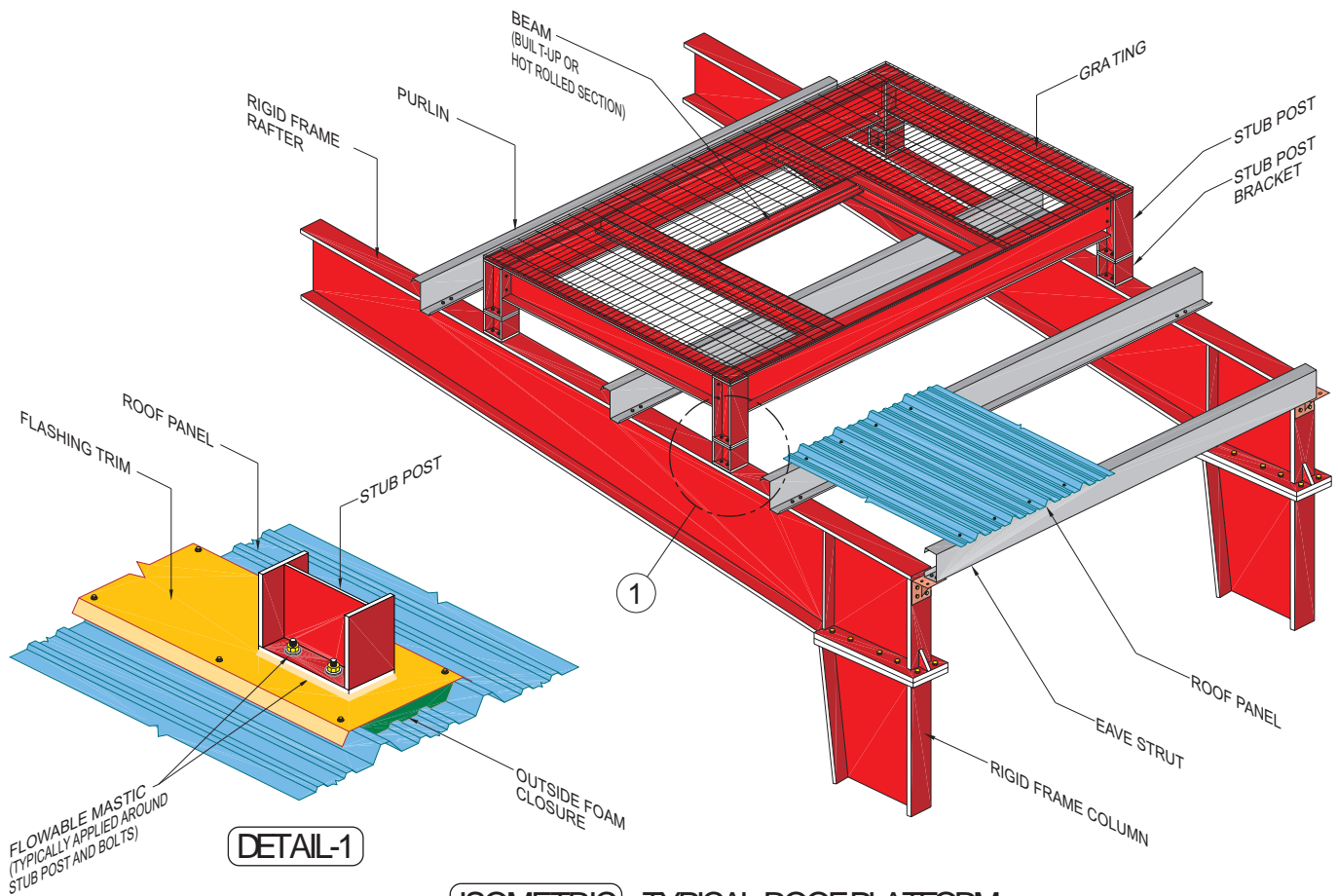

ISOMETRIC : TYPICAL ROOF PLATFORM

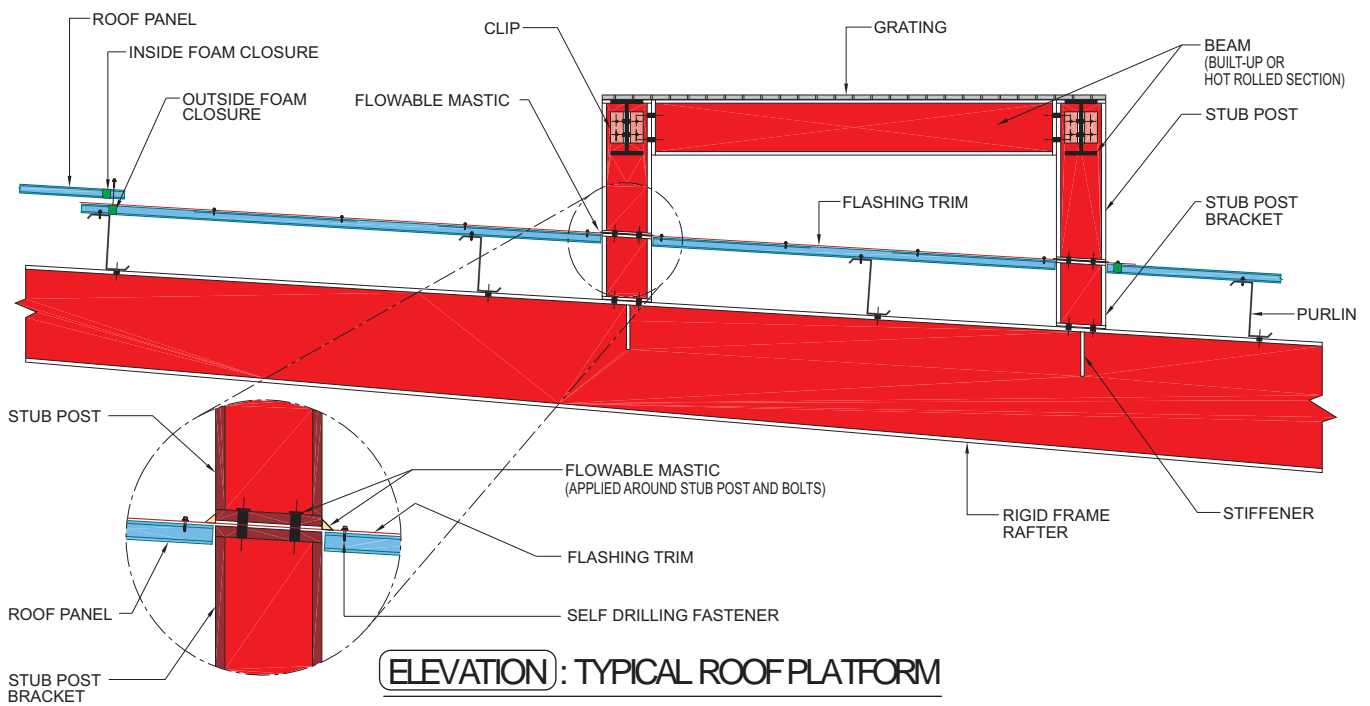

ELEVATION : TYPICAL ROOF PLATFORM



Zamil Steel offers the following types of **catwalks** and **walkways** which are used primarily by maintenance crews to provide access to mechanical equipment:

- **Catwalks** that are normally located inside the building alongside crane beams or suspended underneath rigid frame rafters.
- **Elevated walkways** that are placed directly above the building roof, whenever very frequent access is required between several roof platforms.
- **Flush walkways** that are also placed above the building roof, whenever less frequent access is required for maintenance.

In most buildings, access to the roof is limited to a few external or internal locations. When the access to a roof is external, walkways (elevated or flush) are laid between the initial access point to the roof and the equipment-supporting platforms on the roof.

It is highly recommended to consider the provision of walkways early in the design stage of pre-engineered steel buildings. Roof sheeting is not intended to support very frequent access and may be damaged if service men are not aware of its limitations. When heavy equipment is supported on roof platforms, access to those platforms should

be properly laid out to avoid causing damage to the roof sheets, which in turn may result in roof leaks.

When walking on roof sheeting, care must be taken not to step on the high rib portion of the roof sheeting profile.

Catwalks and elevated walkways are generally provided with handrails for safety purposes (refer to **section 12.7** of this manual for more details on handrails). Decking for catwalks and walkways can be either galvanized grating or checkered plates.

Zamil Steel catwalks and walkways have two standard widths: 1000 mm and 2000 mm. Other sizes are also available depending on the customer's requirements.



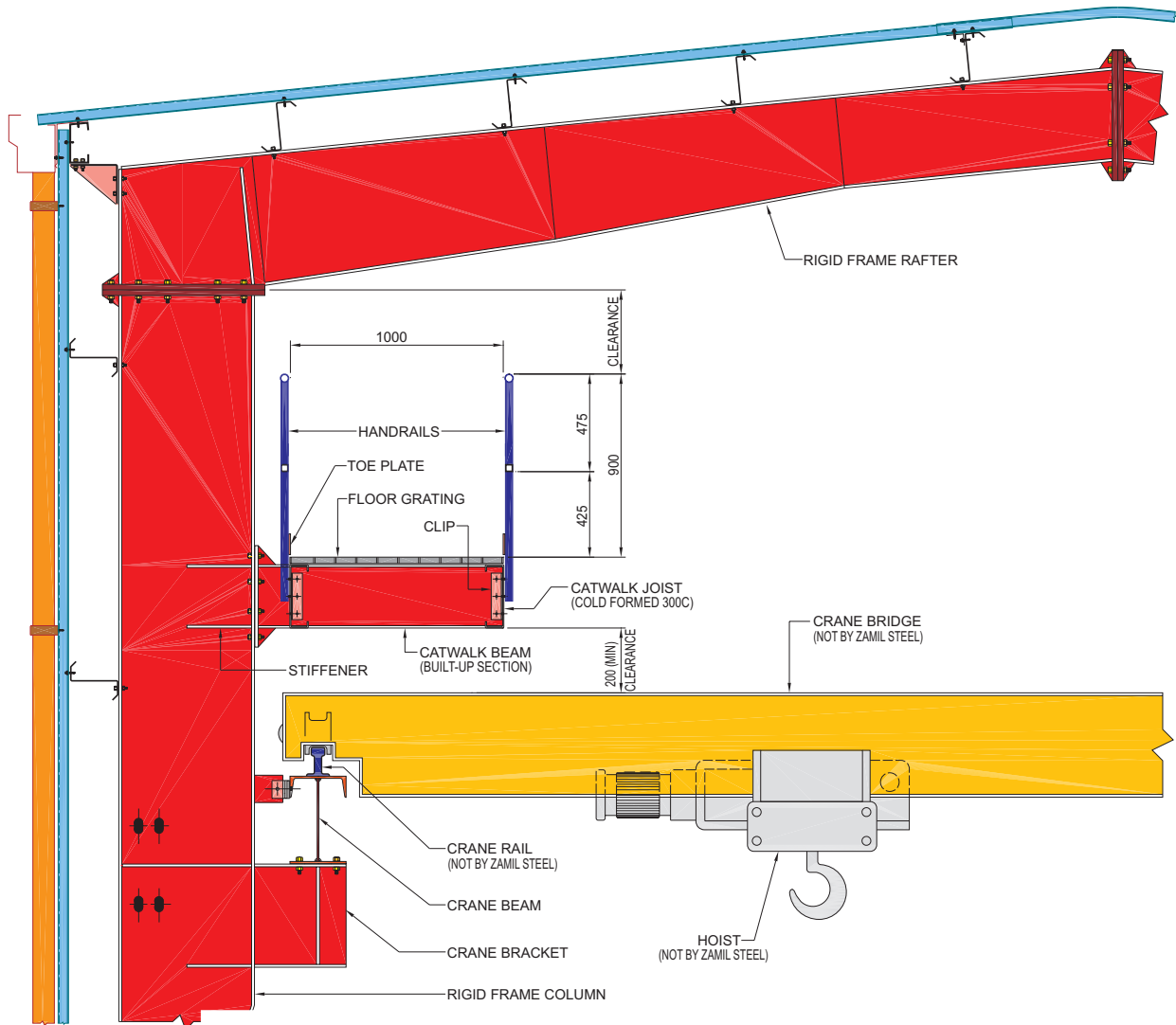

**ELEVATION** : CATWALKS AT RIGID FRAME COLUMN

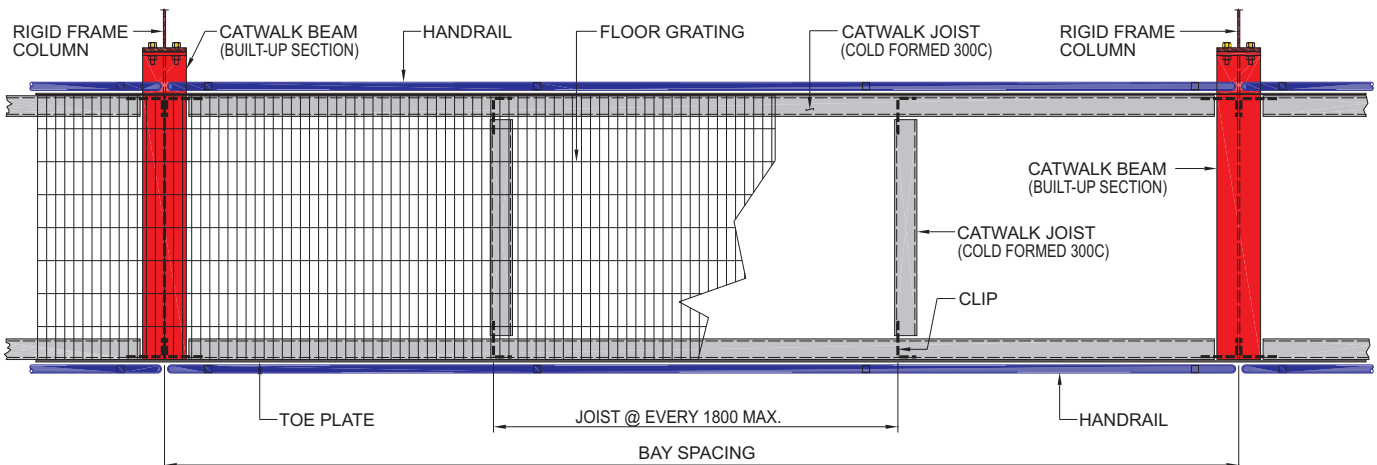

**PLAN** : CATWALKS AT RIGID FRAME COLUMN

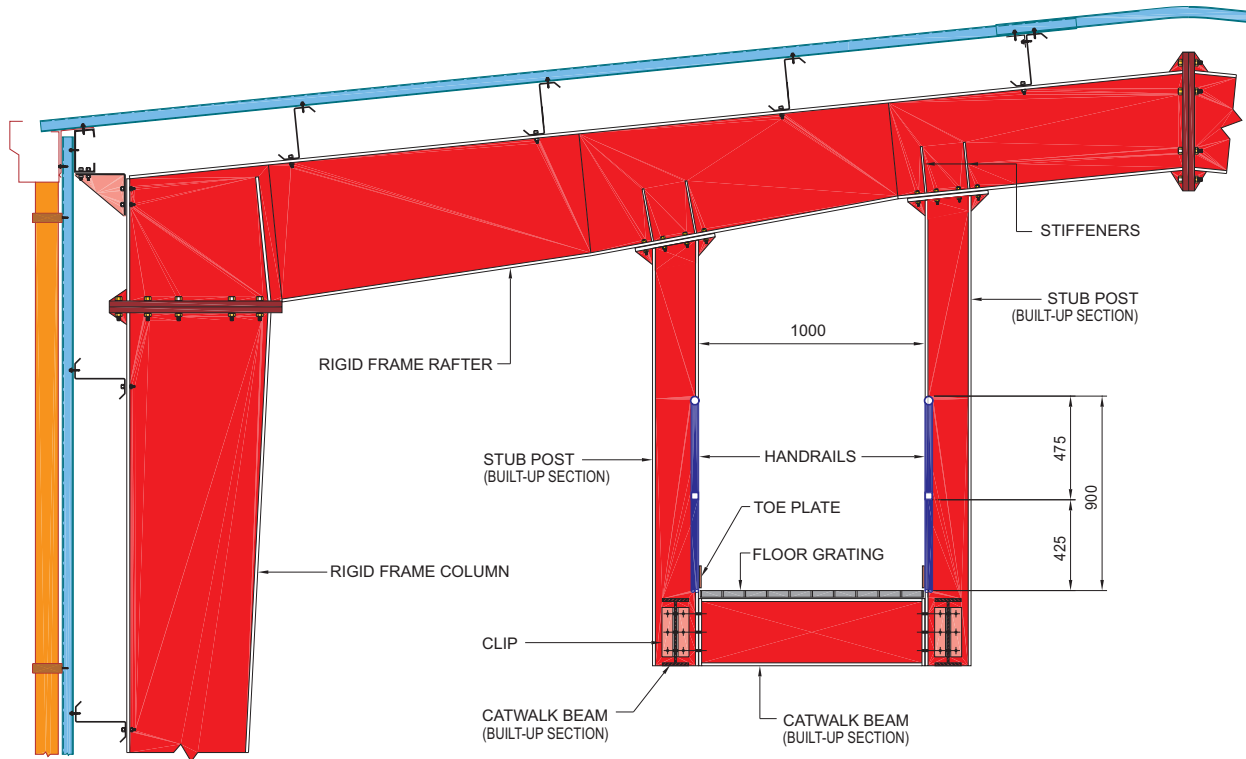

**ELEVATION** : CATWALKS AT RIGID FRAME RAFTER

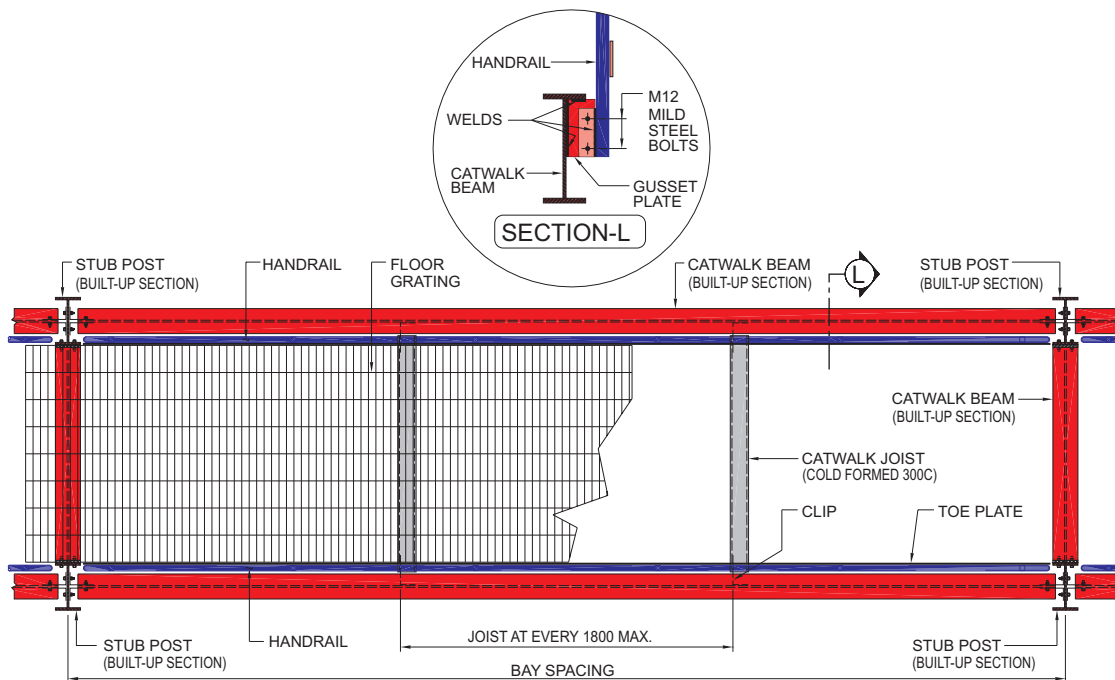

**PLAN** : CATWALKS AT RIGID FRAME RAFTER

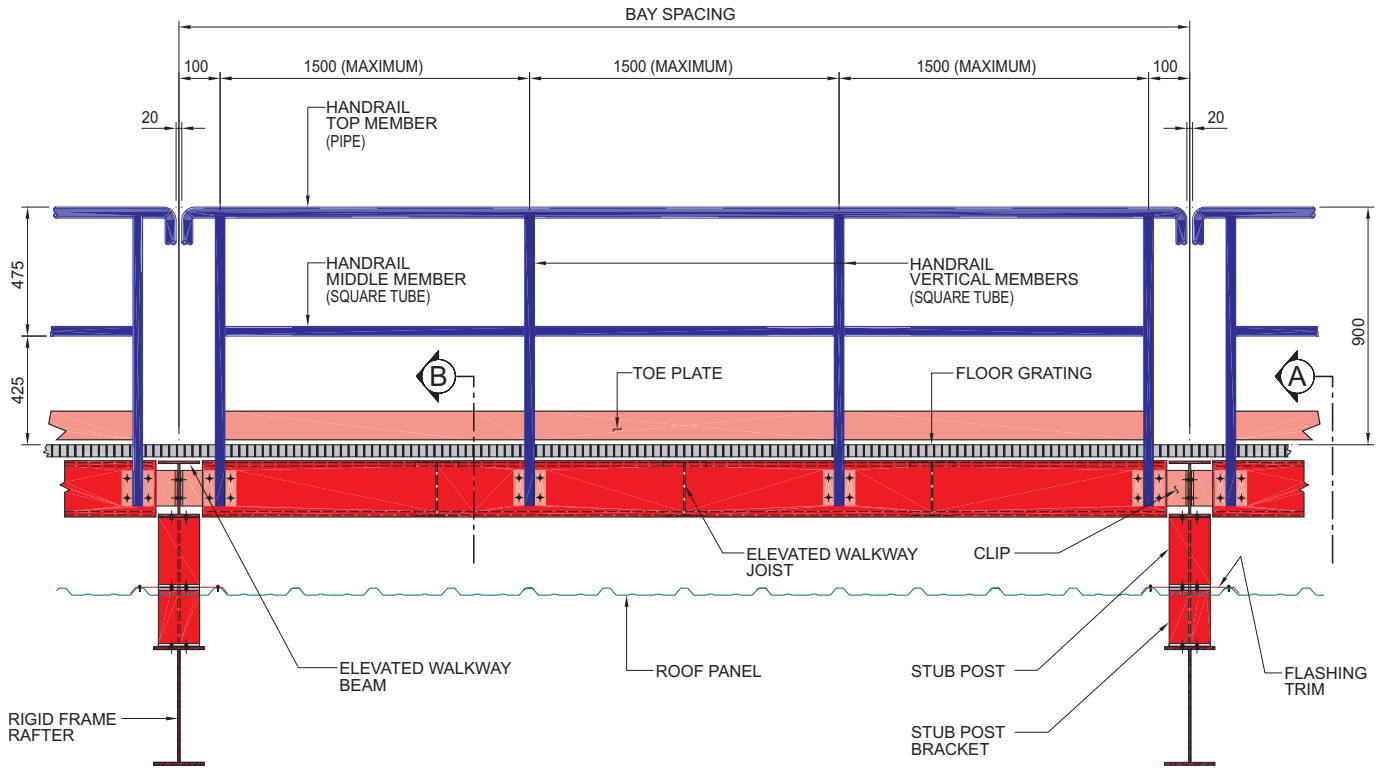

**ELEVATION** : ELEVATED WALKWAY

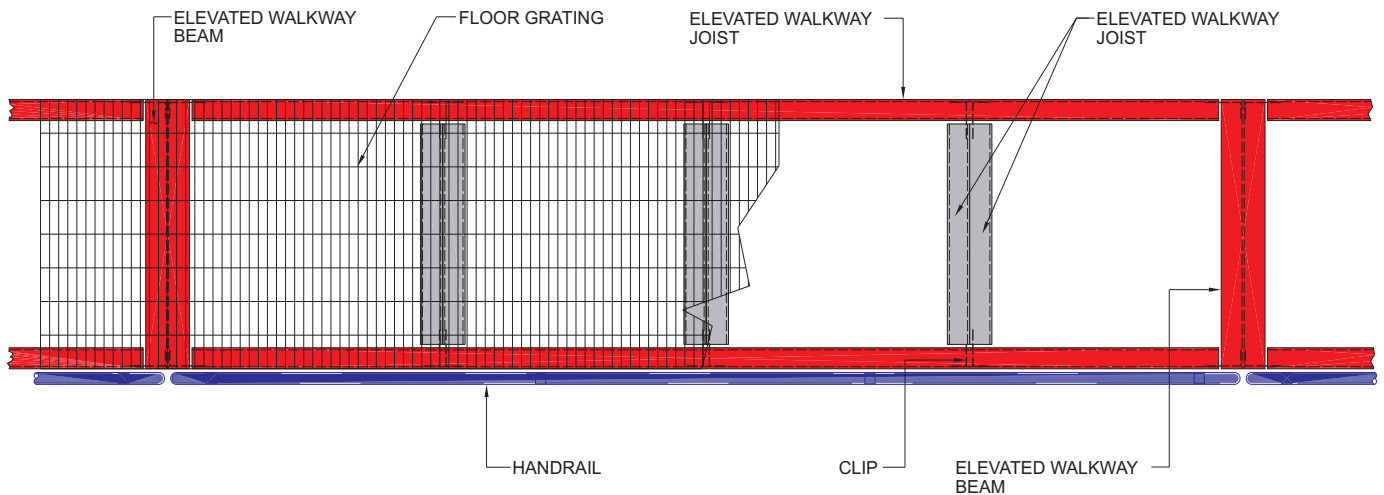

**PLAN** : ELEVATED WALKWAY

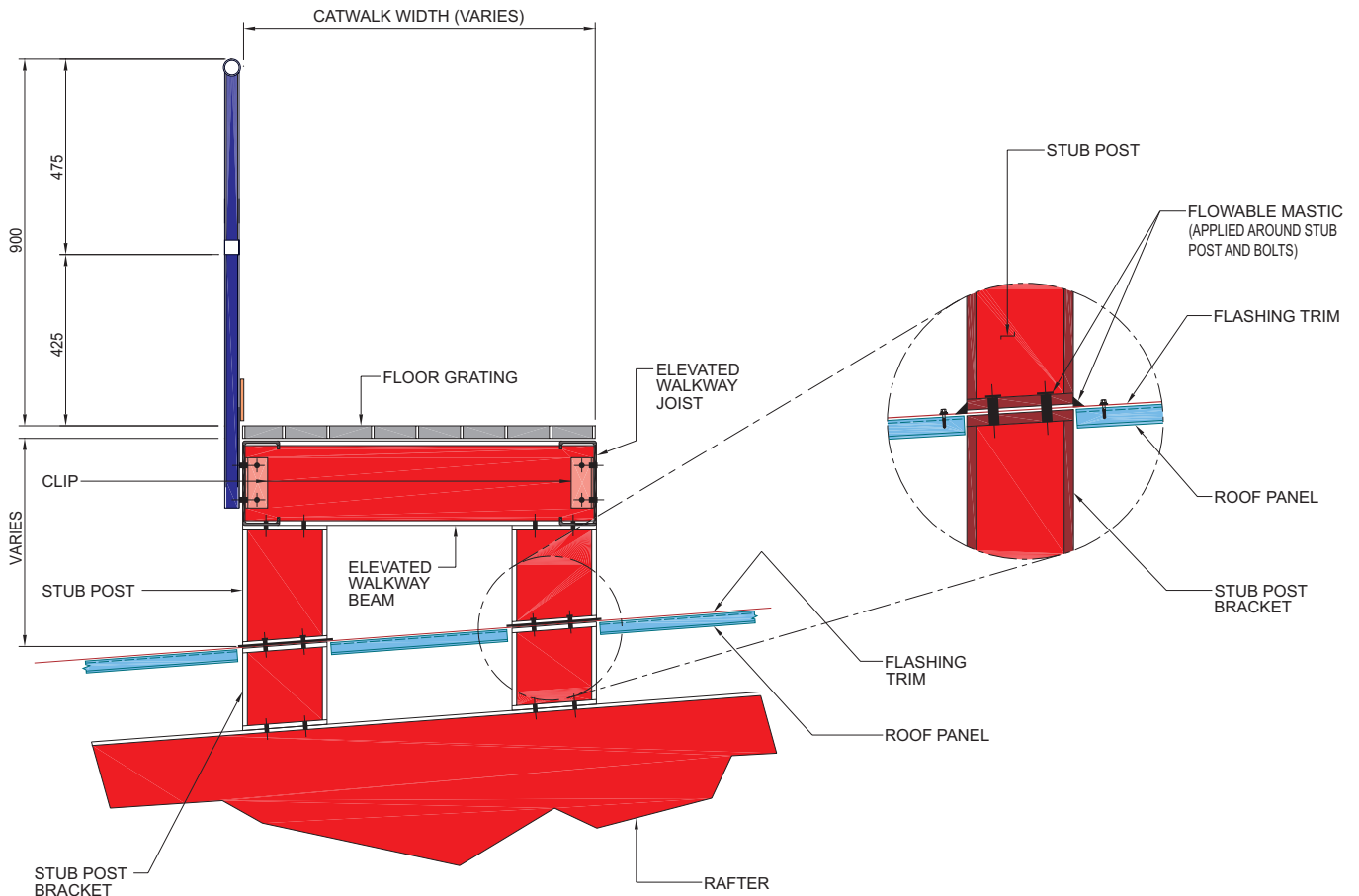

**SECTION-A** : CONNECTION AT ELEVATED WALKWAY BEAM

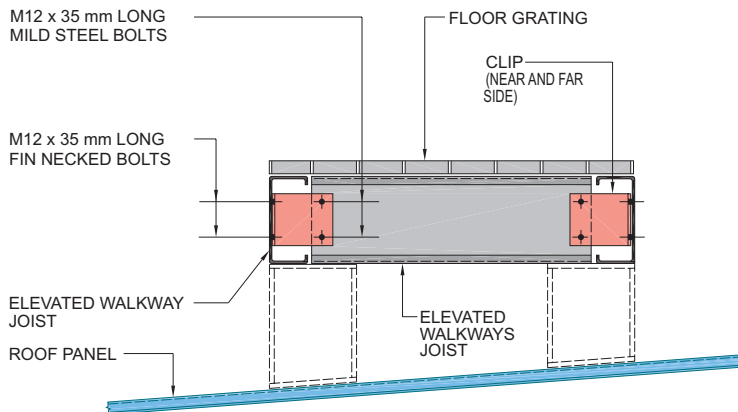

**SECTION-B** : CONNECTION AT ELEVATED WALKWAY JOIST

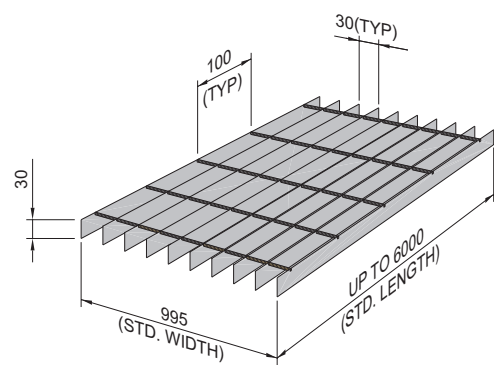

**DETAIL** : STD. FLOOR GRATING DIMENSIONS

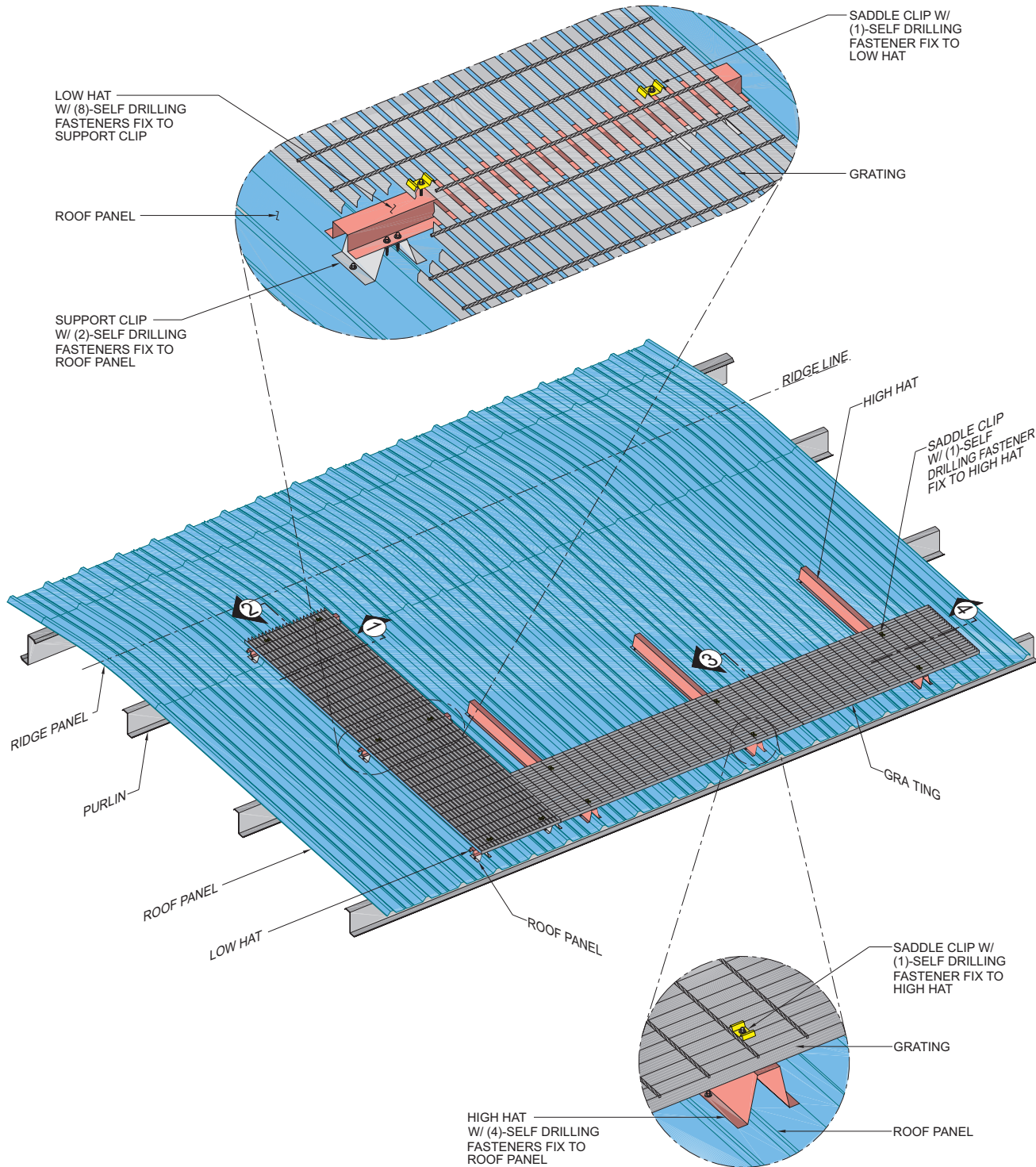

ISOMETRIC : FLUSH WALKWAY

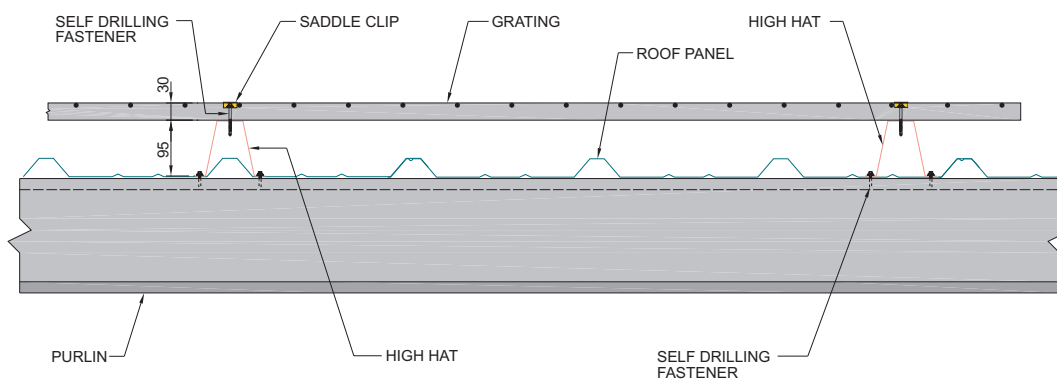
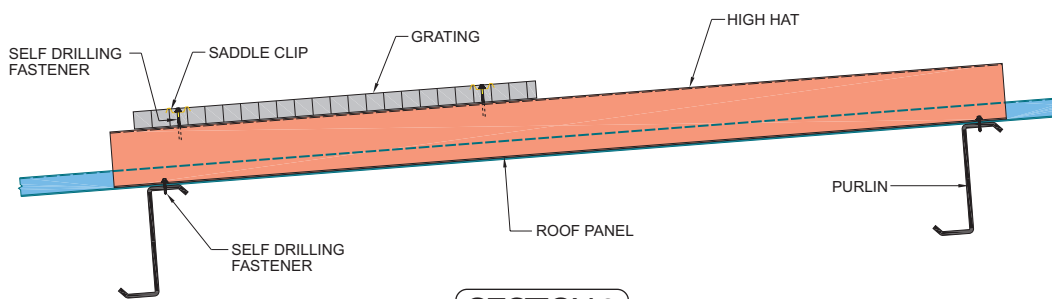
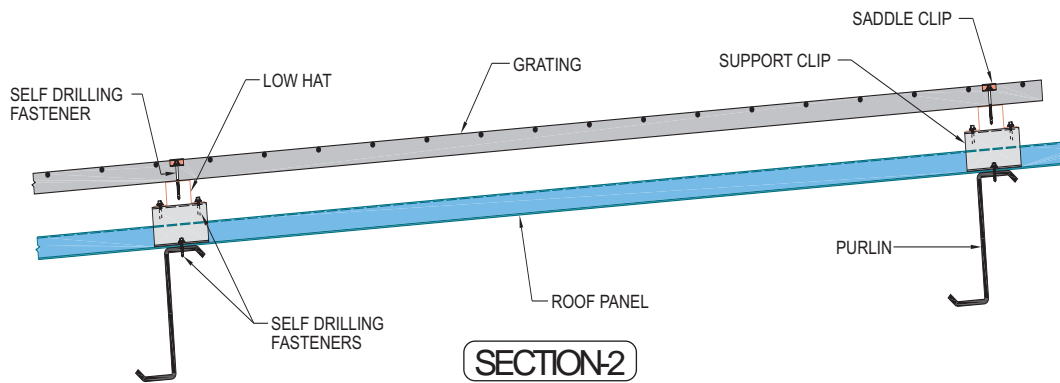
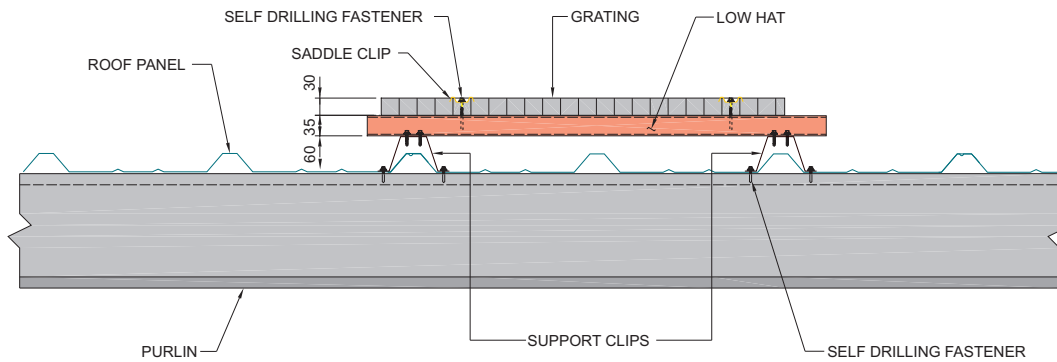

Zamil Steel's standard **staircase** is designed to provide a firm and rigid construction. The stair stringers are detailed in such a way that different stair treads (such as checkered plate, grating or concrete filled treads) can be accommodated or replaced without major modifications.



Zamil Steel standard staircase is a *double flight staircase* with an intermediate or mid-landing. The main structural members are shop assembled to facilitate erection. This leaves only the simple task of connecting the main members of the staircase to the floor framing, attaching the selected type of stair treads and installing Zamil Steel's standard handrail system.

Zamil Steel also offers *single flight staircases* with the following characteristics:

- Single flight staircase with top landing
- Single flight staircase without top landing
- Single flight staircase with top and mid-landing
- Single flight staircase with mid-landing

The paint applied to staircases will match the paint specified for the primary member of the structure.



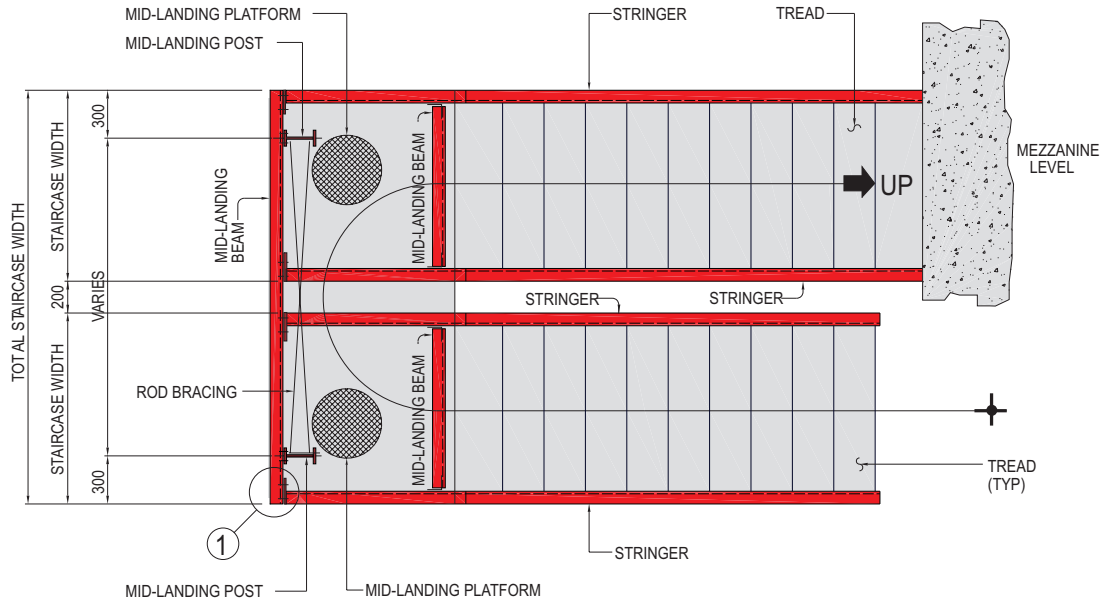

**PLAN** : DOUBLE FLIGHT STAIRCASE

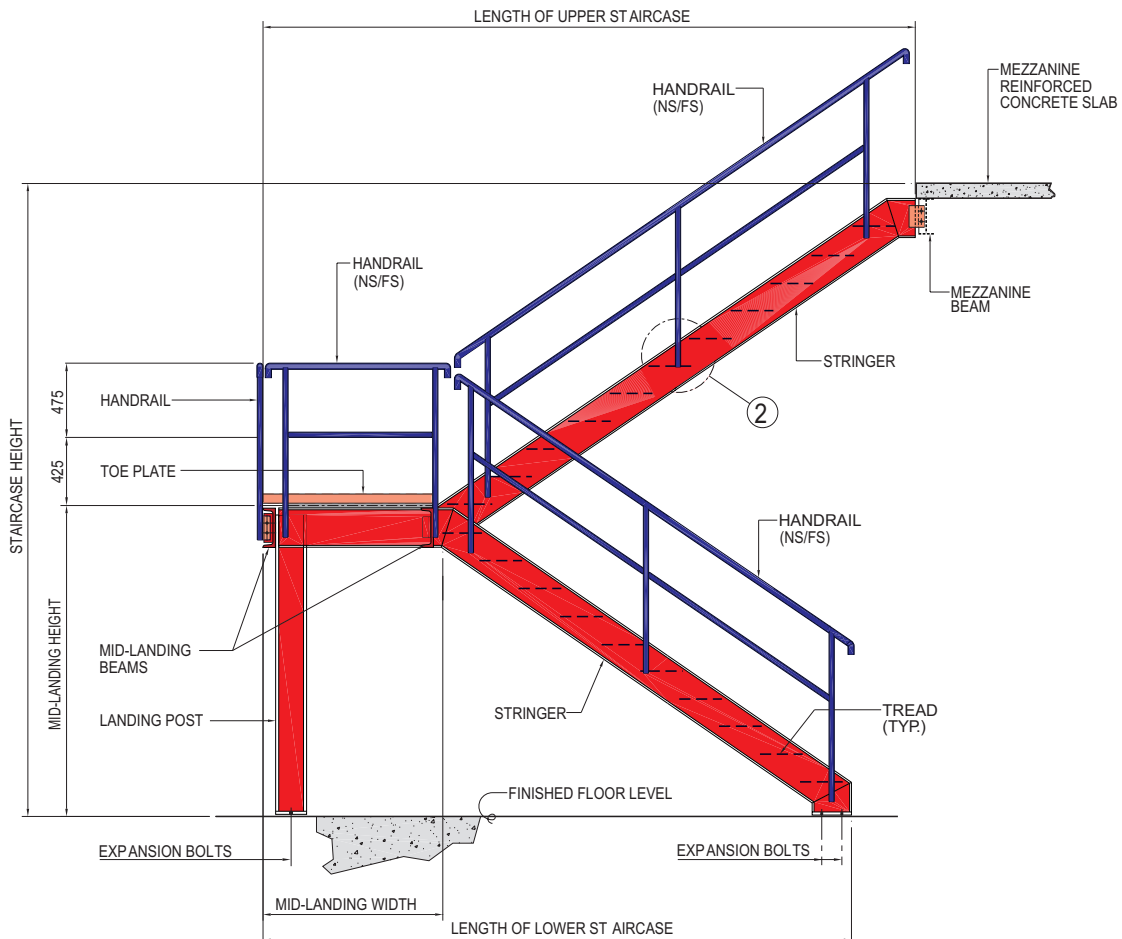

**ELEVATION** : DOUBLE FLIGHT STAIRCASE

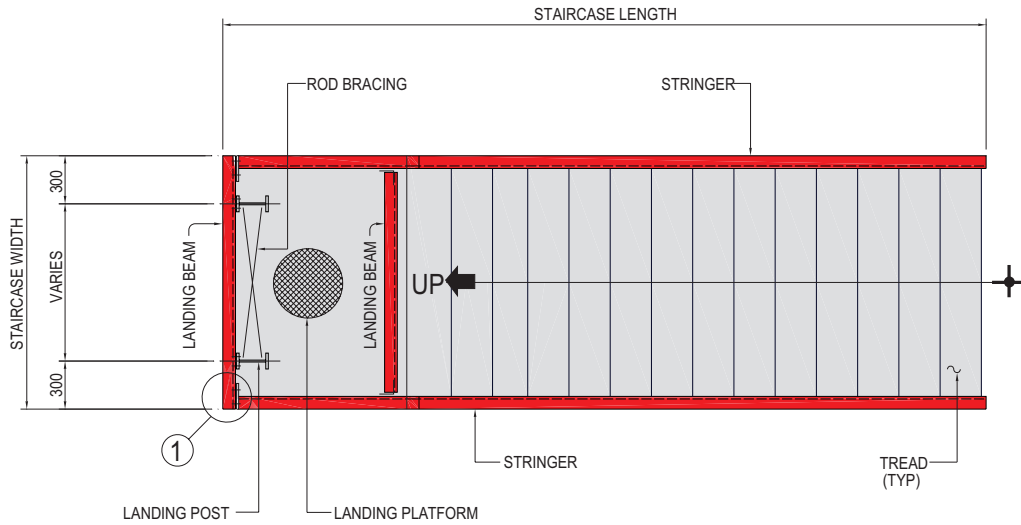

**PLAN** : SINGLE FLIGHT STAIRCASE WITH TOP LANDING

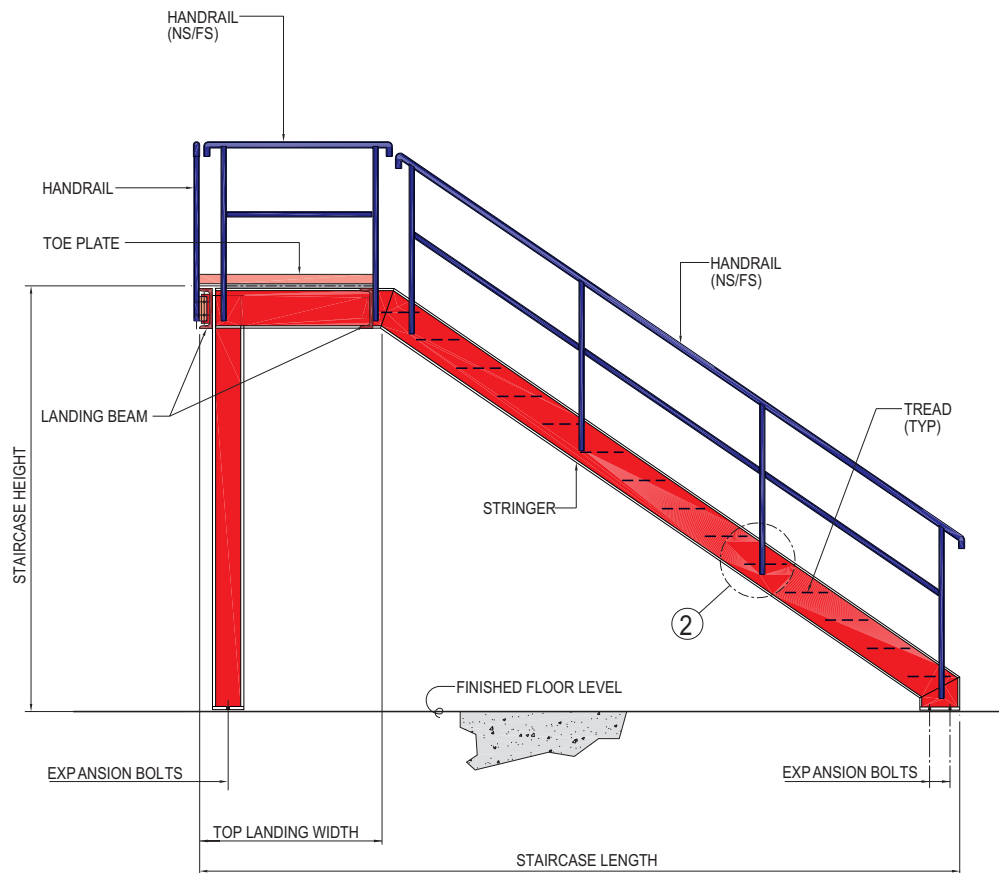

**ELEVATION** : SINGLE FLIGHT STAIRCASE WITH TOP LANDING

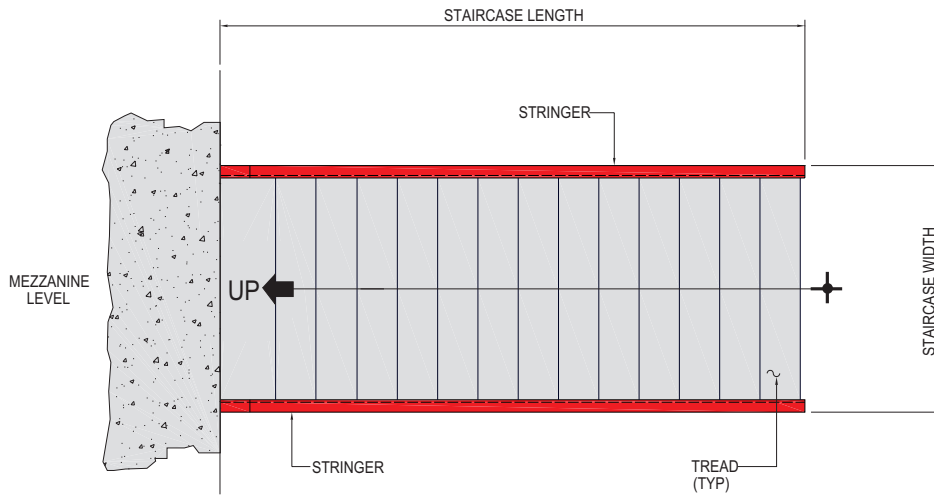

**(PLAN)** : SINGLE FLIGHT STAIRCASE WITHOUT TOP LANDING

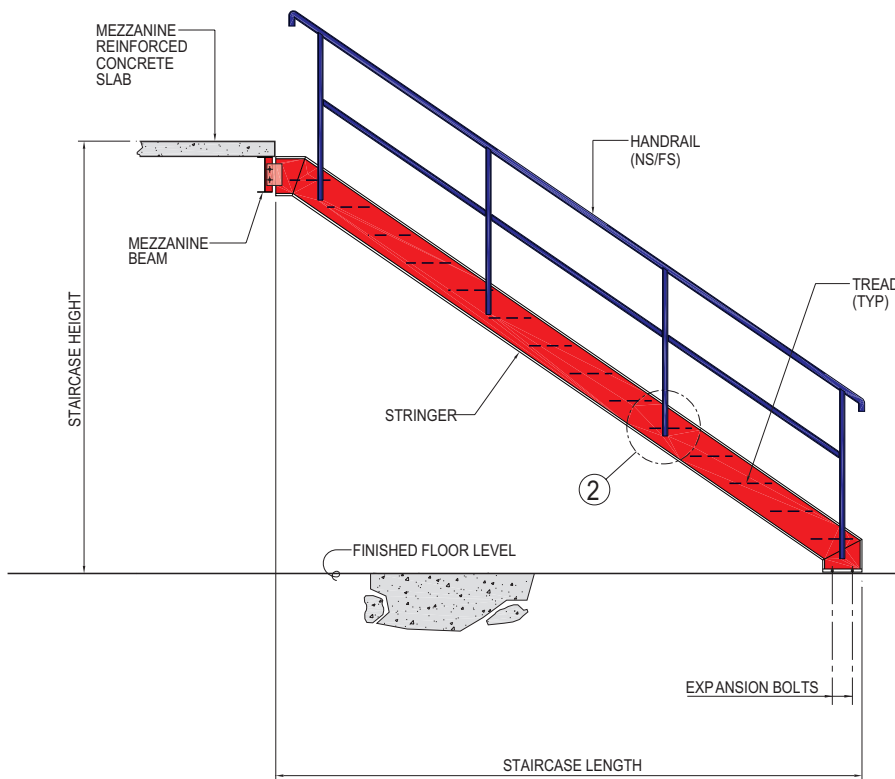

**(ELEVATION)** : SINGLE FLIGHT STAIRCASE WITHOUT TOP LANDING

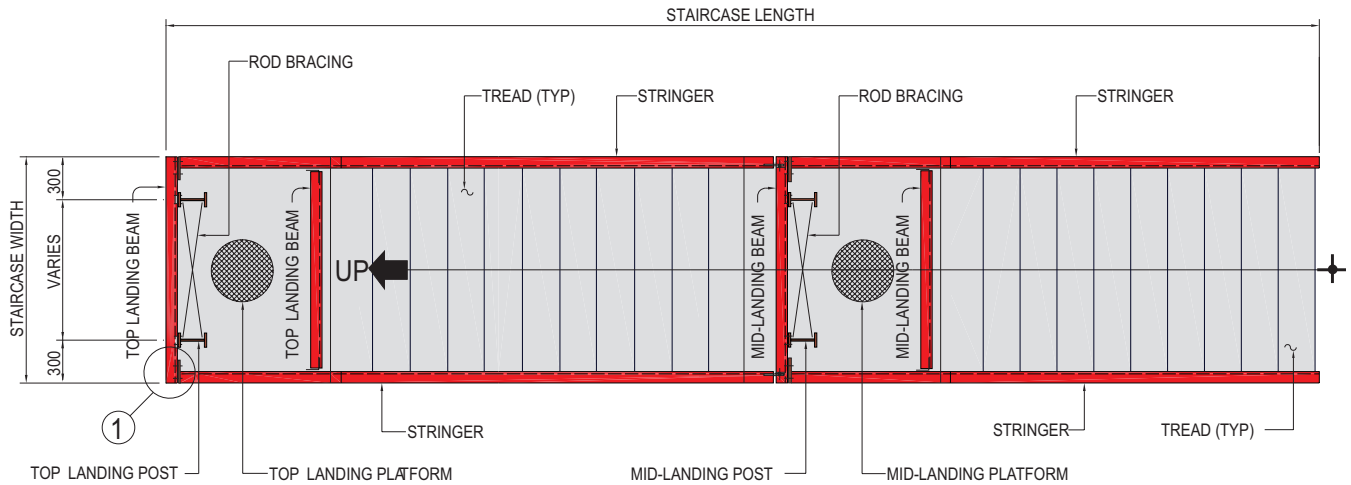

**PLAN** : SINGLE FLIGHT STAIRCASE WITH TOP AND MID-LANDING

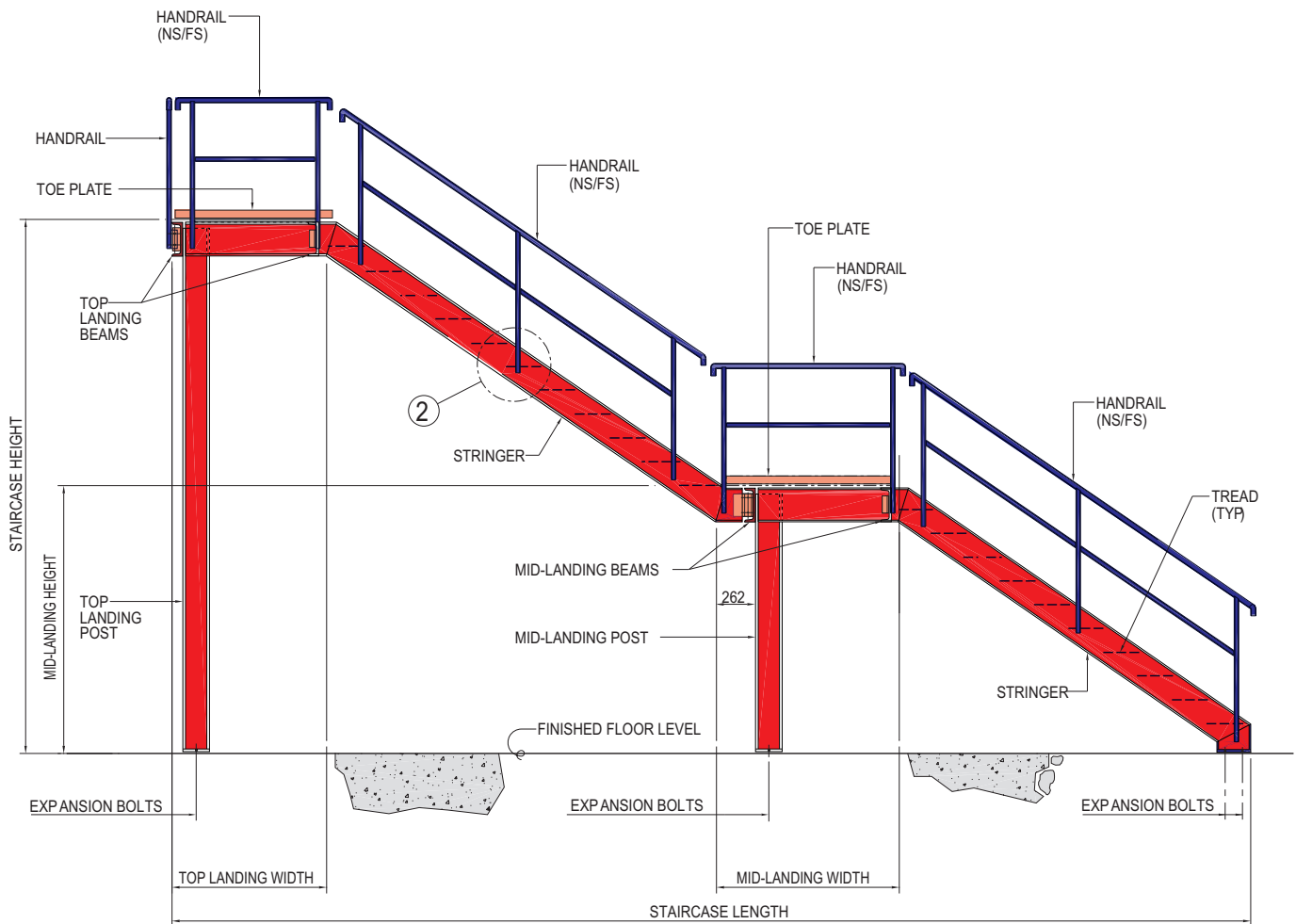

**ELEVATION** : SINGLE FLIGHT STAIRCASE WITH TOP AND MID-LANDING

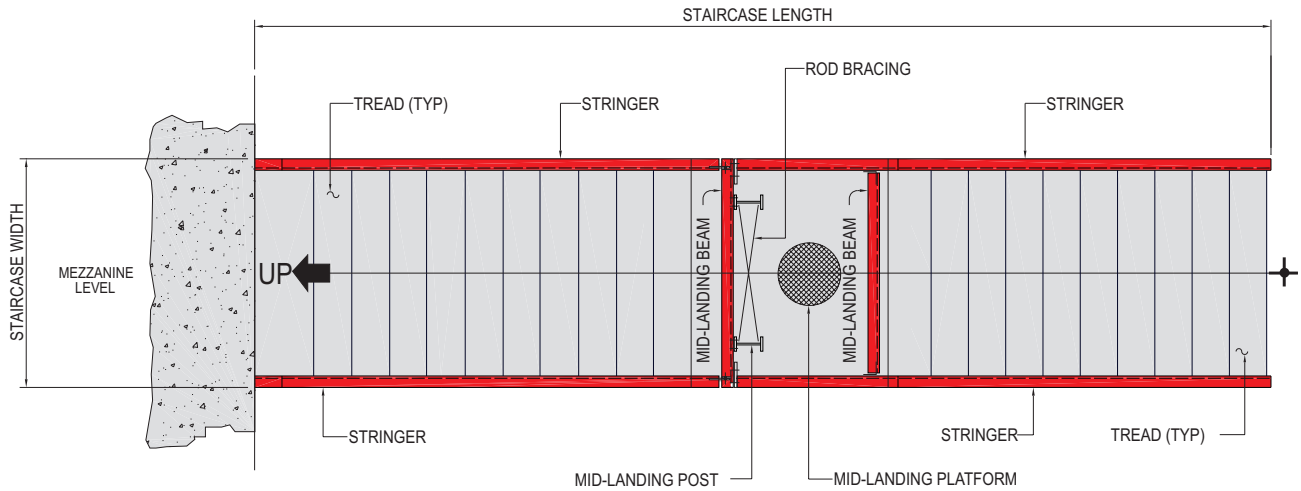

**PLAN** : SINGLE FLIGHT STAIRCASE WITH MID-LANDING ONLY

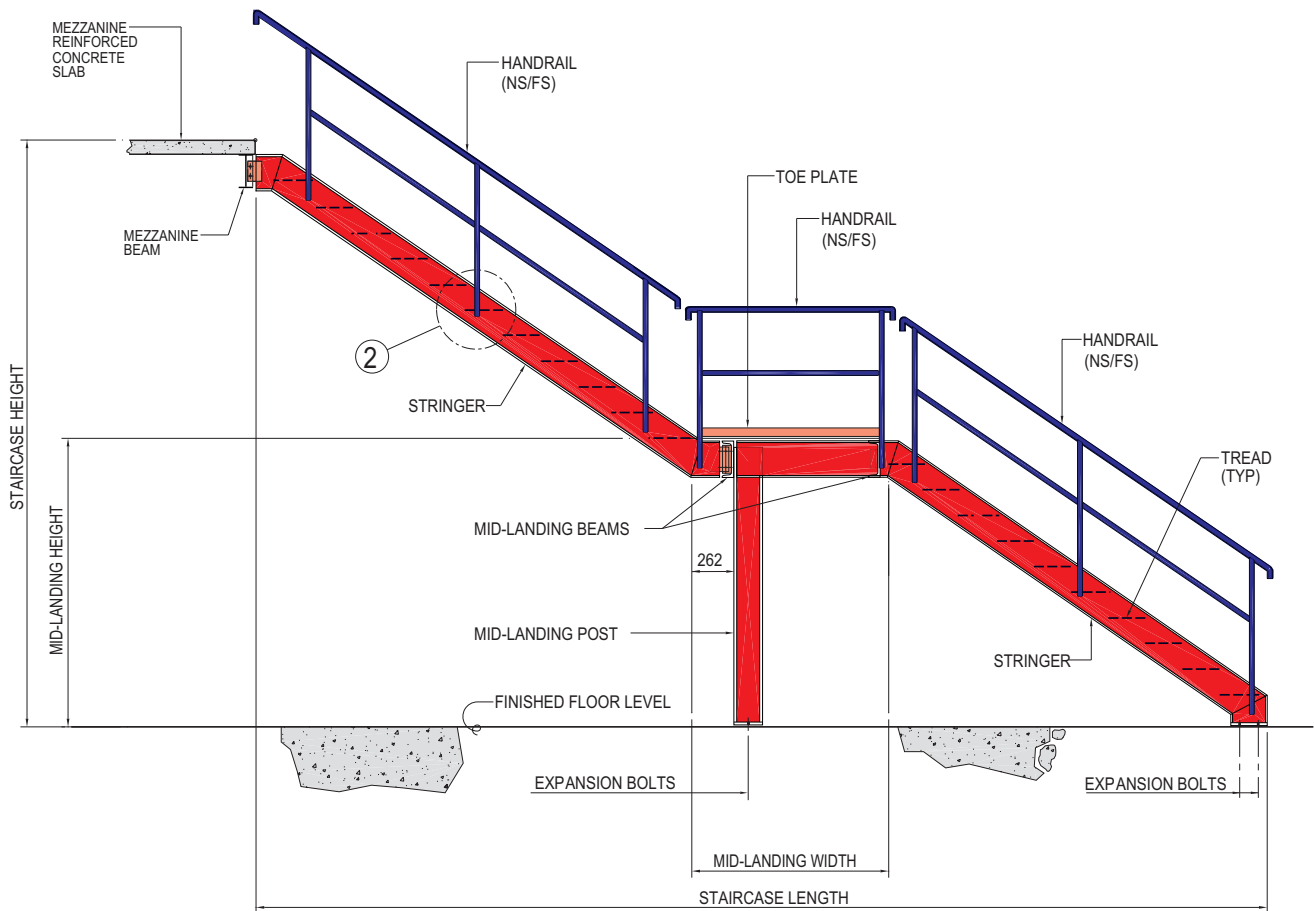

**ELEVATION** : SINGLE FLIGHT STAIRCASE WITH MID-LANDING ONLY

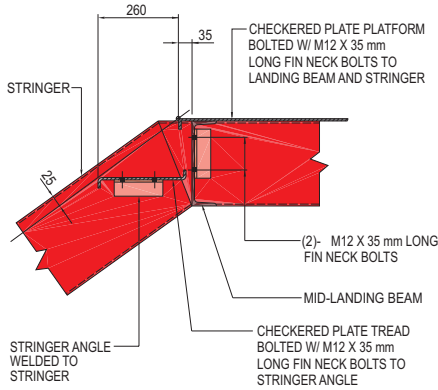

WITH CHECKERED PLATE TREAD

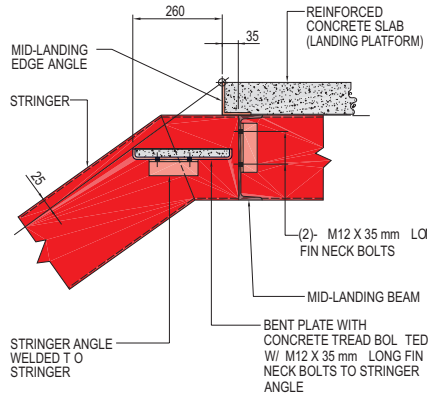

WITH CONCRETE TREAD

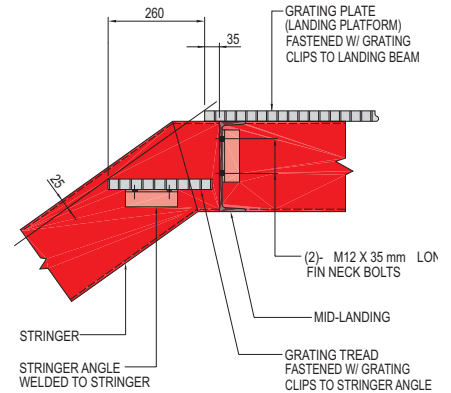

WITH GRATING TREAD

**SECTION :** CONNECTION AT MID-LANDING OR TOP LANDING

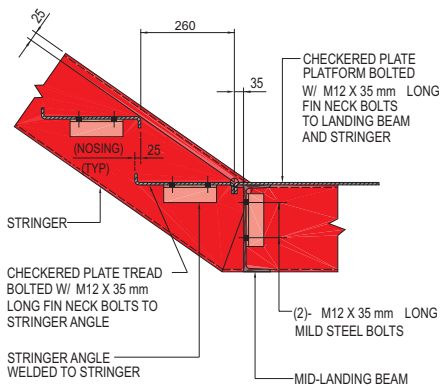

WITH CHECKERED PLATE TREAD

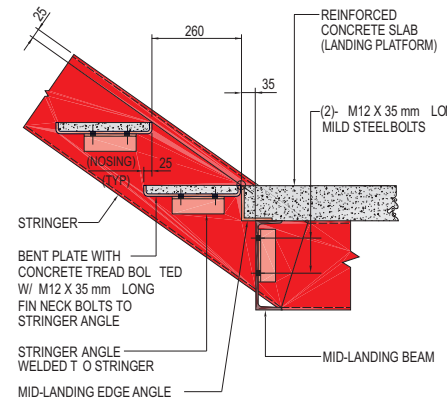

WITH CONCRETE TREAD

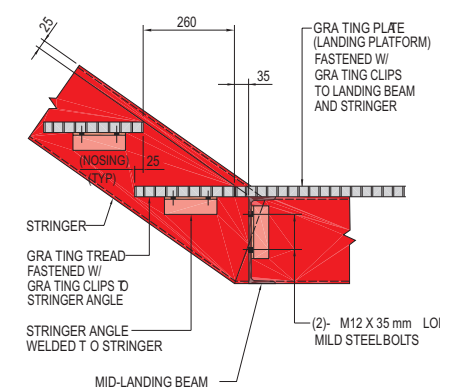

WITH GRATING TREAD

**SECTION :** CONNECTION AT MID-LANDING (DOUBLE FLIGHT STAIRCASE)

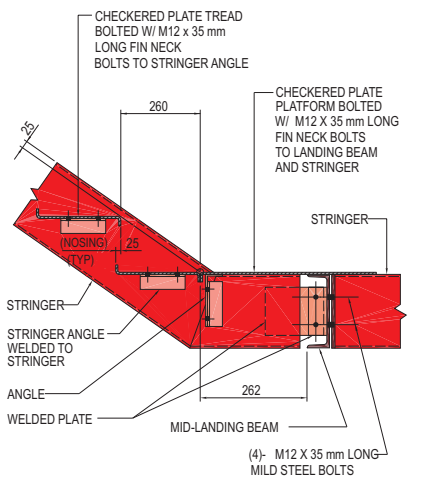

WITH CHECKERED PLATE TREAD

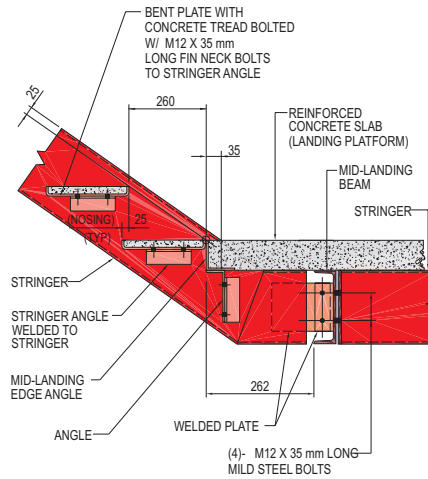

WITH CONCRETE TREAD

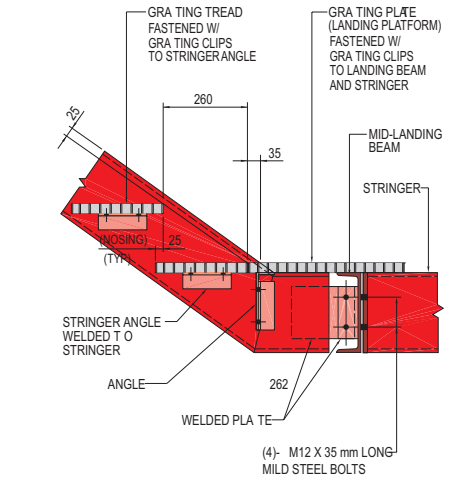

WITH GRATING TREAD

**SECTION :** CONNECTION AT MID-LANDING (SINGLE FLIGHT STAIRCASE)

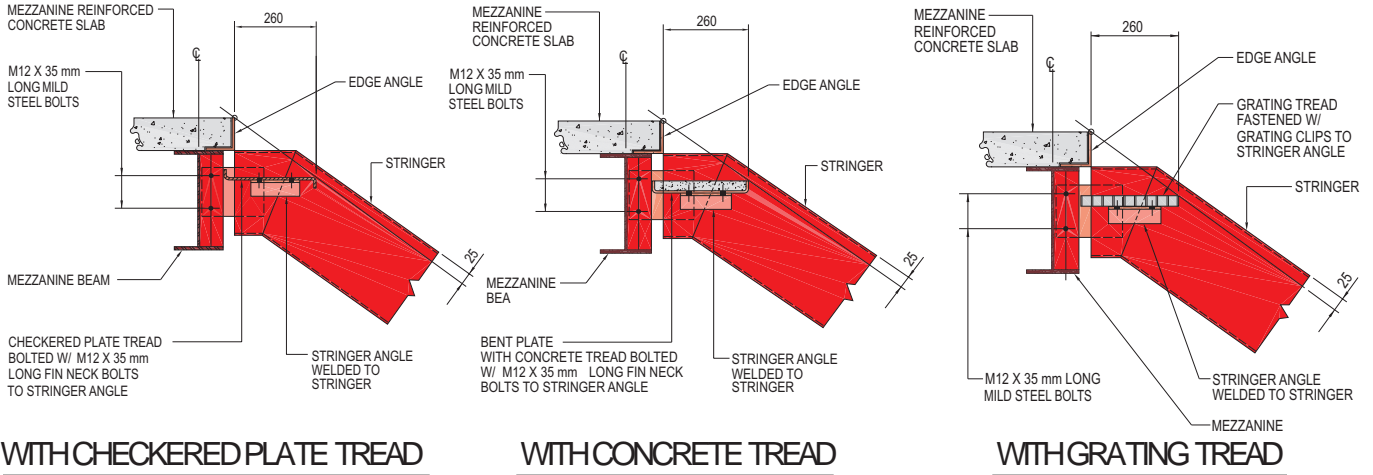

**SECTION** : CONNECTION AT MEZZANINE LEVEL

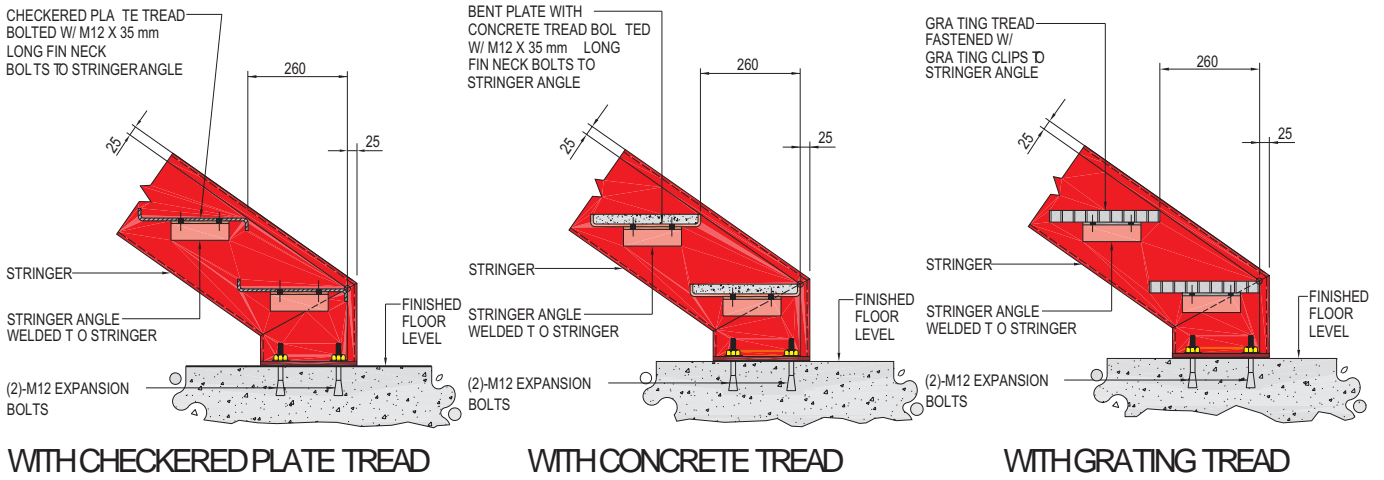

**SECTION** : CONNECTION AT STRINGER BASE

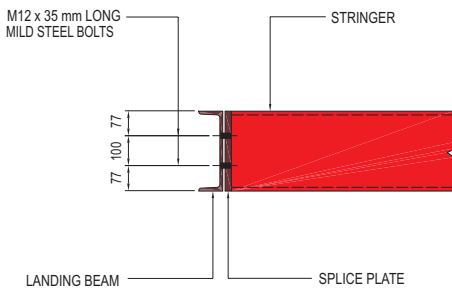

**DETAIL-1** : LANDING BEAM TO STRINGER CONNECTION

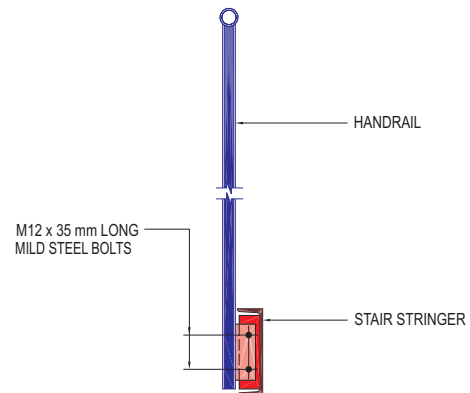

**DETAIL-2** : HANDRAIL TO STRINGER CONNECTION

Zamil Steel offers two types of **handrails**: (1) industrial handrails for platforms, catwalks, walkways and staircases in factories, warehouses, workshops, etc., and (2) office handrails for staircases and mezzanines in office buildings, showrooms, etc.

Handrails may be designed as permanently *fixed* to the substructure (platforms, catwalks, walkways or staircases), or *removable*. They are shipped either with one coat of primer paint or in galvanized finish depending on the customer requirements.

The provision of industrial handrails in platforms, catwalks, walkways and staircases is a safety measure that is highly recommended. The initial cost of handrails is more than justified by the safety that they represent. It is Zamil Steel's policy to create products that are safe and reliable and to always advise the customers to design their buildings to meet the maximum requirements of prevailing safety standards. Therefore, it is strongly recommended that handrails be specified when ordering platforms, catwalks and staircases.

Industrial handrails are fabricated from 48 mm diameter pipes that are used as top rails, and from 40 x 40 x 2 mm thick square tubes that are used for the mid-rail and for the posts of the handrail.

Office handrails are fabricated from 38.1 mm or 50.8 mm diameter tubes which are welded to ball connectors.

For both types a 100 mm wide x 6 mm thick kicker or toe plate is welded at the base of the handrail posts to complete the whole assembly. The height of the post is 900 mm measured from the top of the flooring to the top face of the top rail.





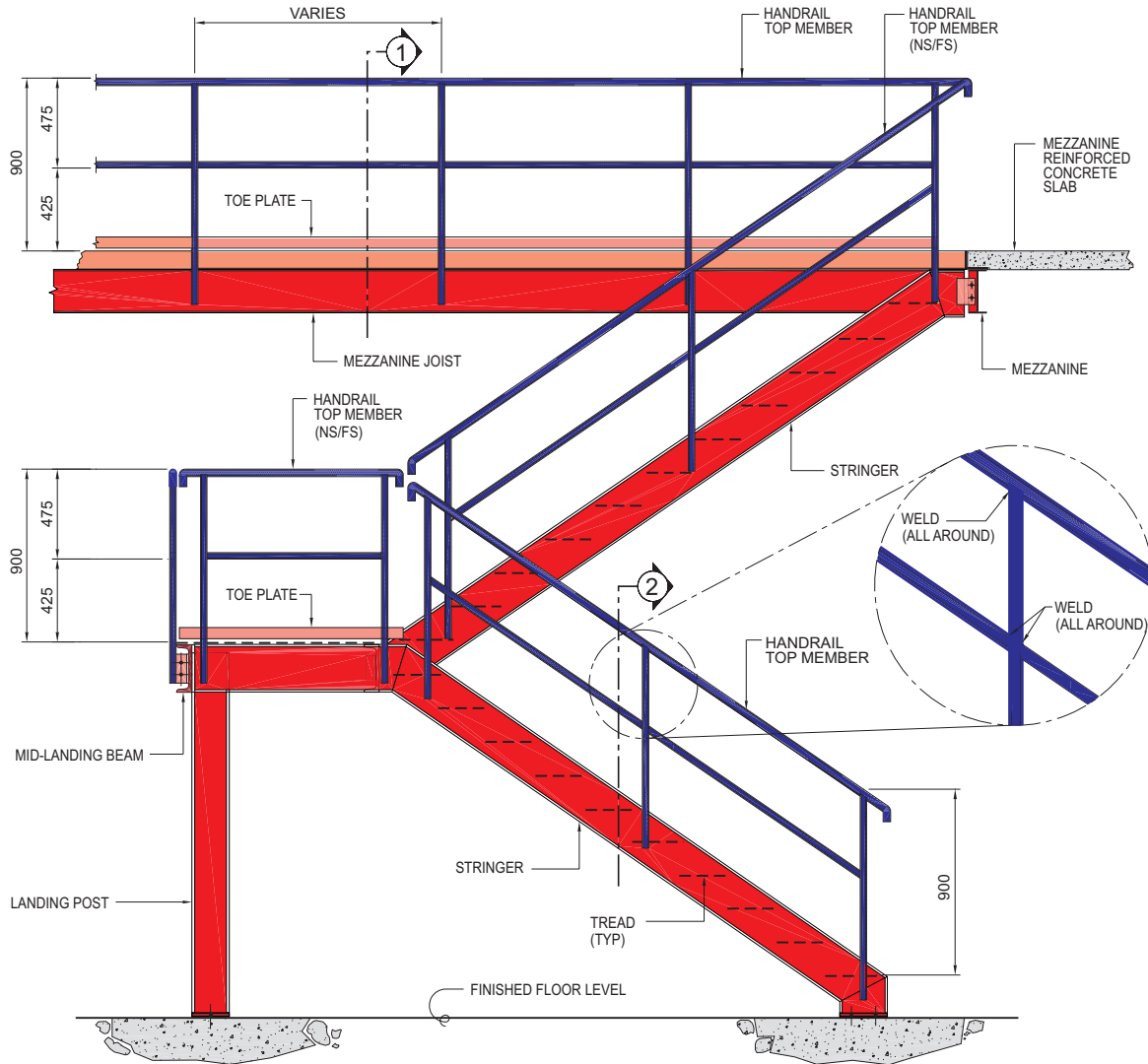

**ELEVATION** : TYPICAL INDUSTRIAL HANDRAILS

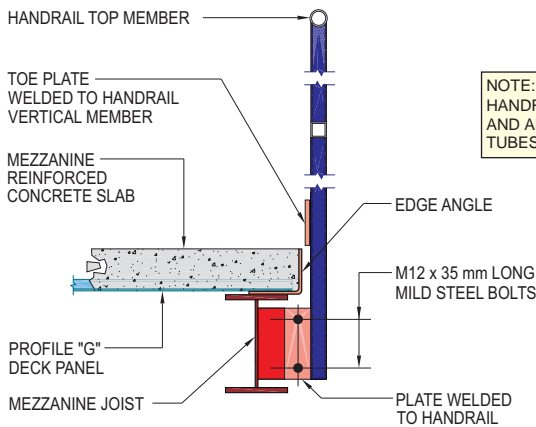

**SECTION-1**

NOTE:  
HANDRAIL TOP MEMBER IS A 48mm Ø PIPE  
AND ALL OTHER MEMBERS ARE SQUARE  
TUBES (40 x 40 x 2mm).

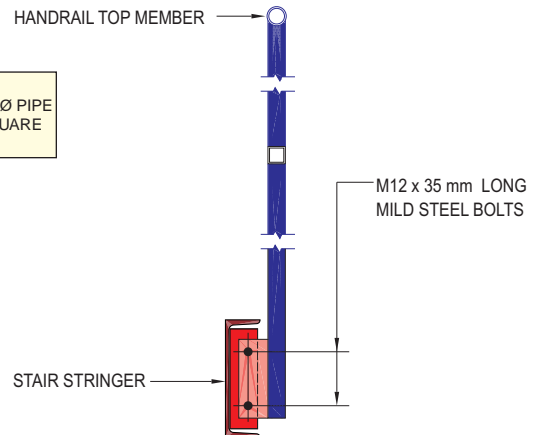

**SECTION-2**

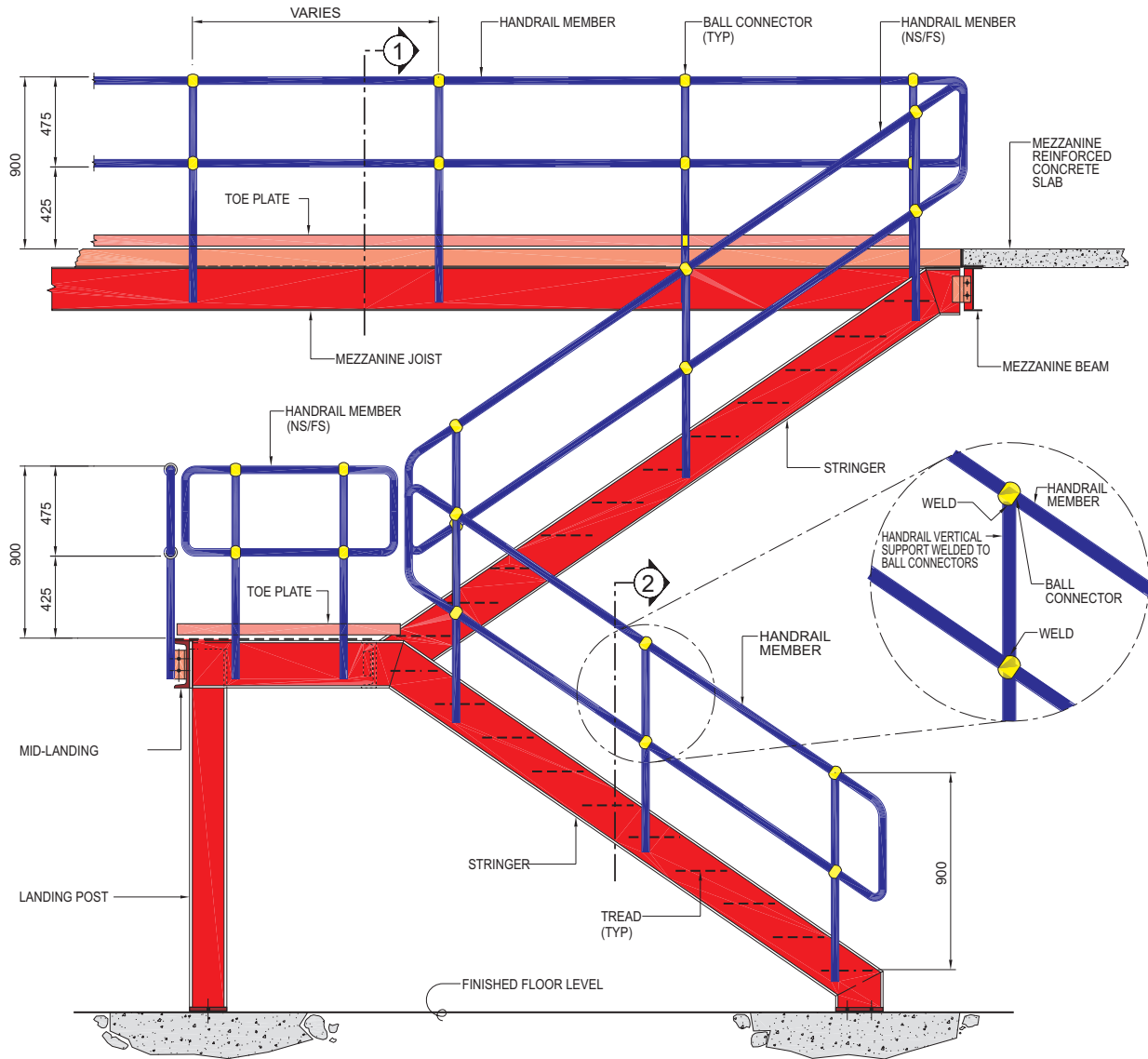

**(ELEVATION) : TYPICAL OFFICE HANDRAILS**

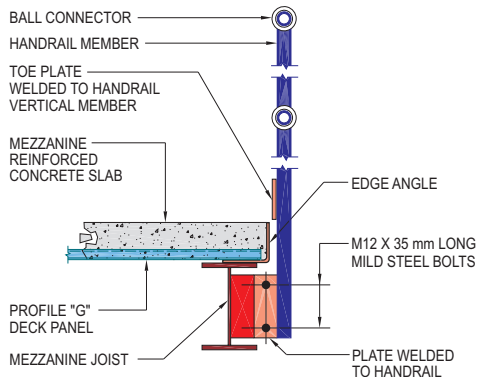

**SECTION-1**

NOTE:  
HANDRAIL MEMBER CAN EITHER BE OF THE FOLLOWING: FOR HEAVY USE = 50.8mm OUTSIDE DIAMETER TUBE FOR LIGHT/MEDIUM USE = 38.1mm OUTSIDE DIAMETER TUBE

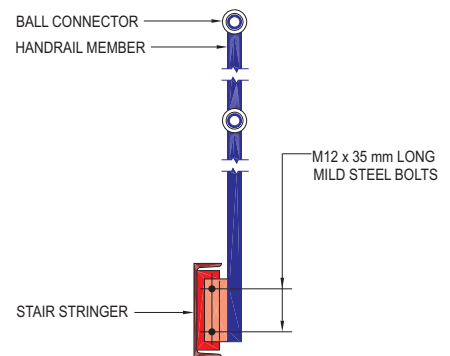

**SECTION-2**

Zamil Steel standard **ladders** are made of vertical members (rails) that are shopfabricated from hot rolled angles, channels or flat bars, and rungs that are made from round bars.

Ladders are fixed to the secondary members of the walls and roof by clips and fasteners for easy and quick installation.

Ladders are available in two types: *plain ladders* and *caged ladders*.

- Plain ladders are used when the ladder height is not more than 3 m.
- Caged ladders are used when the elevation, to be reached, is more than 3 m. Flat bar rings welded to the ladder rails provide safety as well as strength and rigidity to the ladder.

Zamil Steel ladders are supplied in either red oxide or galvanized finish and are shipped in semi knocked-down packages for easy handling and easy assembly at the jobsite.

Ladders are convenient and economical tools for accessing roofs. It is highly recommended that a building contains at least one ladder to provide a safe access to the roof for maintenance purposes.



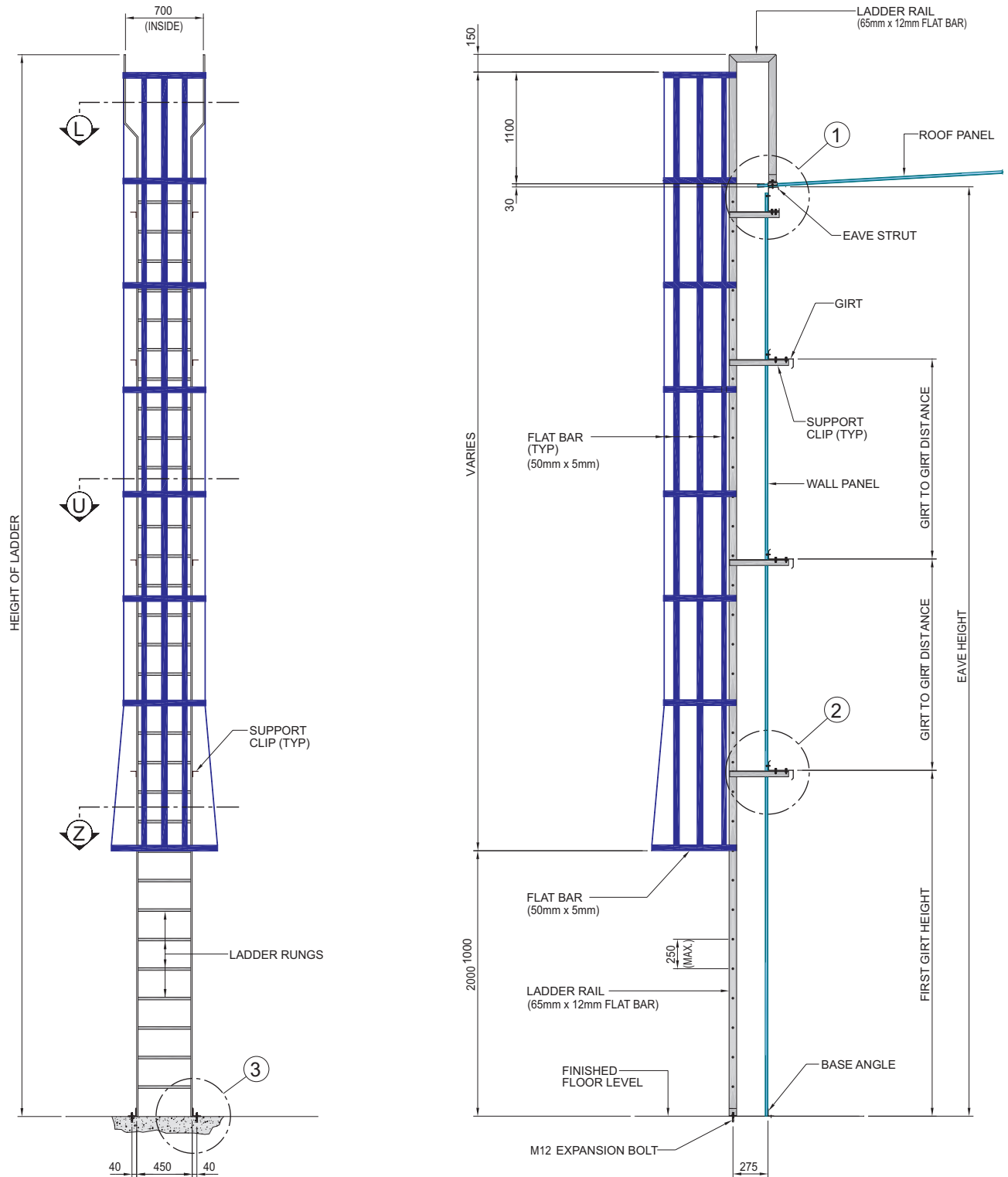

**ELEVATION** : TYPICAL LADDER ASSEMBLY

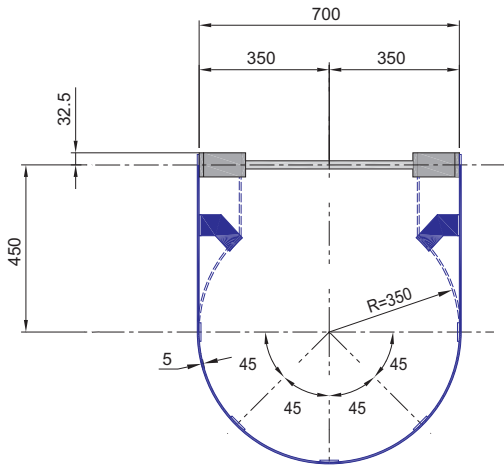

SECTION-L

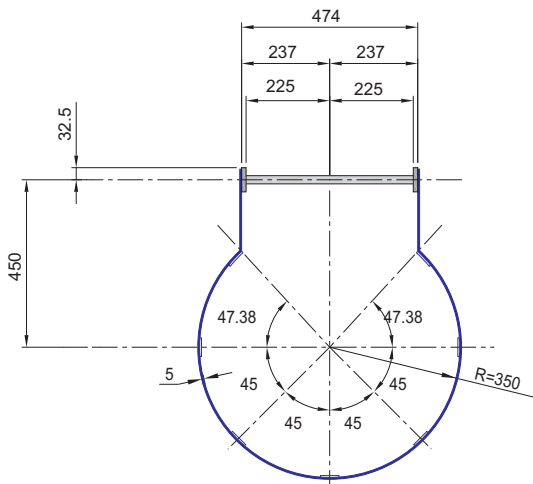

SECTION-U

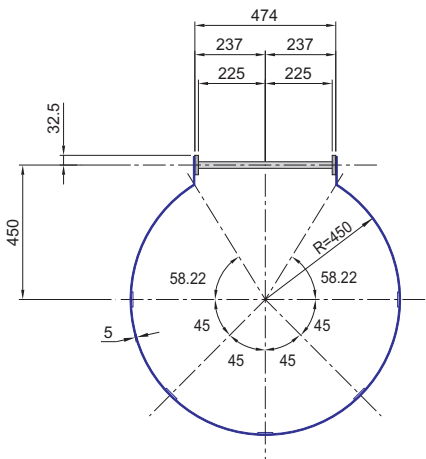

SECTION-Z

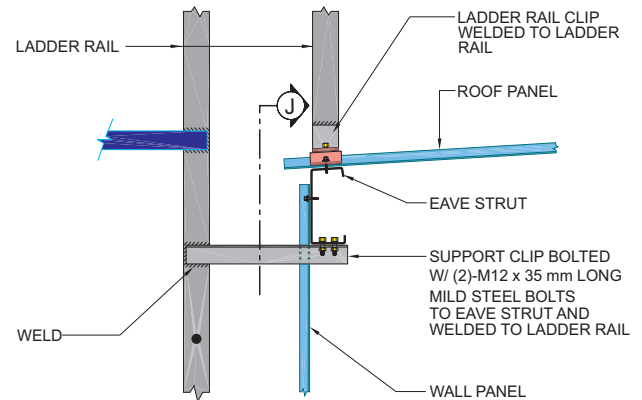

DETAIL-1

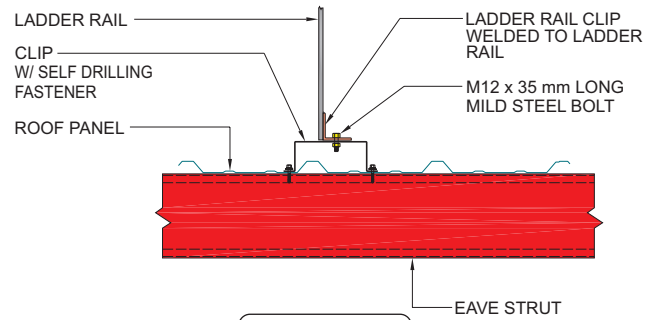

SECTION-J

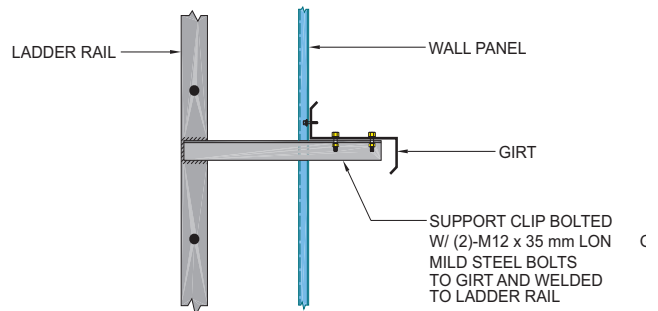

DETAIL-2

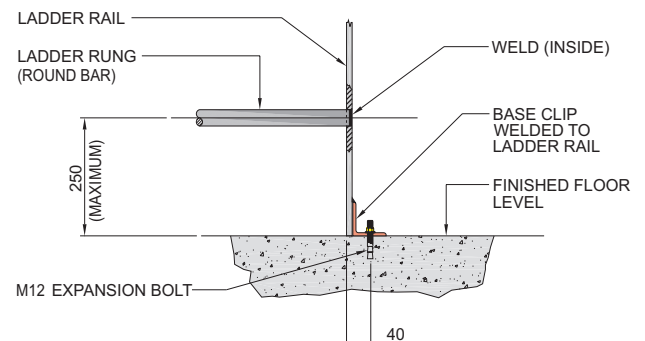

DETAIL-3

Zamil Steel offers galvanized **grating** plates as a standard option to be used in the floorings of interior and exterior catwalks and roof platforms. They can also be used, in lieu of concrete and checkered plates, for mezzanine floors, stair treads and stair landings.

Grating floors are normally used in factories, warehouses, and workshops in which the mezzanines are used for material storage, equipment monitoring, material handling, etc., and where the more common, but costlier, concrete floor finish is not required.

The main distinctions that grating has over checkered plates (see **section 12.10**), both of which can be used interchangeably, are that grating is

galvanized, thus making it more suitable for external uses; does not retain water, thus eliminates the need for a drainage system; and does not allow the accumulation of dirt and dust on its surface, thus reduces cleaning requirements.

Zamil Steel grating plates are constructed from 30 mm x 3 mm rectangular bearing bars that are traversed with 6 mm twisted square bars that are forge welded at 100 mm pitch to form a 30/100 (i.e., 30 x 100 mm) mesh. The steel of grating conforms to EN10025 Grade S275JR, or equivalent.

The standard size of a Zamil Steel supplied grating plate is 995 mm wide x 6000 mm long.

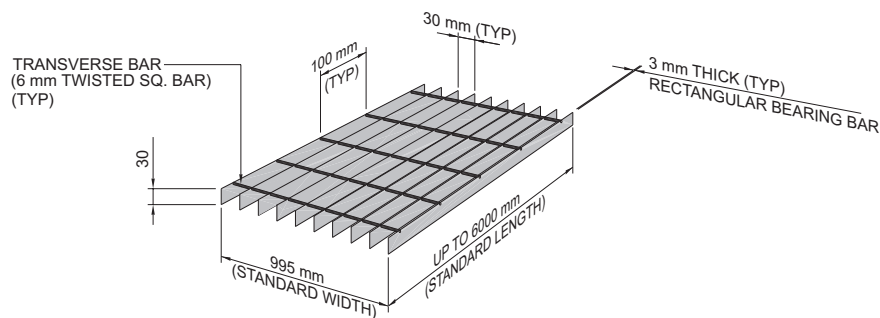

**ELEVATION** : STANDARD GRATING DIMENSIONS

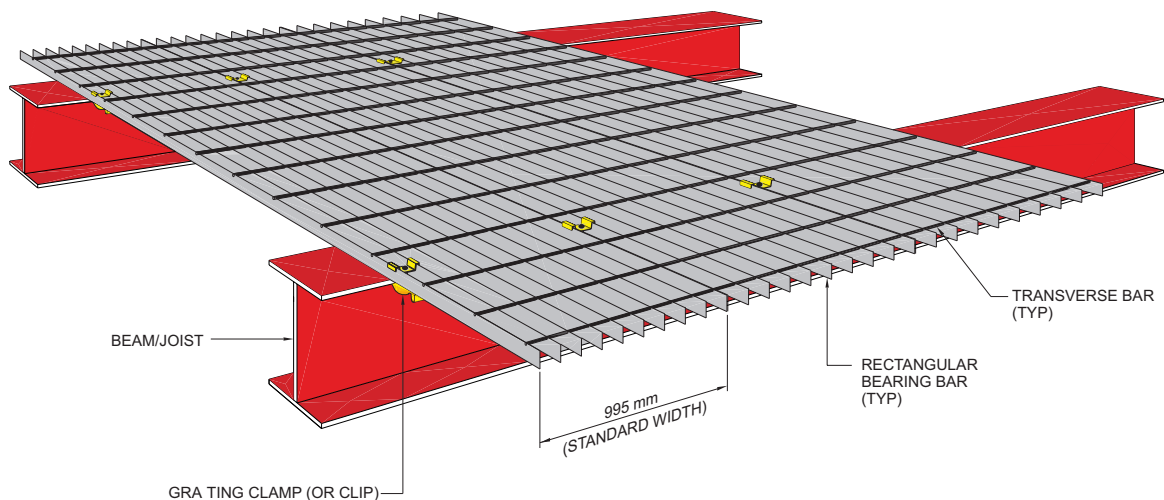

**APPLICATION OF GRATING**

**Checkered plates** are another option that Zamil Steel offers as a flooring system. Both checkered plates and grating are used for the same applications and in the same areas such as floorings of catwalks, walkways, roof platforms, mezzanines, stair treads, and stair landings.

Checkered plates are also used in factories, warehouses, and workshops in which the mezzanines are used for material storage, equipment monitoring, material handling, etc. and where the more common, but costlier, concrete floor finish is not required.

Checkered plates are solid non-slippery plates. They are suitable for floors on which a lot of dust and dirt might be accumulated from material handling, material storage, equipment (oil leaks), etc., that should be prevented from dropping (or dripping) underneath.

Zamil Steel checkered plates have a tear drop pattern and are made of ASTM A36 black steel, or equivalent.

The standard size of a Zamil Steel supplied checkered plate is 2000 mm wide x 6000 mm long x 5 mm (nominal) thick.

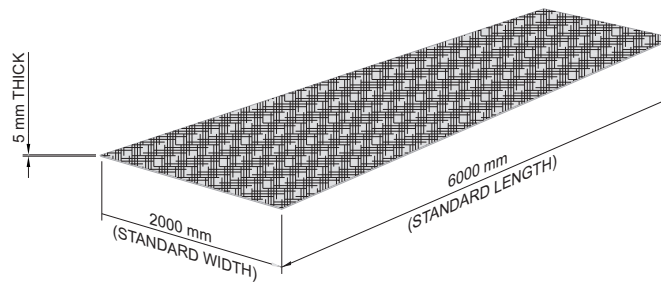

**ELEVATION** : STANDARD CHECKERED PLATE DIMENSIONS

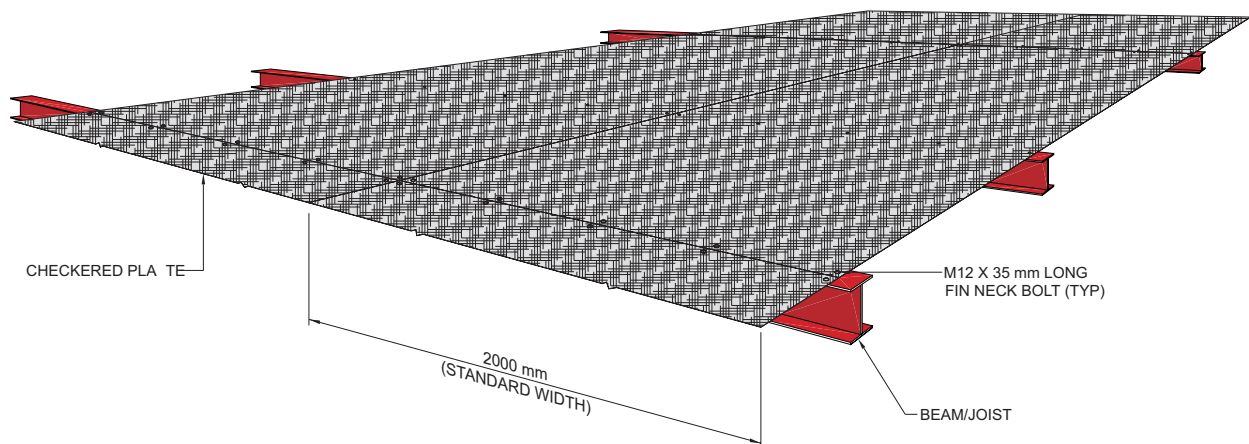

**APPLICATION OF CHECKERED PLATES**





# **BUILDING ACCESSORIES**

**C  
H  
A  
P  
T  
E  
R**

**13**

# Building Accessories

13.1	General .....	323
13.2	Personnel Walk Doors .....	324
13.3	Windows .....	328
13.4	Sliding Doors .....	330
13.5	Roll-Up Doors .....	336
13.6	Framed Openings .....	341
13.7	Ventilators	
13.7.1	General .....	345
13.7.2	Gravity Ventilators .....	349
13.7.3	Power Ventilators .....	355
13.8	Louvers	
13.8.1	General .....	358
13.8.2	Fixed Louvers .....	360
13.8.3	Adjustable Louvers .....	363
13.9	Roof Curbs .....	366
13.10	Translucent Panels .....	369
13.11	Suspended Ceilings .....	372

A basic Zamil Steel building is comprised of primary rigid frames, secondary structural members (roof, purlins, wall girts, eave struts), bracing systems (diagonal X-bracing or portal frames), post & beam endwalls (corner columns, endwall wind columns & load bearing rafters) and sheeting (roof and wall panels).

**Building accessories** consists of two categories:

- Manufactured items (by Zamil Steel) such as sliding doors.
- Special buyout items that are manufactured by others according to specifications that are unique to Zamil Steel. Such items include insulation (see **chapter 14**), personnel walk doors, roll-up doors, windows, louvers, ventilators, etc.

Building accessories enable a basic Zamil Steel building to be customized according to functional requirements.

This chapter lists the building accessories that are most common to pre-engineered buildings and highlights the interface details for incorporating these accessories in Zamil Steel pre-engineered buildings economically & aesthetically.



Zamil Steel supplies two types of personnel walk doors: **single personnel doors** and **double personnel doors**.

Single personnel doors are available in one standard size: 915 mm wide x 2135 mm long. Double personnel doors are available in one standard size: 1829 mm wide x 2135 mm long.

Doors are designed in accordance with the American National Standard Test Procedure and Acceptance Criteria for physical endurance.

### Door Frames

Door frames are fabricated from 1.5 mm cold-formed steel, galvanized according to specification ASTM A525 M (Z-180) classification. The frames are treated with a metal-prepared zinc-chromate wash and painted in a white finish. They are delivered to site in a knocked-down condition.

Frame head attachments are field-bolted to the secondary structural members of the building. However, the holes in girts are field located.

The door frame base clip is flush welded to the bottom of the frame at the factory and anchored to the concrete slab with 12 mm diameter expansion bolts.

### Door Leaf

Single and double door leaves are flush, 44 mm thick, solid or factory glazed with a 5 mm thick clear tempered side vision glass.

The door leaf is reversible for left or right hand swing and may be installed to open from inside or outside. The leaf is fabricated from leather grained embossed cold-rolled steel of 0.9 mm minimum thickness and painted with a white finish. It is stiffened and sound deadened with a honeycomb core or polystyrene. The core is impregnated with

water resistant resin and has a crush strength of 0.02 kN/cm<sup>2</sup>.

Doors have full mortise *hinge* preparation with 4 mm hinge reinforcement. Each door leaf has three mortise hinges (115 mm x 115 mm) with ball bearings, for moderate use, and a nonremovable stainless steel pin. The finish is dull chrome.

The *lockset* is a key type cylindrical lockset with dull chrome finish.

A “Z” shaped astragal is furnished for all double leaf doors and painted with white color.

*Panic devices, thresholds, weather stripping, and door closers* are optional and may be supplied at additional cost.



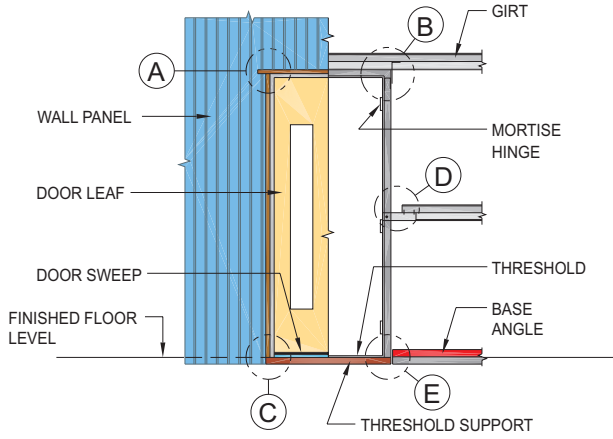

**ELEVATION** : SINGLE PERSONNEL DOOR

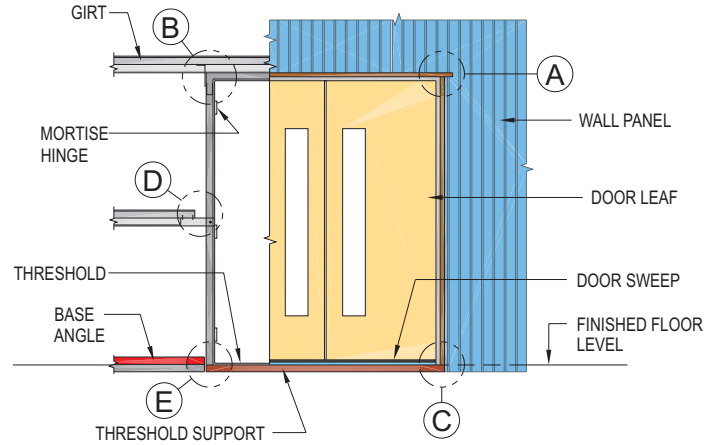

**ELEVATION** : DOUBLE PERSONNEL DOOR

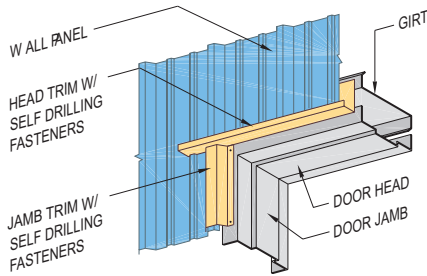

**DETAIL-A**

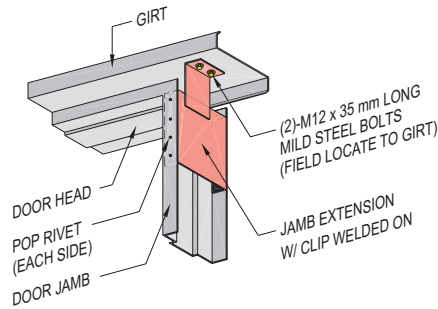

**DETAIL-B**

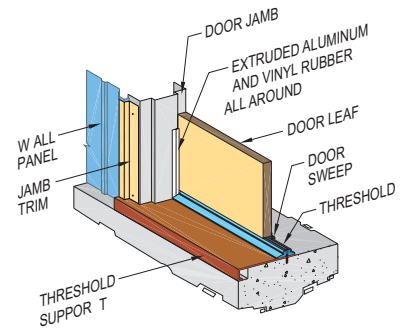

**DETAIL-C**

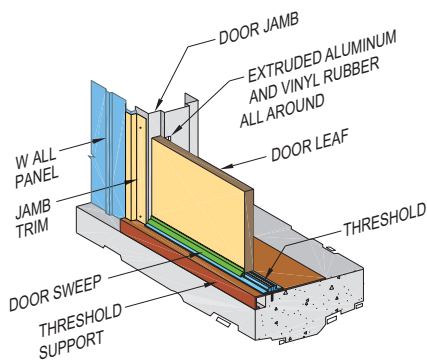

**DETAIL-C**

(OUT SWING DOOR LEAF POSITION)

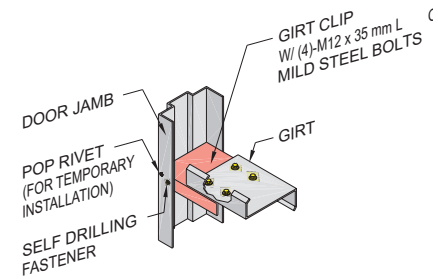

**DETAIL-D**

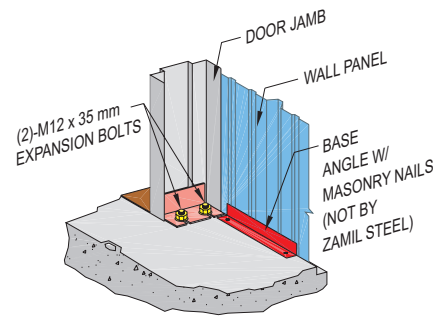

**DETAIL-E**

**PERSONNEL DOOR AT SINGLE SKIN WALL PANEL**

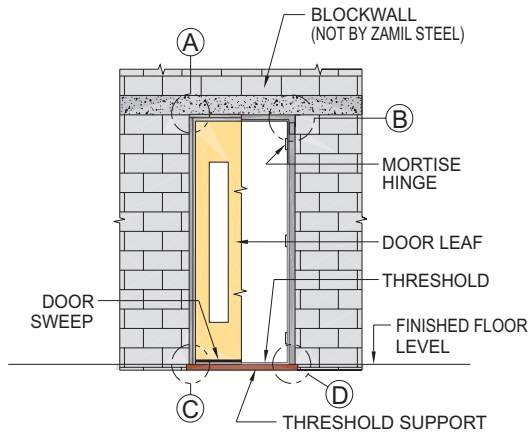

**ELEVATION** : SINGLE PERSONNEL DOOR

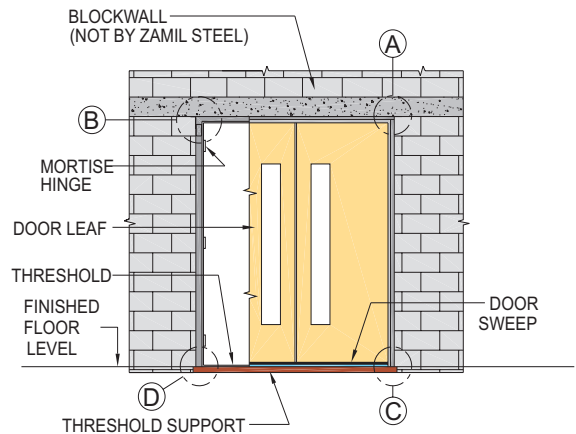

**ELEVATION** : DOUBLE PERSONNEL DOOR

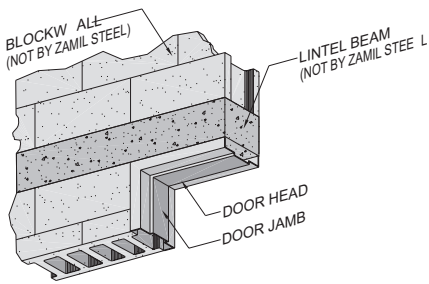

**DETAIL-A**

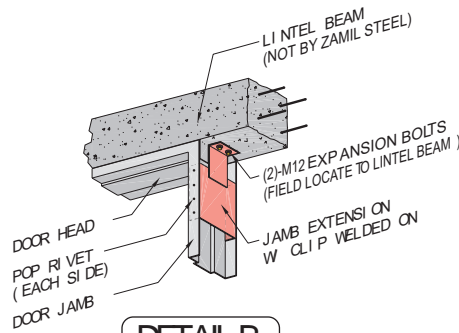

**DETAIL-B**

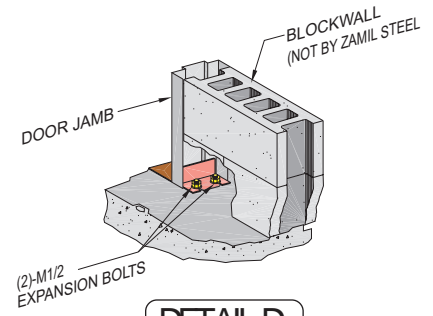

**DETAIL-D**

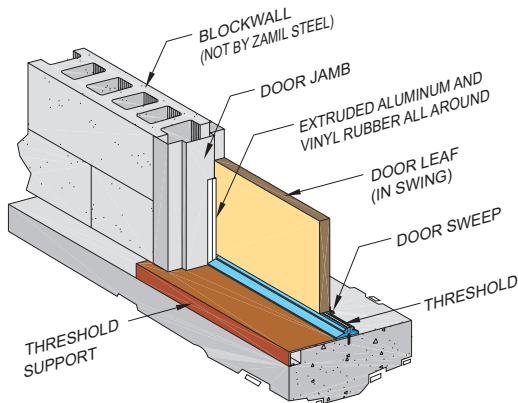

**DETAIL-C**

(IN SWING DOOR LEAF POSITION)

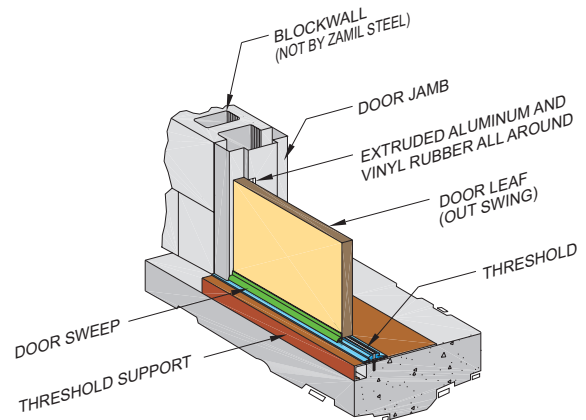

**DETAIL-C**

(OUT SWING DOOR LEAF POSITION)

**PERSONNEL DOOR AT BLOCKWALL**

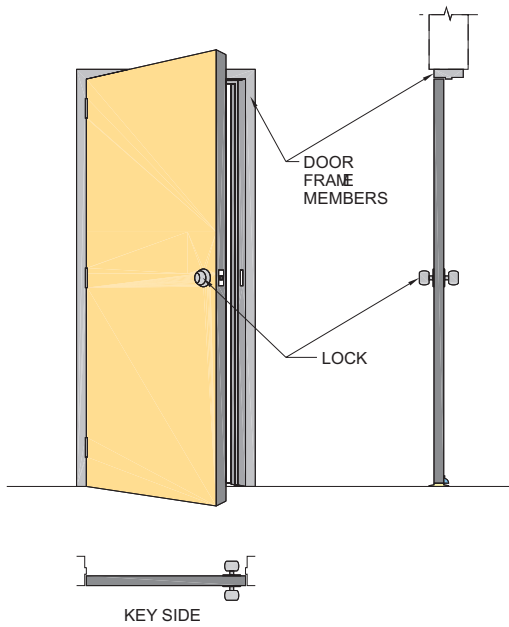

**SINGLE SOLID DOOR WITH CYLINDER LOCK**  
(SIDE VISION DOORS ALSO AVAILABLE)

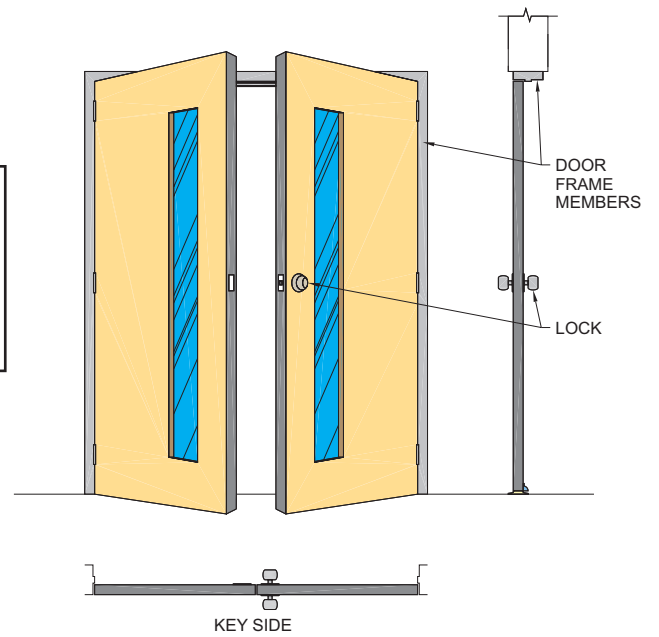

**DOUBLE SIDE VISION DOOR WITH CYLINDER LOCK**  
(SOLID DOORS ALSO AVAILABLE)

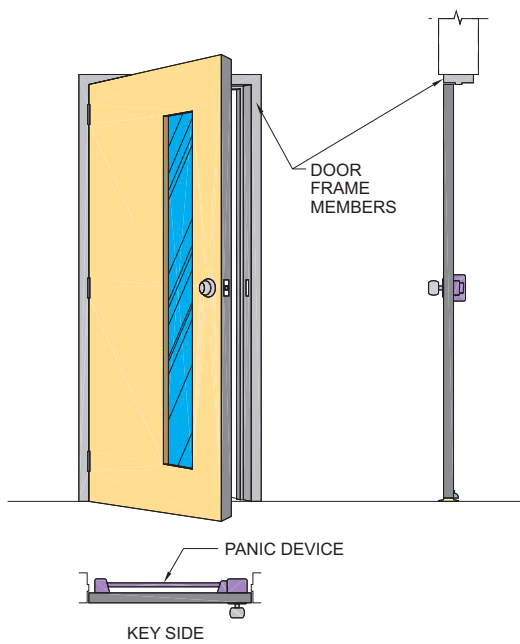

**SINGLE SIDE VISION DOOR WITH PANIC DEVICE**  
(SOLID DOORS ALSO AVAILABLE)

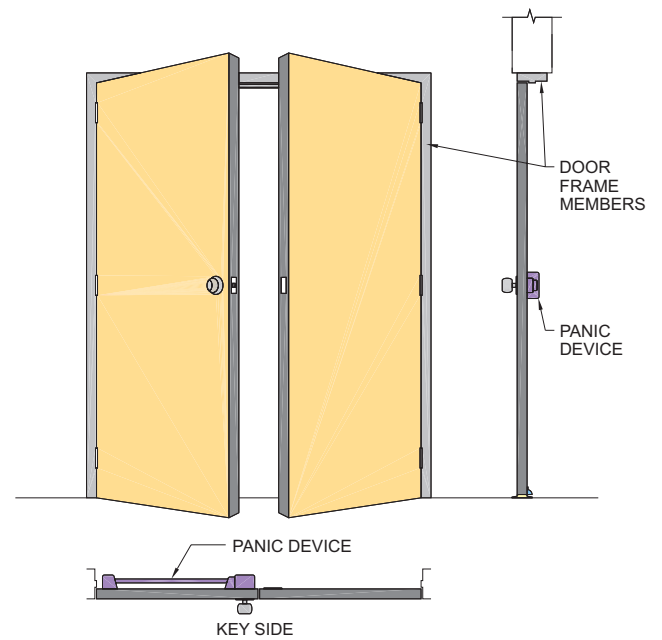

**DOUBLE SOLID DOOR WITH PANIC DEVICE**  
(SIDE VISION DOORS ALSO AVAILABLE)

Zamil Steel aluminum windows are designed specifically for Zamil Steel pre-engineered buildings. Windows are two-leafed horizontal half-slide type made from aluminum. The aluminum extrusions serve as flashing for the head, jambs and sill sections. They are completely assembled, factory glazed, with a single leaf insect screen and shipped ready for installation.

Aluminum extrusions used for the main frame, mullion sections and sash sections are tempered aluminum alloy equivalent to alloy type 6063 T6 of ASTM B221.

The main frame and mullion of the window have a nominal wall thickness not less than 1.3 mm.

Fasteners, washers and nuts, used in the window fabrication, are made of material that is non corrosive to aluminum, compatible, and sufficient to perform the fastening functions for which they are intended.

Standard window glazing consists of a single 4 mm thick clear glass. Sliding sash has full weather strips.

The glazing bead is made of extruded neoprene or vinyl and provides a weathertight seal.

The frames of the screen are sufficiently rigid to lay flat against the window without causing excessive bending in the frame members or sag in the screen.

Screen and screen spline are made of aluminum or a material compatible with aluminum.

The surface finish of all aluminum extrusions and aluminum assemblies is a naturally anodized coating with a minimum thickness of 15 microns.

Standard window sizes are:

- 1000 mm wide x 1000 mm high
- 1500 mm wide x 1000 mm high





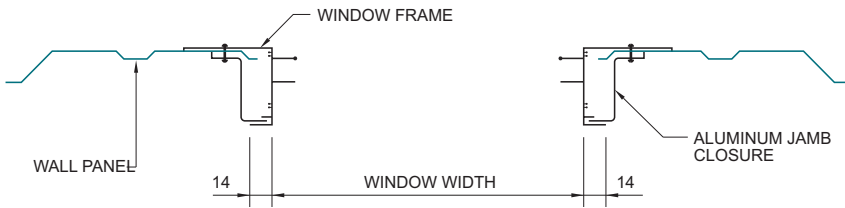

**SECTION-A** : AT JAMBS  
(FOR SINGLE SKIN PANEL)

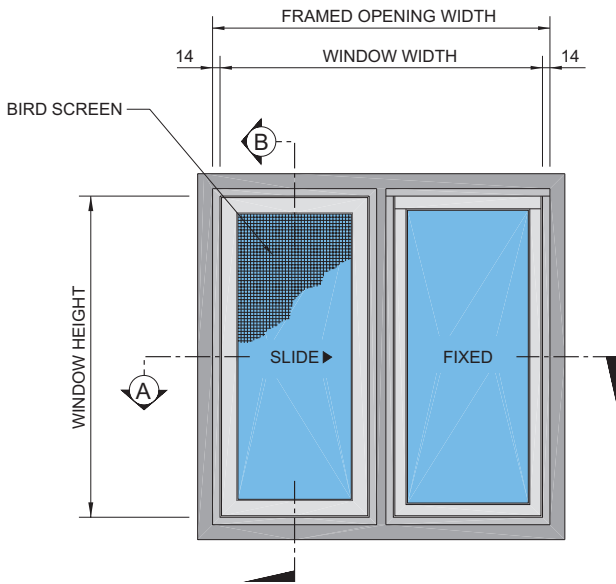

**ELEVATION** : FRONT VIEW OF WINDOW

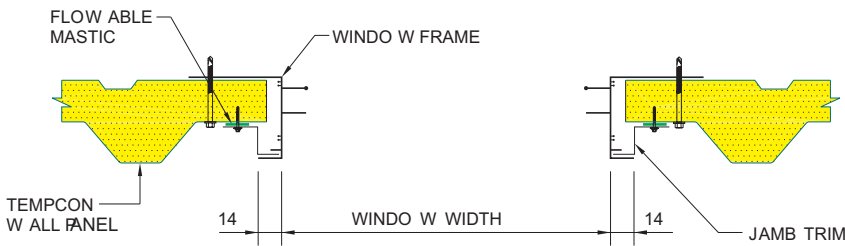

**SECTION-A** : AT JAMBS  
(FOR TEMPCON PANEL)

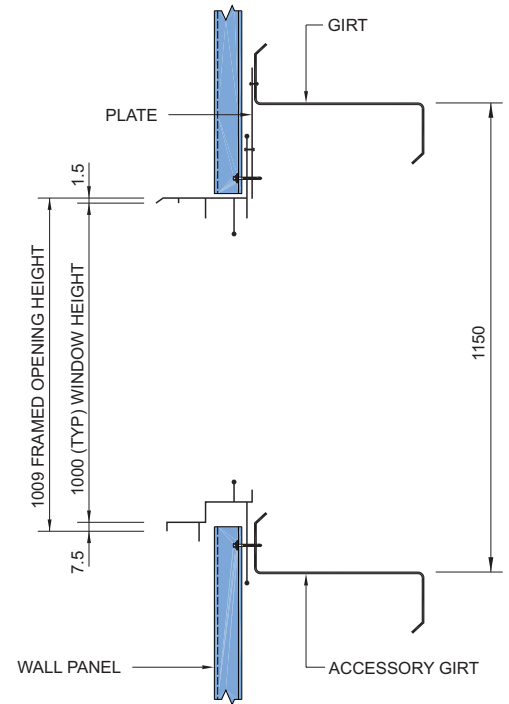

**SECTION-B** : AT HEAD & SILL  
(FOR SINGLE SKIN PANEL)

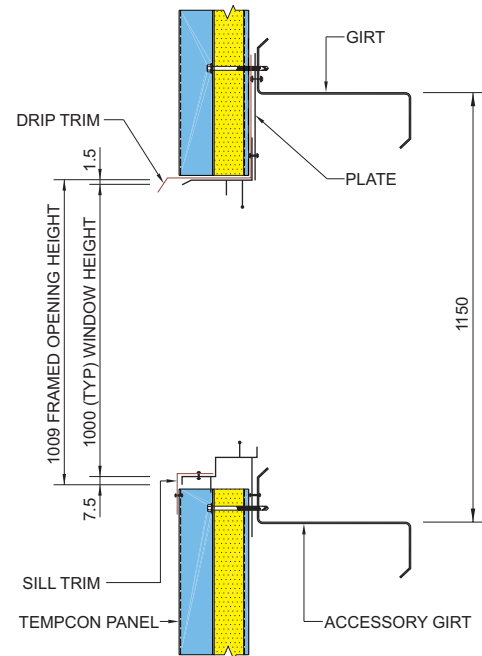

**SECTION-B** : AT HEAD & SILL  
(FOR TEMPCON PANEL)

**DETAIL** : WINDOW AT SINGLE SKIN WALL PANEL AND AT TEMPCON WALL PANEL

Zamil Steel supplies both **single sliding doors** and **double sliding doors**.

Standard single sliding doors slide horizontally in one direction whereas the leaves of double sliding doors slide in opposite directions.

The framing of the door is made from galvanized cold-formed channels having a yield strength of 34.5 kN/cm<sup>2</sup> and a minimum thickness of 2.0 mm. It is delivered knocked-down for field assembly. The door leaves are sheeted with 0.5 mm pre-painted Zinalume panels normally matching the color of the wall panels. The interior liner (optional) of the sliding door shall be made from 0.5 mm Profile “C” panel matching the color of the interior wall liner.

Zamil Steel double sliding doors are designed for quick assembly and ease of operation and are in three types:

- Type T1 (Top hanging support with projecting bottom guide).
- Type T2 (Top hanging support with grooved bottom guide)
- Type B1 (Top guide with bottom roller support)

Type T1 double sliding doors are suspended from a 1.5 mm thick galvanized steel trolley rail that is attached to a built-up door header and guided at the bottom by a projecting guide. The trolley truck has 4 wheels whose axles are mounted on hardened steel roller bearings and a one-piece galvanized steel casting truck body.

Type T2 double sliding doors are identical to type T1 double sliding doors except for the bottom guide, which is grooved and embedded in the concrete ramp. A plate connected to the bottom member of the door leaf slides through the groove, thereby, guiding the horizontal movement of the door.

Type B1 double sliding doors are guided by a top guide that runs on a top track which is connected to a cold-formed header. The bottom of the door leaves is supported by rollers, which travel along a roller guide that is embedded in the concrete ramp.

Zamil Steel manufactures the three types of double sliding doors in any combination of width and length up to a maximum size of 6000 mm x 6000 mm.

Field assembly and installation of double sliding doors is made in accordance with the erection drawings and instructions issued by Zamil Steel.



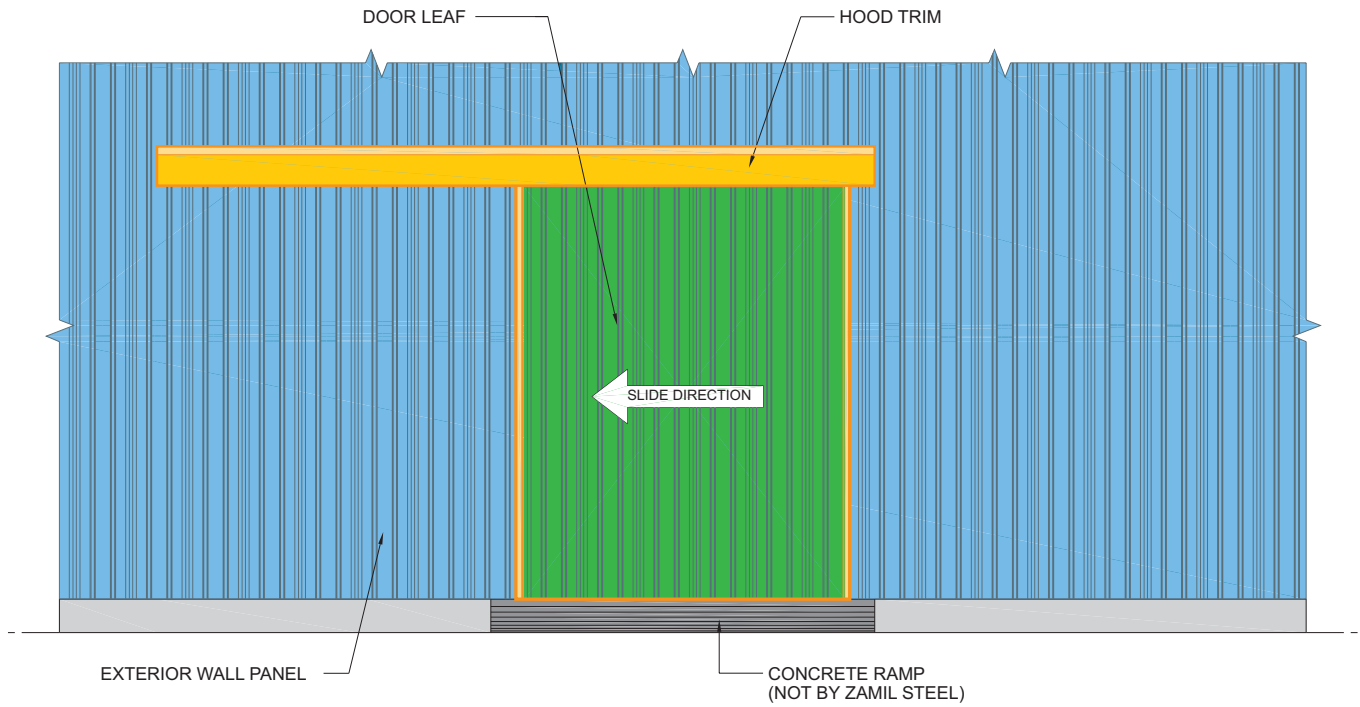

**ELEVATION** : SINGLE SLIDING DOOR

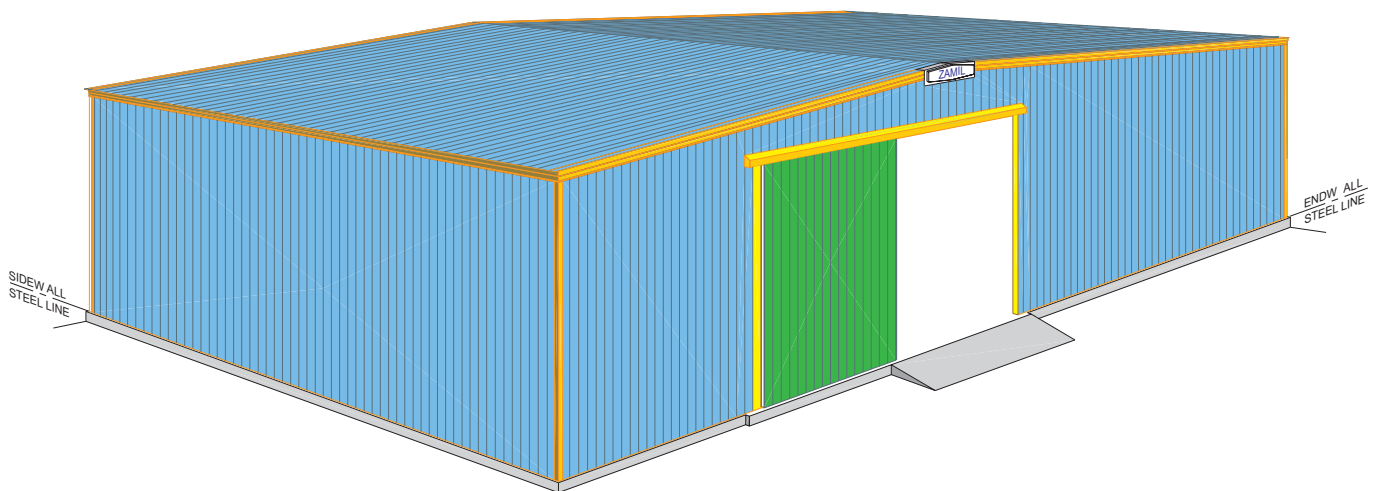

**ISOMETRIC** : SINGLE SLIDING DOOR AT FULLY SHEETED WALLS

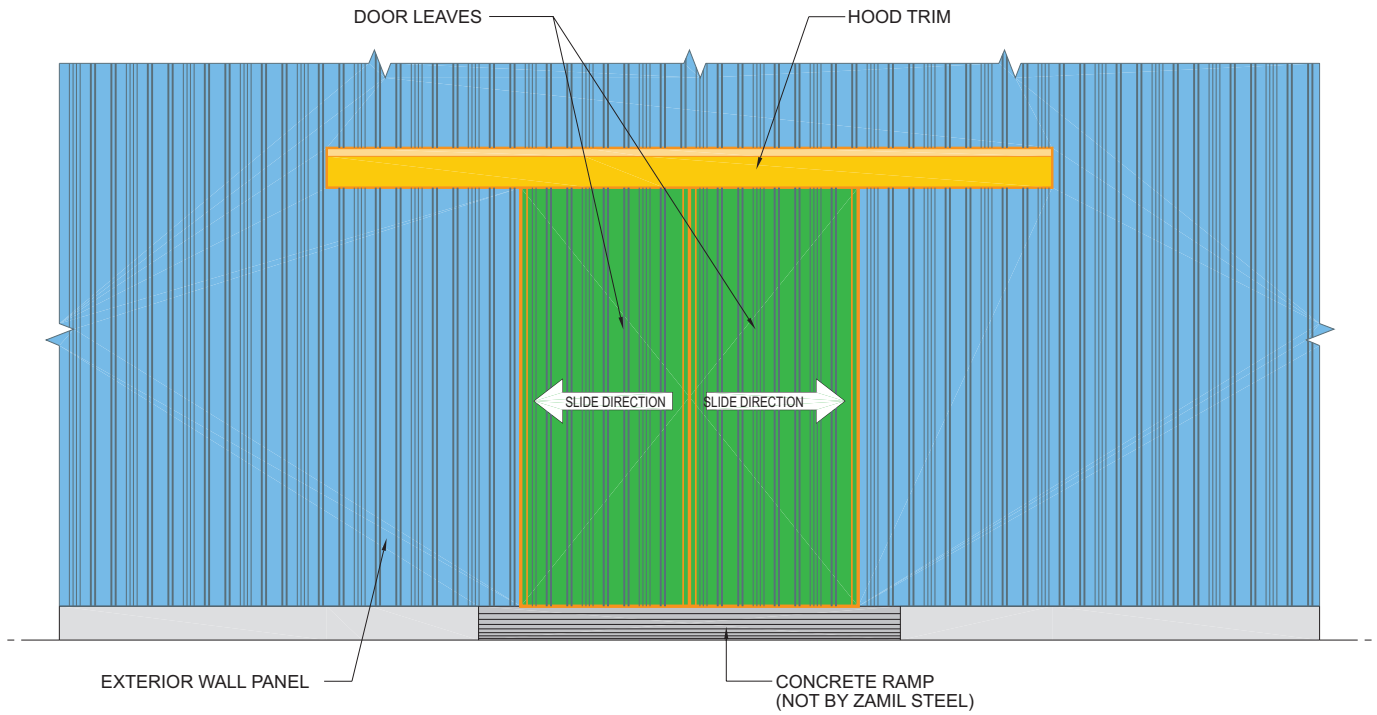

**ELEVATION** : DOUBLE SLIDING DOOR

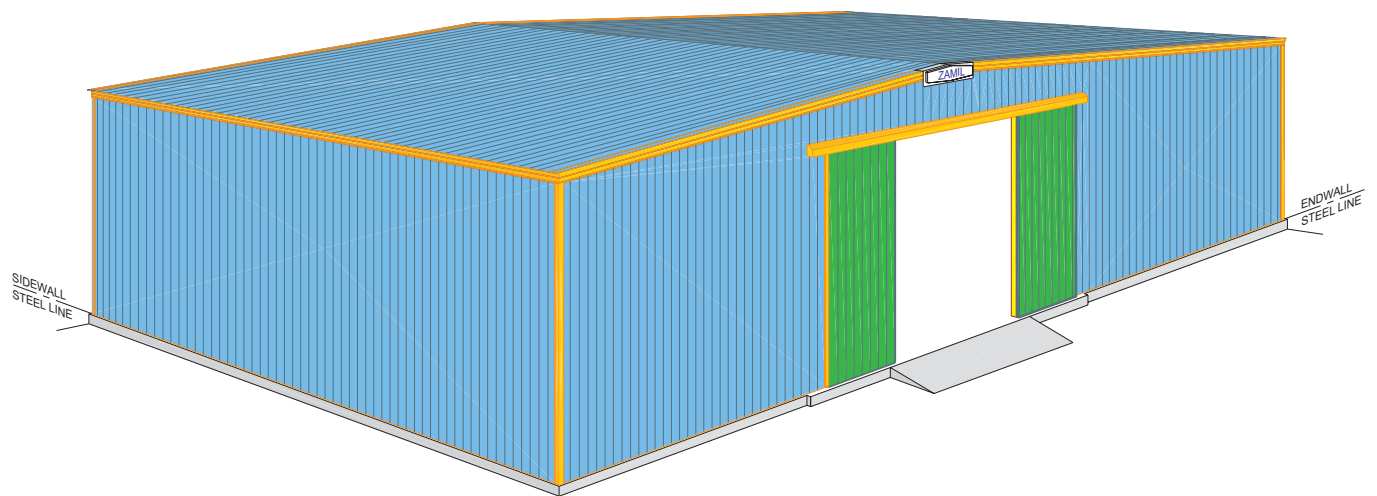

**ISOMETRIC** : DOUBLE SLIDING DOOR AT FULLY SHEETED WALLS

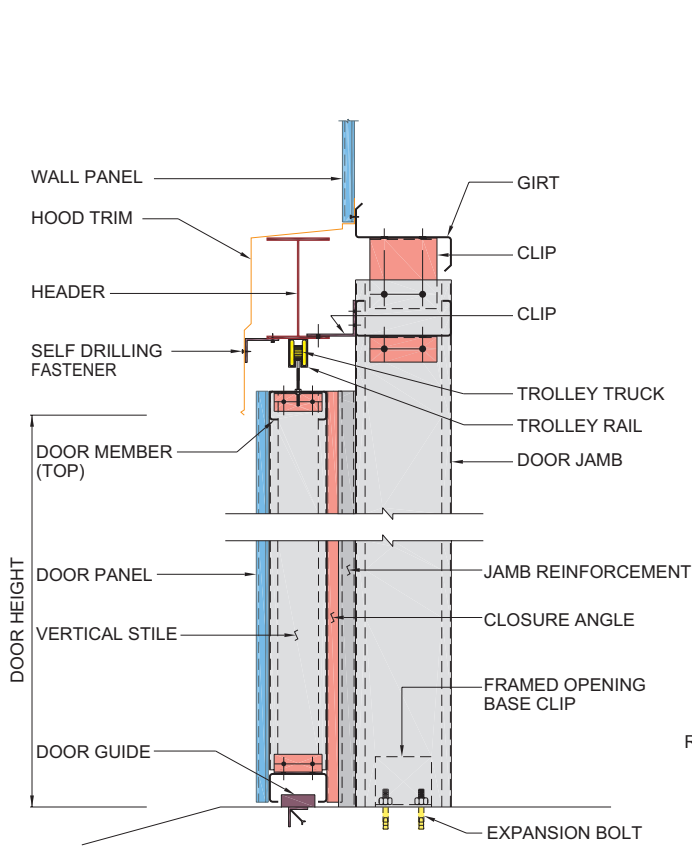

**SECTION I** : DOOR AND FRAMED OPENING

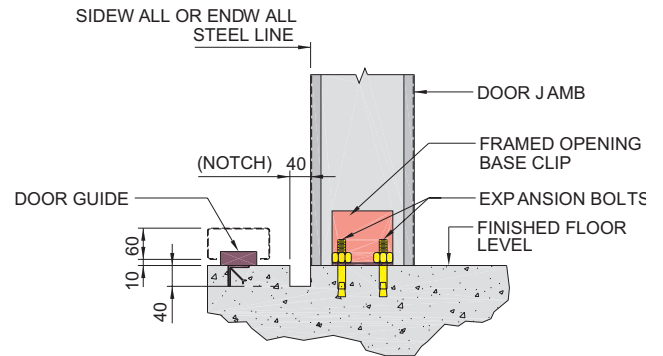

**SECTION M**

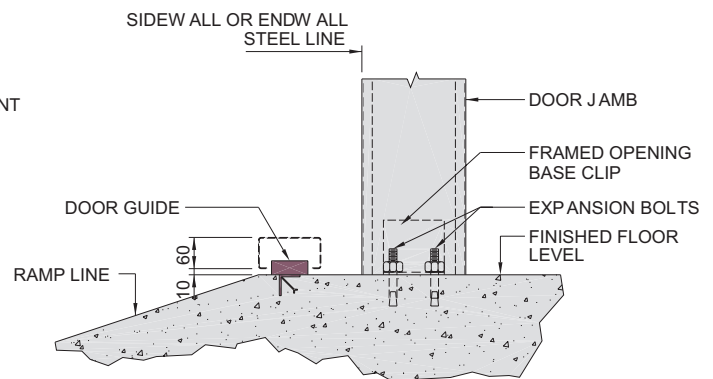

**SECTION N**

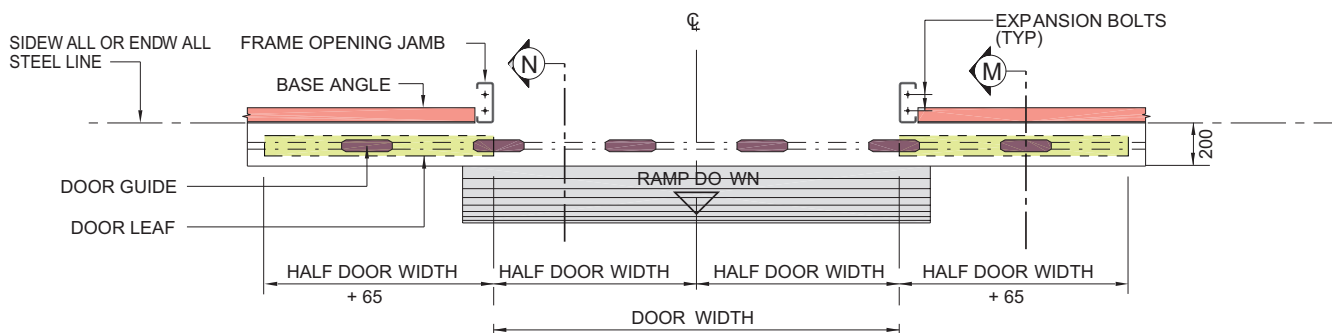

**PLAN** : ANCHOR BOLT SETTING

**DETAILS** : TYPE 'T1' SLIDING DOOR

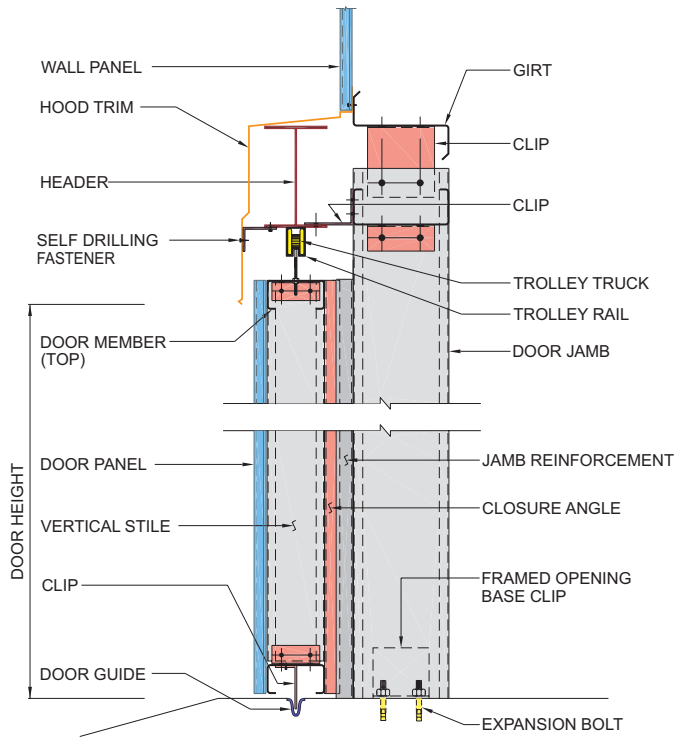

SECTION : DOOR AND FRAMED OPENING

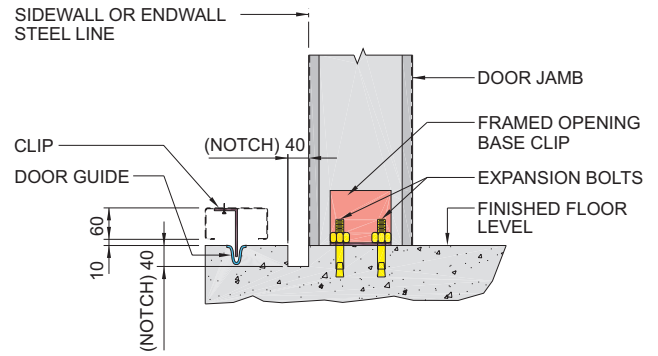

SECTION-M

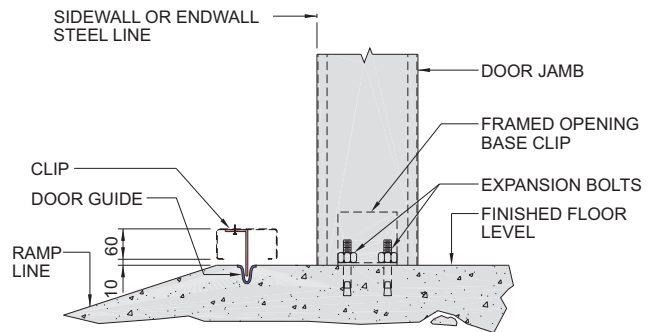

SECTION-N

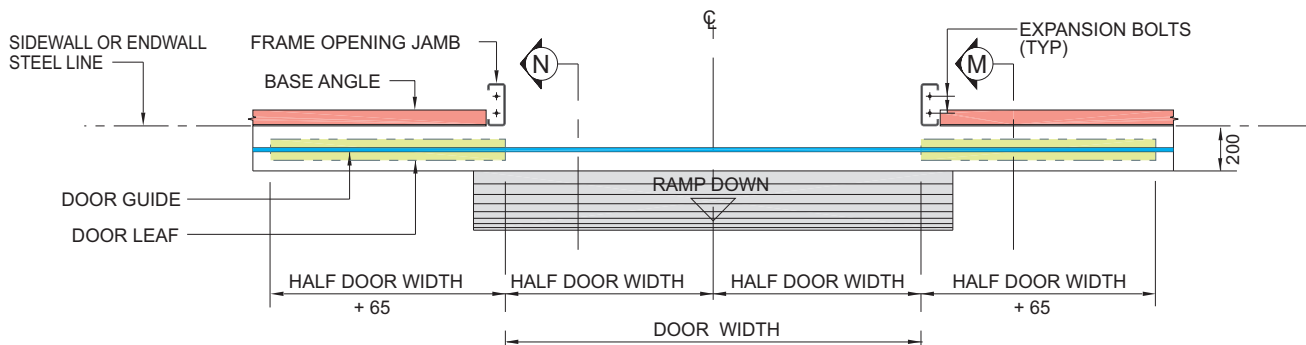

PLAN : ANCHOR BOLT SETTING

DETAILS : TYPE 'T2' SLIDING DOOR

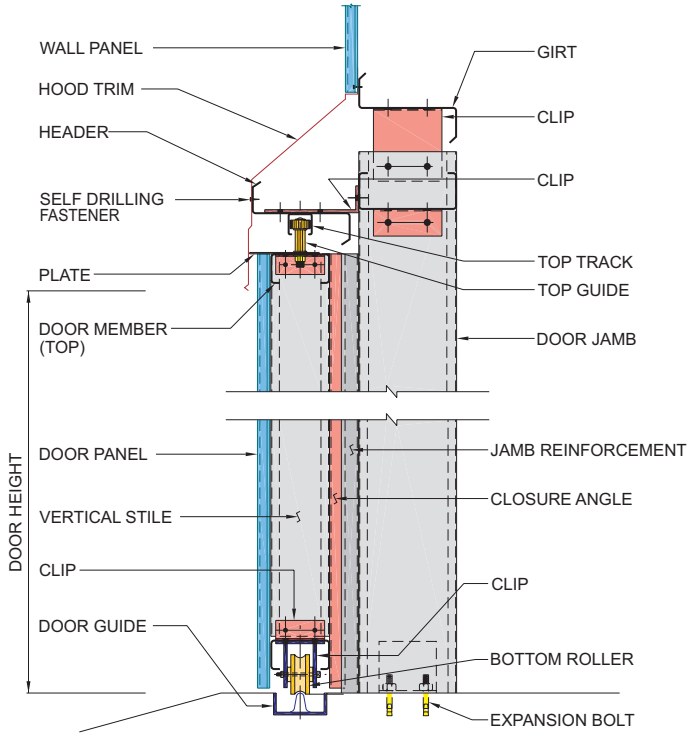

**SECTION** : DOOR AND FRAMED OPENING

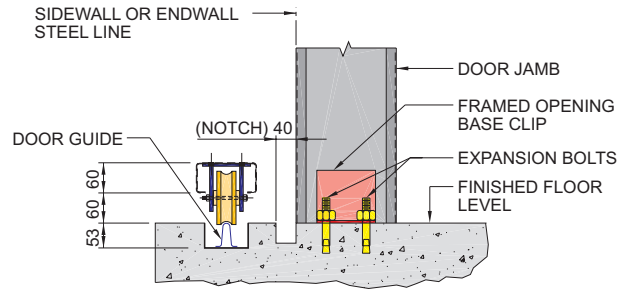

**SECTION-M**

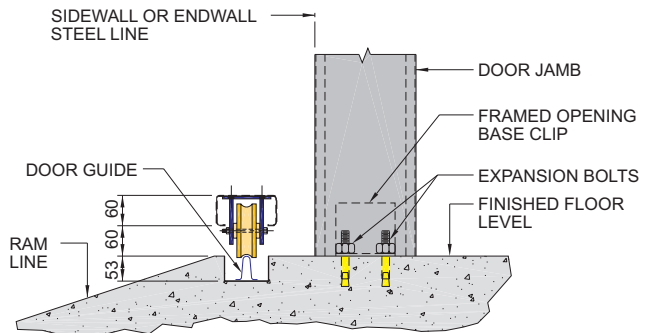

**SECTION-N**

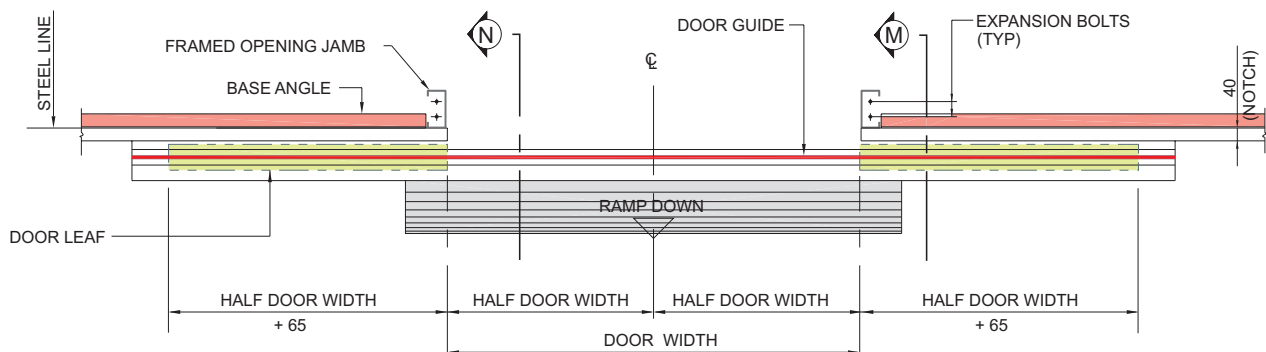

**PLAN** : ANCHOR BOLT SETTING

**DETAILS** : TYPE 'B1' SLIDING DOOR

Zamil Steel supplies two types of roll-up doors: *manually operated roll-up doors and electrically operated roll-up doors.*

Zamil Steel roll-up doors are designed to be attractive, long lasting and easy to operate. Doors are supplied complete with guides, axles, springs, curtains and weather stripping (for the sides and bottom) and are manufactured and assembled by Zamil Aluminum Industries (Dammam) under an agreement with Trevor Doors of Australia.

Each manually operated roll-up door unit is chain-operated manually. Electrically operated roll-up doors are supplied with additional chain equipment to work manually in case of a power failure.

A Trevor roll-up door comprises of a *curtain* formed from the individual interlocking of steel slats that are made of cold-formed steel. The curtain runs in vertical channel guides and coils around a drum at the top of the opening and is designed to accommodate pressures from wind speeds of up to 160 km/h for the maximum shutter width of 5 meters. Curtain widths exceeding 5 meters require windlocking to maintain the strength for the prescribed wind loadings.

The roll-up door curtain is constructed of interlocking curved profile slats. The width of the individual slat is 75 mm and the thickness of the material is 1.0 mm. The slats are cold roll formed using a zinc/aluminium coated alloy. The alloy coating comprises 55% aluminium, 43.5% zinc and 1.5% silicon that provides strong corrosion resistant qualities.

The profile of the Trevor 75 mm slat allows for an extremely smooth and quiet roll. The design of the interlocking curls are so arranged that rain and dust on the weather face of the shutter does not enter the hinged joint, thus providing a self-draining weather-resisting shield. The slats are pre-painted using a silicon modified polyester coating. This coating is

applied during the production of the steel coil prior to the roll forming of the slat. This process allows a consistent high quality finish to the product.

The curtain slats are secured in position using nylon *clips* on alternate slats. These curtain clips prevent the slats from moving sideways thereby preventing the curtain from jamming. The design of the clips also serve to reduce noise caused from the slats rubbing on the guide channels.

The *bottom rail* is manufactured from a specially designed extruded aluminium section. The design incorporates a bottom rail weather seal housing.





The drum bracket is made of 8 mm thick mild steel and is bent to form a 76 mm perpendicular foot. These brackets support the drum and curtain assembly. They are attached to the inside wall of the building, providing drive gear ends to suit the type and arrangement of the roller shutter. All brackets are factory prime painted with a zinc chromate coating to provide corrosion protection.

The curtain of the roll-up door is supported by a robust steel drum tube. The *drum* has a wall thickness of 3.2 mm and a diameter of 165.4 mm. The drum is uniquely designed to give a high factor of operating safety and minimum deflection. The drum accommodates the springs, shaft, collars and bearings. The springs are designed to counter balance the weight of the shutter assembly.

The *guide* sections of the roll-up doors are produced from 2.5 mm thick mild steel strips that are hot dip galvanized then cold-formed into channel sections. After forming, the channel sections have a width of 100 mm. The top of both guide channels are flared outwards and the flanges welded for the ease of curtain entry into the channels. Roll-up doors are secured with pad bolts.

Motor operated Trevor roll-up doors are operated from the right hand end. An electric motor and the gearbox units are fitted to all roll-up doors. Standard voltages for these units are either 220 volt single phase or 380 volt three phase. Motor units are supplied complete with contactor boxes but do not include wiring. Motor operated roll-up doors may be secured with pad bolts.

Standard Zamil Steel roll-up doors sizes are listed below:

Width (mm)	Height (mm)
3000	3000
3000	4000
4000	4000
4000	5000
5000	5000

Other custom sizes can be made to fit the requirements of the customer.

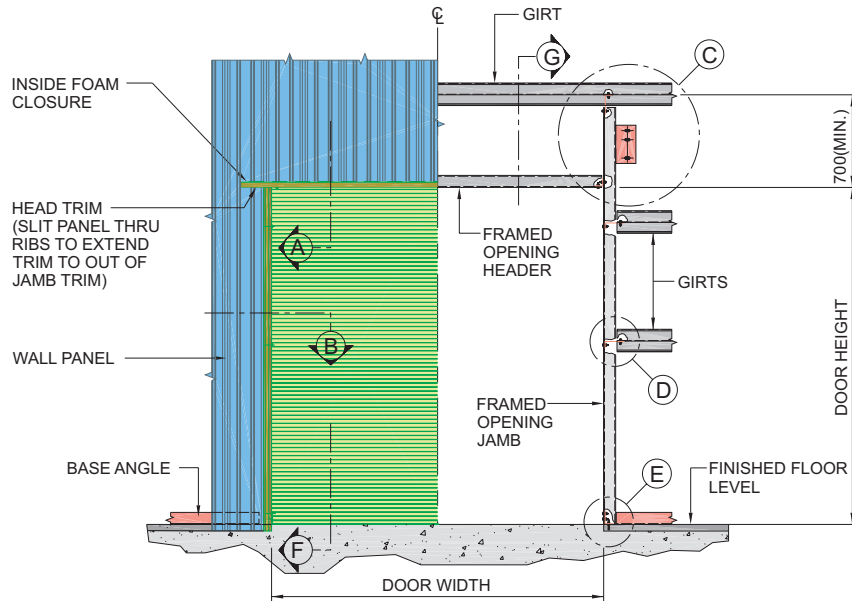

NOTE:  
SEE PAGE 5 OF 5 OF  
THIS SECTION FOR  
DRAWING DETAILS.

**ELEVATION** : ROLL-UP DOOR

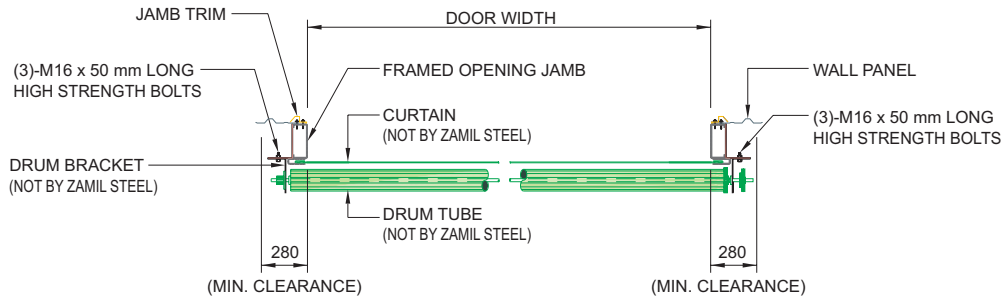

**PLAN** : ROLL-UP DOOR

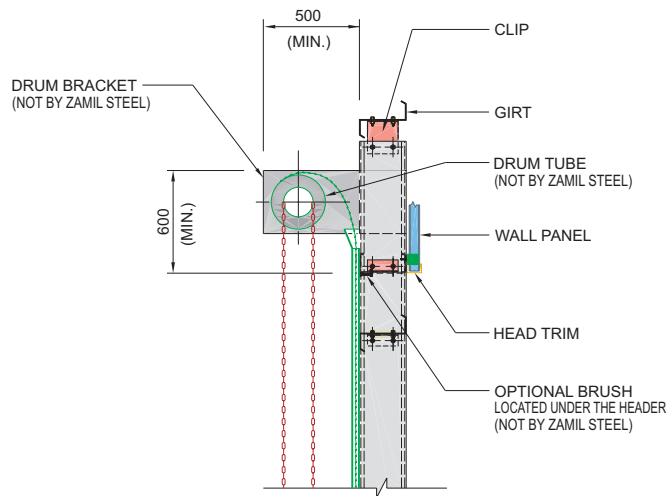

**SECTION G**

**ROLL-UP DOOR (MANUAL) AT FULLY SHEETED WALLS**

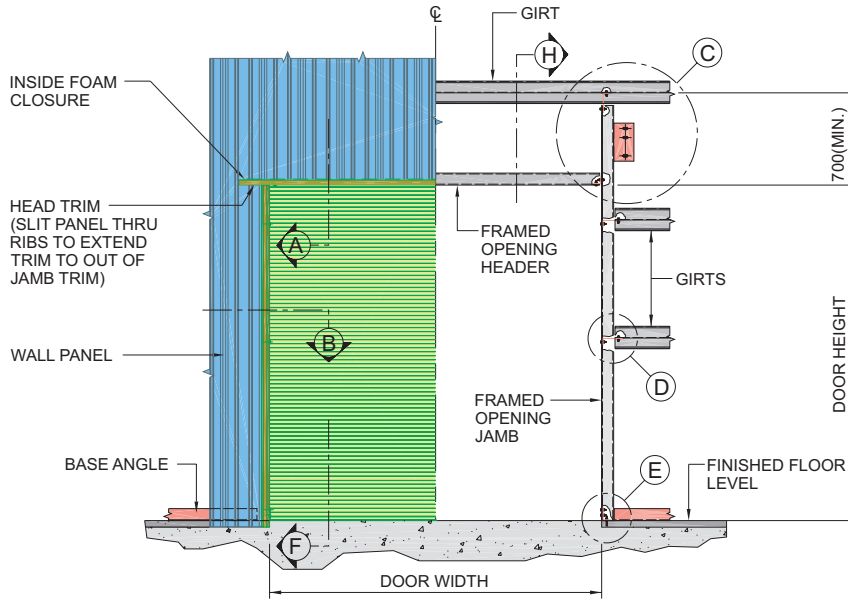

NOTE:  
SEE PAGE 5 OF 5 OF  
THIS SECTION FOR  
DRAWING DETAILS.

**ELEVATION** : ROLL-UP DOOR

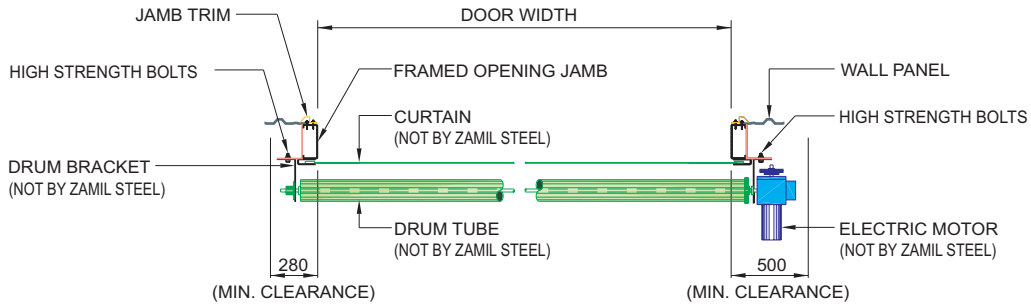

**PLAN** : ROLL-UP DOOR

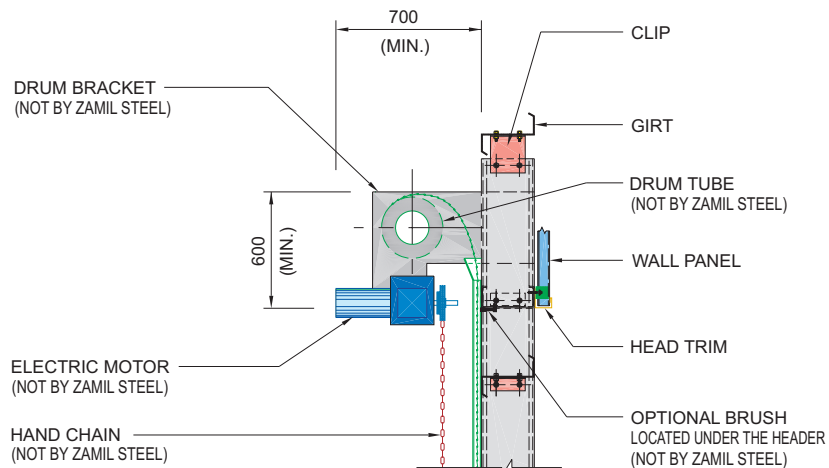

**SECTION H**

**ROLL-UP DOOR (ELECTRIC) AT FULLY SHEETED WALLS**

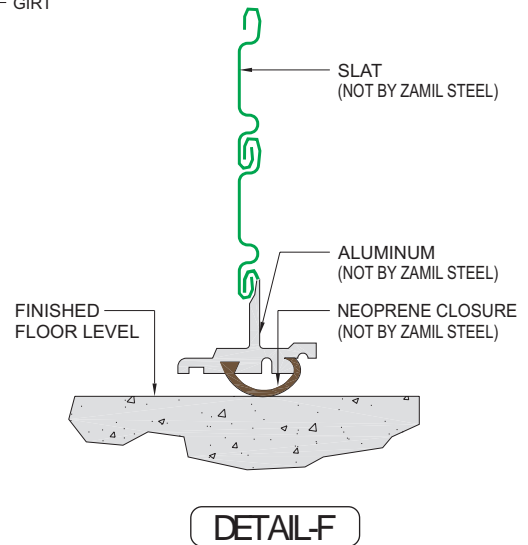
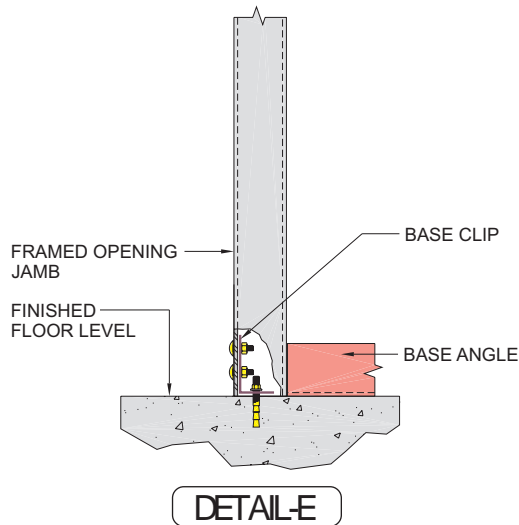
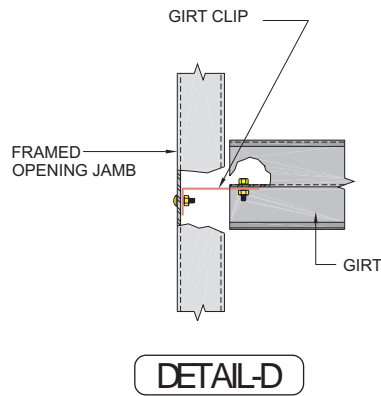
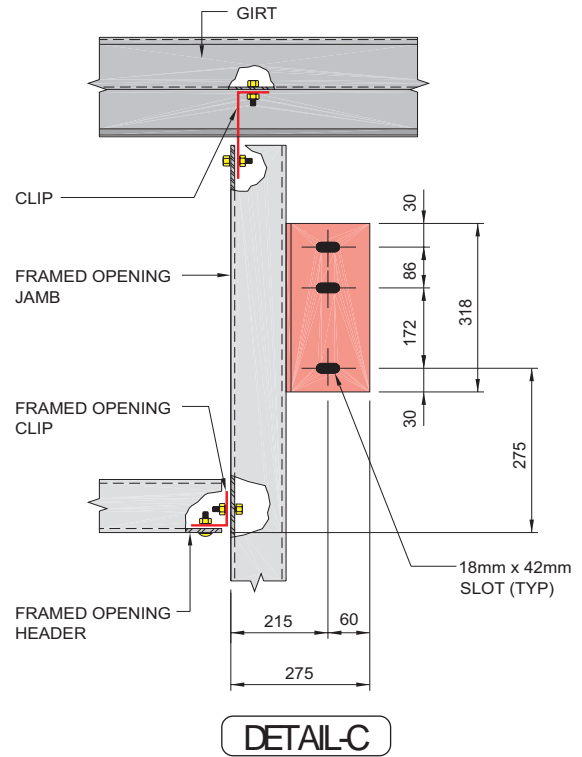
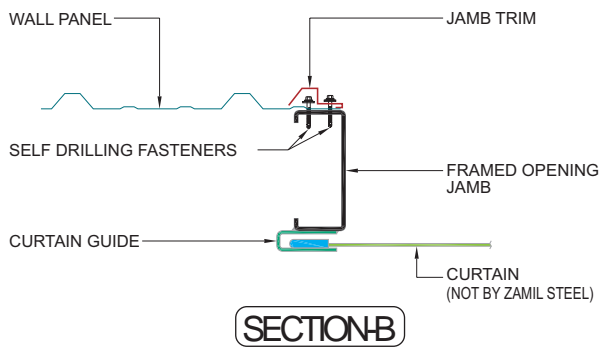
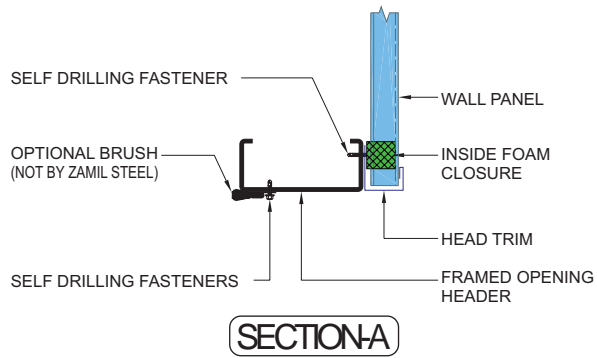

**Framed openings** are provided in walls and roofs to accommodate special accessories that are not made or supplied by Zamil Steel.

The framing details described in this section are for standard framed openings. For complex conditions requiring special framing, the highly trained and experienced staff of Zamil Steel Engineering Department can design and develop the right framed openings you need.

### **Framed Openings in Roofs**

Framed openings in the roof are designed to support lightweight equipment such as fans, air conditioning package units, special gravity or power ventilators and other roof accessories which should not or could not be mounted directly on the roof framing or the roof panels.

### **Framed Openings in Walls**

Framed openings in the walls are commonly used to accommodate special doors, windows, louvers, exhaust fans, etc.



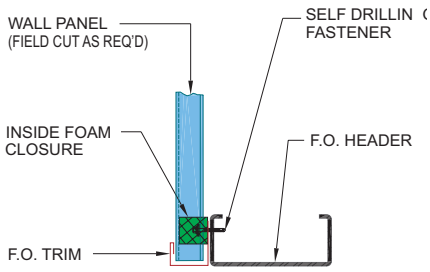

SECTION-A

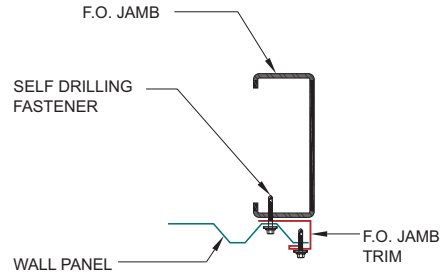

SECTION-B

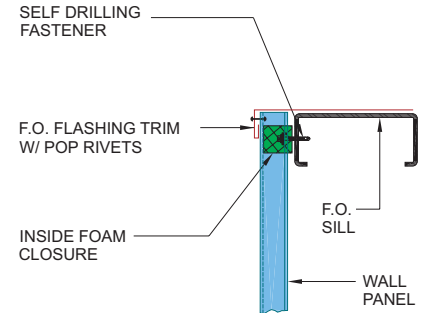

SECTION-C

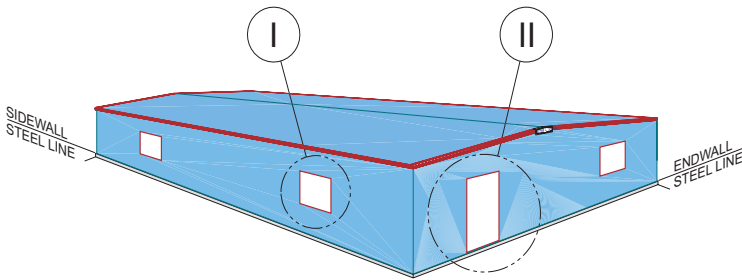

ISOMETRIC : FRAMED OPENING IN WALL

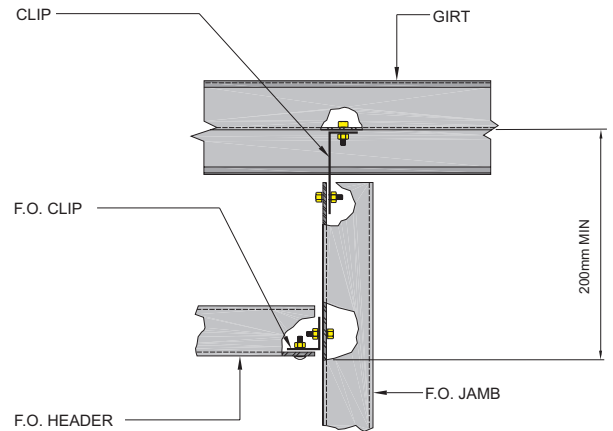

DETAIL-D

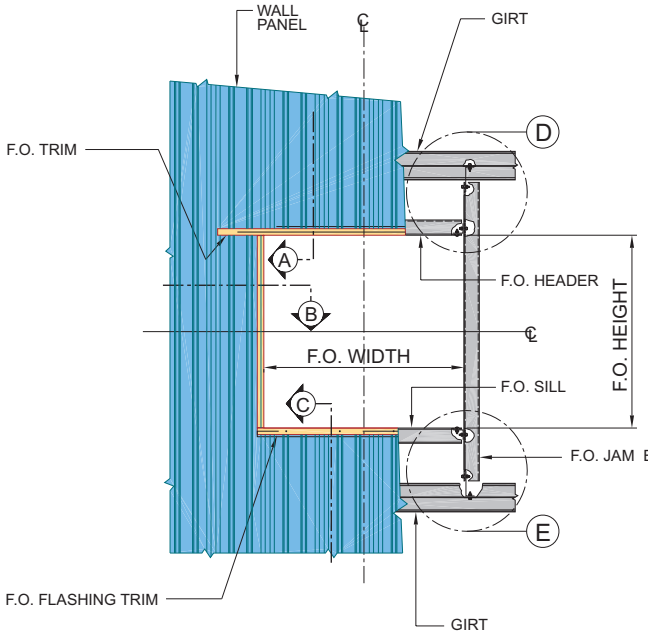

DETAIL-I

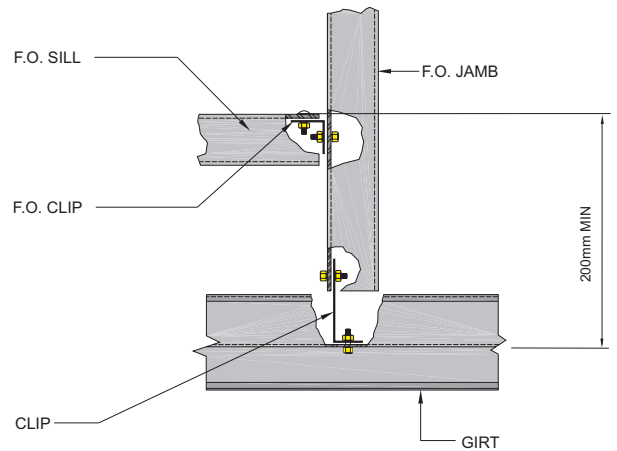

DETAIL-E

ELEVATION : FRAMED OPENING IN WALL BETWEEN GIRTS

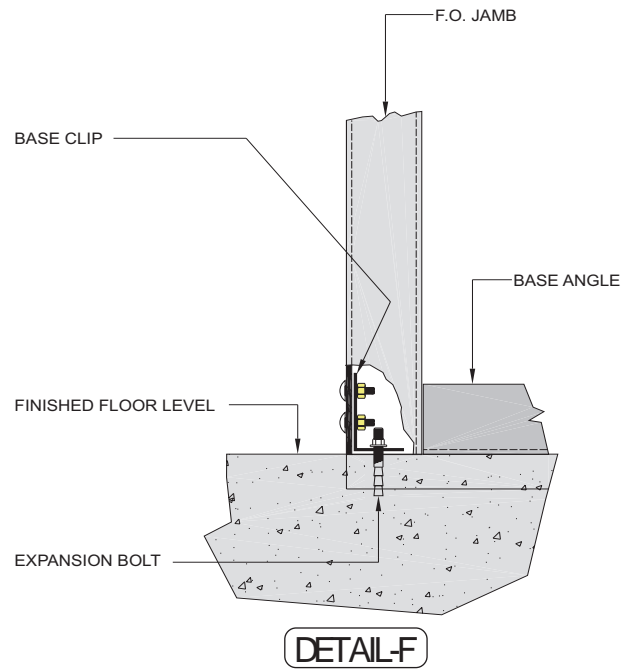
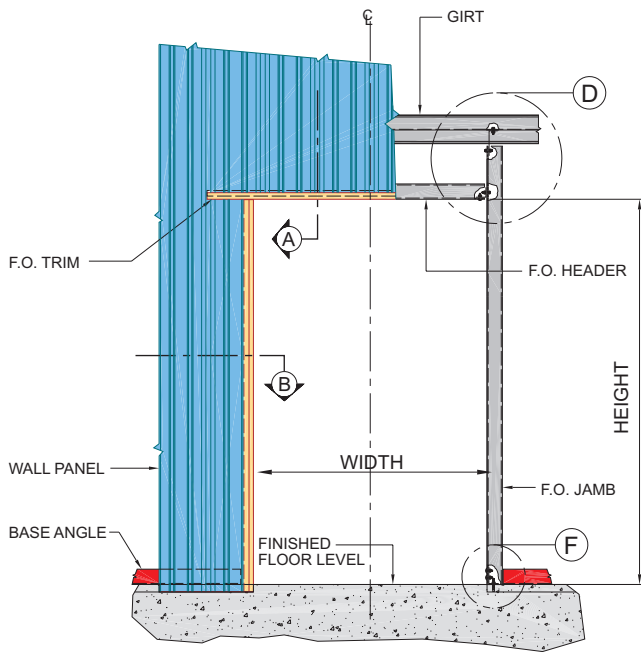

**DETAIL-II** : FRAMED OPENING IN WALL FROM FLOOR LINE TO FIRST GIRTS LEVEL

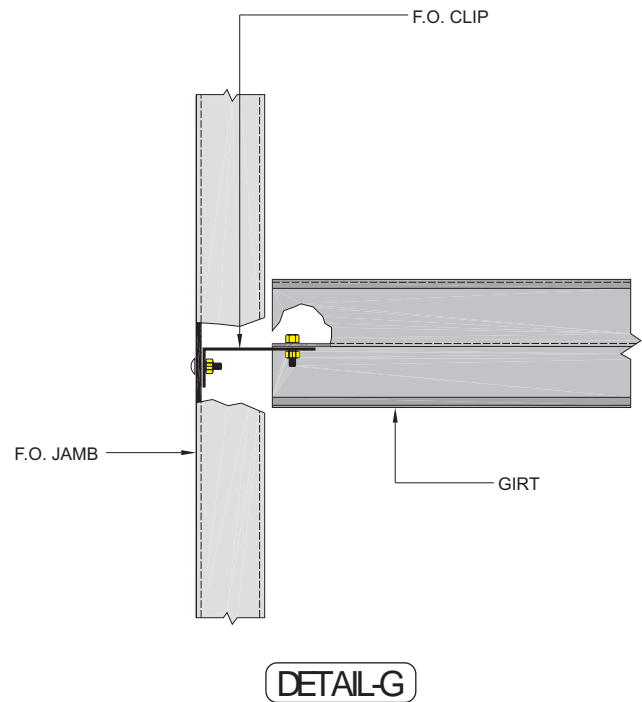
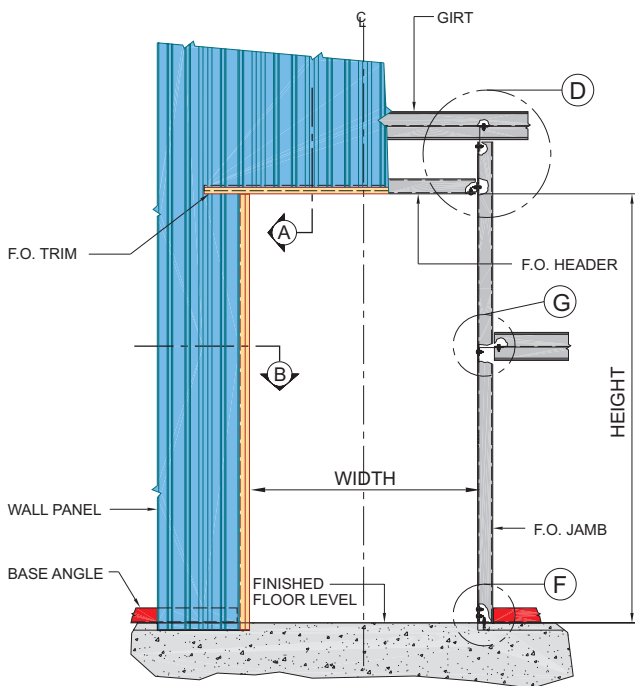

**DETAIL-II** : FRAMED OPENING IN WALL FROM FLOOR LINE TO ANY HEIGHT

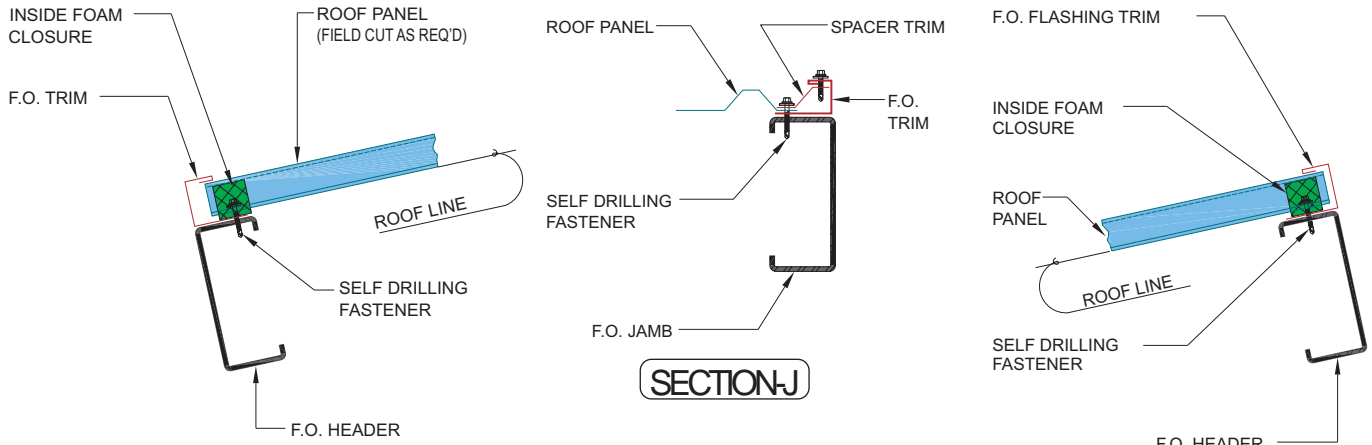

NOTE:  
IT IS THE RESPONSIBILITY OF THE CUSTOMER TO PROVIDE FLASHING FOR ROOF PANELS IN ORDER TO PREVENT DRAINAGE LEAKS, AS ZAMIL STEEL HAS NO INFORMATION ON THE CONNECTION DETAILS OF THE EQUIPMENT ON TOP OF THE FRAMED OPENING IN THE ROOF.

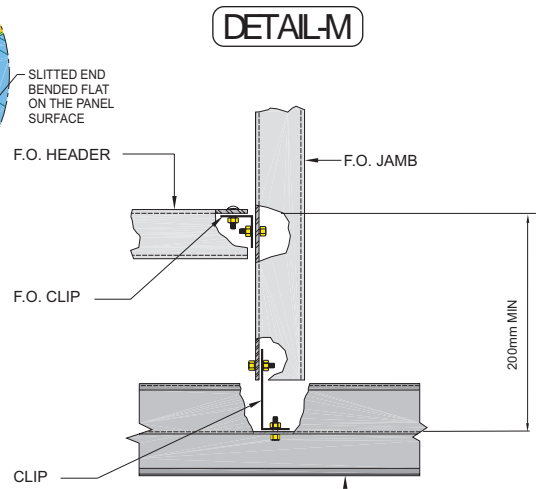
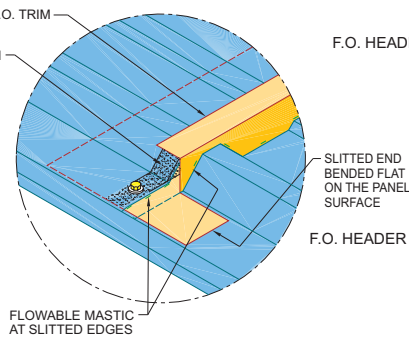
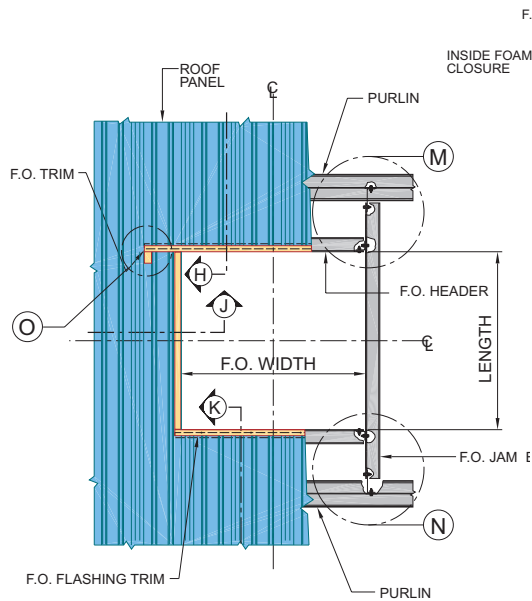
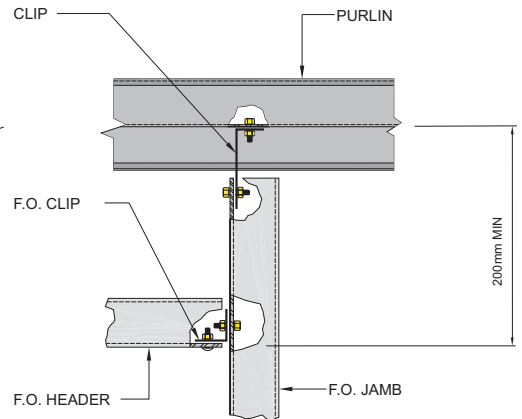
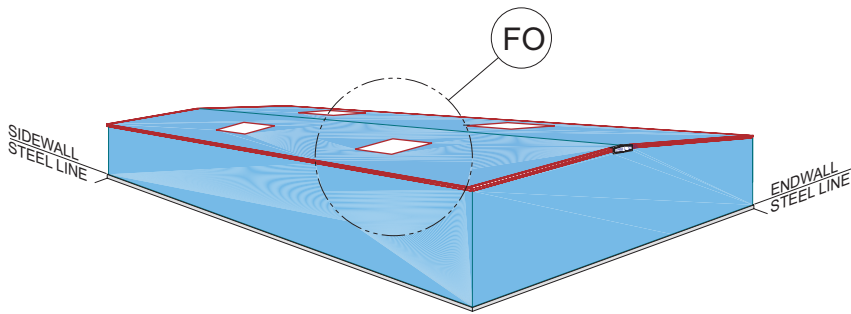

ELEVATION: FRAMED OPENING IN ROOF BETWEEN PURLINS



### 13.7.1 General (Page 1 of 4)

The primary purpose of ventilation is the control of the interior environment of the building by the removal/reduction of:

- *Heat buildup* thus providing comfort for workers, preserving goods and enabling equipment to function properly.
- *Gaseous by-products* (the result of some manufacturing processes) thus providing a healthier atmosphere for workers.
- *Flammable fumes* thus minimizing fire hazards (ventilation is also important after a fire has started at which time it helps in removing the fumes and smoke), and improving visibility for escapees and fire fighters.

Ventilation must not be confused with air conditioning. Ventilation, whether natural or forced, does not have heat reduction characteristics. If a cooler temperature is desired ventilation alone will not suffice and air conditioning must be considered.

Ventilation equipment comes in two categories: Inlet equipment and outlet equipment. Either one can be natural or forced (power).

The planning and correct distribution of ventilation equipment has a major role in the overall efficiency of the ventilation system. Ventilation efficiency is also affected by the location of equipment, partitions and doors inside a building.

A detailed study of ventilation must be made at the planning stage of the building. For complex buildings, determining ventilation requirements may require vast calculations and computer modeling. Much simpler procedures normally suffice for typical pre-engineered buildings.

There are two simple and practical methods for determining ventilation requirements:

- The *Air Change Method*, which is based on a recommended rate of air changes per hour for different building usages when ventilator capacity is given.
- The *Heat Removal Method*, which calculates the volume of air required to remove the heat gain inside a building.

These methods are good tools to approximate the ventilation requirements of the building. More detailed and accurate ventilation plans should be sought by contracting ventilation specialists directly.

13.7.1 General (Page 2 of 4)

**Ventilation Design Using Air Change Method**

$$Q_v = \frac{V \times N}{R \times 3600} \text{ where,}$$

- $Q_v$  = Quantity of ventilators.
- $R$  = Exhaust capacity (m<sup>3</sup>/s).
- $V$  = Building volume (m<sup>3</sup>).
- $N$  = Air change per hour.

In Table 1 below, enter the *stack height*, which is the average of the eave height and the ridge (peak) height. Enter the *temperature difference* between

the inside and outside of the building. Read the equivalent required total *exhaust* capacity in m<sup>3</sup>/s.

The number of recommended air changes per hour is obtained from Table 2.

Finally, apply the aforementioned equation to determine the number of required ventilators. For efficient functioning of the ventilation system the free inlet area (permanent openings plus the effective area of the louvers) must be greater than 150% of the ventilation area.

**Table 1**

Stack Height (m)	Temperature Difference (°C)	R = Exhaust Capacity (m <sup>3</sup> /s)	
		ZRV 300	ZRV 600
3	5	0.779	1.559
6	5	0.916	1.832
	10	1.109	2.218
9	5	1.021	2.041
	10	1.257	2.514
	15	1.438	2.876
12	10	1.382	2.763
	15	1.591	3.182
15	10	1.492	2.983
	15	1.726	3.452

**Table 2**

Type of Building	N = Recommended Air Changes Per Hour	
	From	To
Warehouses, factories, dining rooms, machine shops, engine rooms, textile mills, wood working shops	5	10
Boiler rooms, paint shops, garages, schools	10	15
Buildings with fumes, kitchens, paper mills, textile mills, dye houses	15	20



13.7.1 General (Page 3 of 4)

**Ventilation Design Using Heat Removal Method**

Calculate the total heat gain (H) in the building:

$$H = H_s + H_l + H_i \quad \text{where,}$$

$H_l$  = Heat gain from lighting

$H_i$  = Heat gain from internal equipment, people, etc.

$H_s$  = Solar Heat Gain

$$H_s = A \times I \times a \times e \quad \text{where,}$$

A = Roof Area

I = Actual Solar Radiation striking the roof surface (= 0.945 kW/m<sup>2</sup> for Saudi Arabia)

a = Solar radiation factor of the sheets (= 0.40 for Zamil Steel standard roof sheeting)

e = Proportion of "a" transmitted into the building. This factor is dependent on the "U" value of insulation

= 0.093 for a building with insulation

= 1.000 for a building without insulation

Calculate the ventilation rate required ( $VR_{req'd}$ ):

$$VR_{req'd} = \frac{H}{S_H \times D \times T} \quad \text{where,}$$

$S_H$  = Specific heat capacity of air  
= 1.005

D = Density of air = 1.206 kg/m<sup>3</sup>

T = Temperature difference (use 1/2C difference per meter of stack height).

Determine the quantity of ventilators needed,

$$\text{Quantity of ventilators} = \frac{VR_{req'd}}{R} \quad \text{where,}$$

R = Exhaust capacity in m<sup>3</sup>/s of all ventilators (see page 2 of 13 of this section)

Calculate the total area of gravity ventilators:

Total ventilator area =

$$\frac{VR_{req'd}}{[0.03 \times \text{stack height} \times T]^{1/2}}$$

For special ventilators, the supplier's catalogue must be consulted.

13.7.1 General (Page 4 of 4)

**Example of Ventilation Design using the Air Change Method**

A Clear Span (CS) building that is used as a factory requires ventilation using gravity ridge ventilators. The building is 140 m long and 36 m wide. The eave height is 9 m. The roof has a 0.5/10 slope.

The temperature difference between the inside and outside of the building is not expected to exceed 10½C. Determine the number and size of gravity ventilators that are needed.

<ul style="list-style-type: none"> <li>Stack height = 9.45 m</li> </ul>	The average of the eave height and the ridge height.
<ul style="list-style-type: none"> <li>R (for ZRV 300) = 1.276 m<sup>3</sup>/s</li> <li>R (for ZRV 600) = 2.551 m<sup>3</sup>/s</li> </ul>	Exhaust capacity (R), at 9.45 m stack height, is determined by interpolation from the table on page 2 of 13 of this <b>section</b> .
<ul style="list-style-type: none"> <li>N = 8</li> </ul>	The recommended number of air changes per hour (N) for factories is 5 to 10 times.
<ul style="list-style-type: none"> <li>V = 140 x 96 x 9.45 = 47,628 m<sup>3</sup></li> </ul>	Volume of building.
<ul style="list-style-type: none"> <li><math>Q_v = \frac{47628 \times 10}{1.276 \times 3600} = 82.95</math></li> </ul>	Quantity of ZRV 300 ventilators required. Need 83 (ZRV 300) ridge ventilators.
<ul style="list-style-type: none"> <li><math>Q_{max} = \frac{140 - 1}{3} = 46.33</math></li> </ul>	The maximum number of ridge ventilators (Q <sub>max</sub> ) that the building can accommodate.  $Q_{max} = \frac{\text{Building length (m)} - 1}{\text{Ventilator length (m)}}$
<ul style="list-style-type: none"> <li>Q<sub>max</sub> = 46 ventilators &lt; Q<sub>v</sub> = 83</li> </ul>	ZRV 300 cannot be used. Try ZRV 600
<ul style="list-style-type: none"> <li><math>Q_v = \frac{47628 \times 10}{2.551 \times 3600} = 41.49</math></li> </ul>	Quantity of ZRV 600 ventilators required. Q <sub>v</sub> < Q <sub>max</sub> = 46
<ul style="list-style-type: none"> <li>Use 42 gravity ridge ventilators (ZRV 600) for the building.</li> </ul>	

**13.7.2 Gravity Ventilators (Page 1 of 6)**

Zamil Steel ridge ventilators will provide natural air circulation in any Zamil Steel building.

Ridge ventilators for Zamil Steel pre-engineered buildings shall be ZRV 300 or ZRV 600 and can be installed as continuous or single units. They are 3000 mm long units with fixed throat openings for gravity air flow.

Ridge ventilators are designed for mounting to the building ridge using gravity flow to exhaust heat, fumes, and smoke at rapid rates and regulate free air within the building. Adequate air inflow must be provided to ensure proper ventilation.



Specifications for Gravity Ridge Ventilators		
Type	ZRV 300	ZRV 600
Main Parts	Wind bands, top plate, throat flashing, end flashing, (all 0.5 mm pre-painted galvanized steel)	
Structure	Wind band (cold-formed plain sheet) with brace plates (0.5 mm pre-painted) and throat gussets (1.3 mm galvanized)	Wind band (cold-formed Profile 'C' panel) with framing*, that consist of cold-formed channels and hot rolled angles
Length	3000 mm	
Installation	At ridge, continuous units or single units	
Throat	300 mm	600 mm
Throat Area	0.9 m <sup>2</sup>	1.8 m <sup>2</sup>
Throat Opening	Fixed	
Damper	Option available	Option not available
Bird Screen	1.06 mm galvanized 12 mm x 12 mm mesh	2.3 mm galvanized 16 mm x 16 mm mesh
Finish	Frost White color, but also available in other Zamil Steel standard colors upon request	

\* For ZRV 600 ridge ventilators, three ventilator frames shall be used as support. Ventilator frames are shot-blast cleaned to SA 2-1/2 and given one coat of shop applied Colturiet Sealer. Each frame shall consist of a cold-rolled channel that is attached between the ridge purlins and a welded framework made of hot rolled angles that are field bolted to the channel.

13.7.2 Gravity Ventilators (Page 2 of 6)

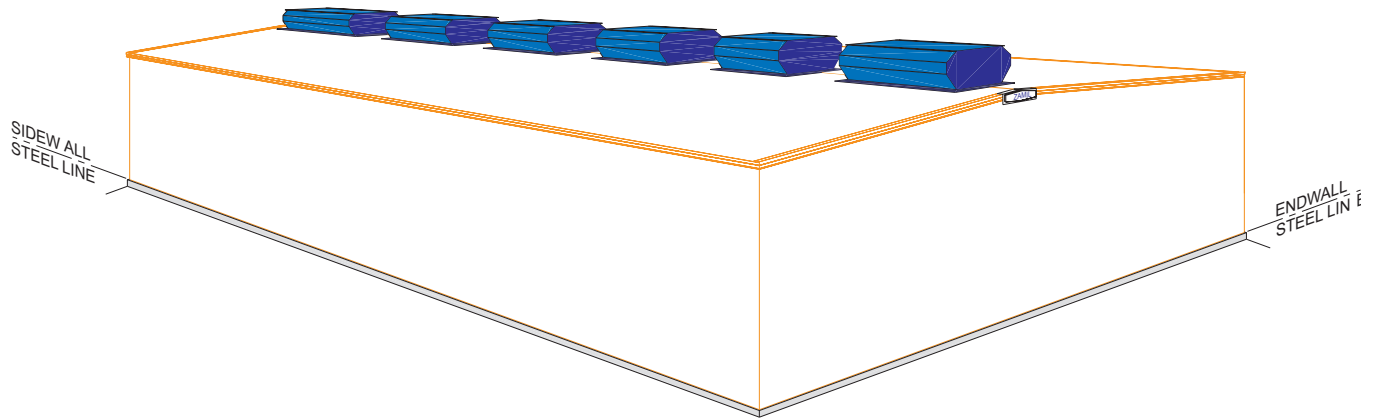

ISOMETRIC : SINGLE RIDGE VENTILATOR INSTALLATION

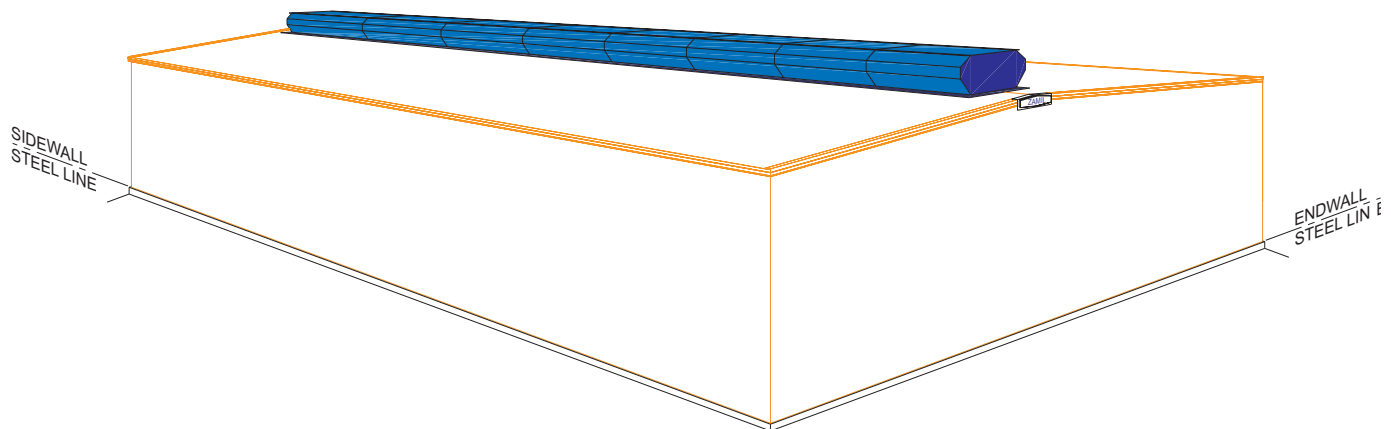

ISOMETRIC : CONTINUOUS RIDGE VENTILATOR INSTALLATION

13.7.2 Gravity Ventilators (Page 3 of 6)

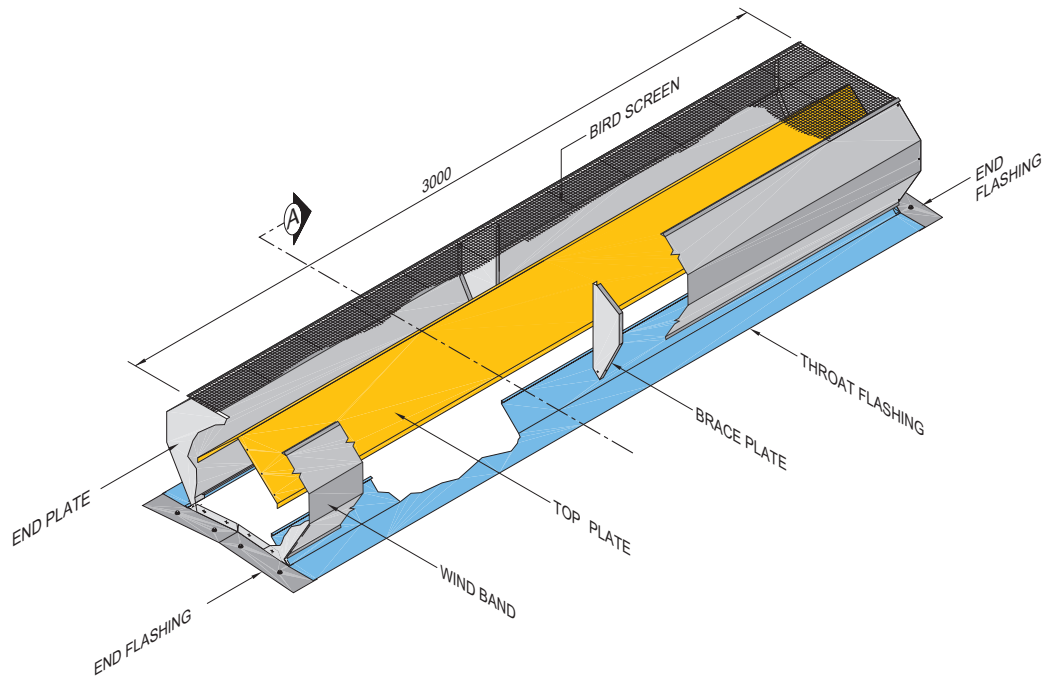

**DETAIL** : SINGLE 300mm RIDGE VENTILATOR WITHOUT DAMPER

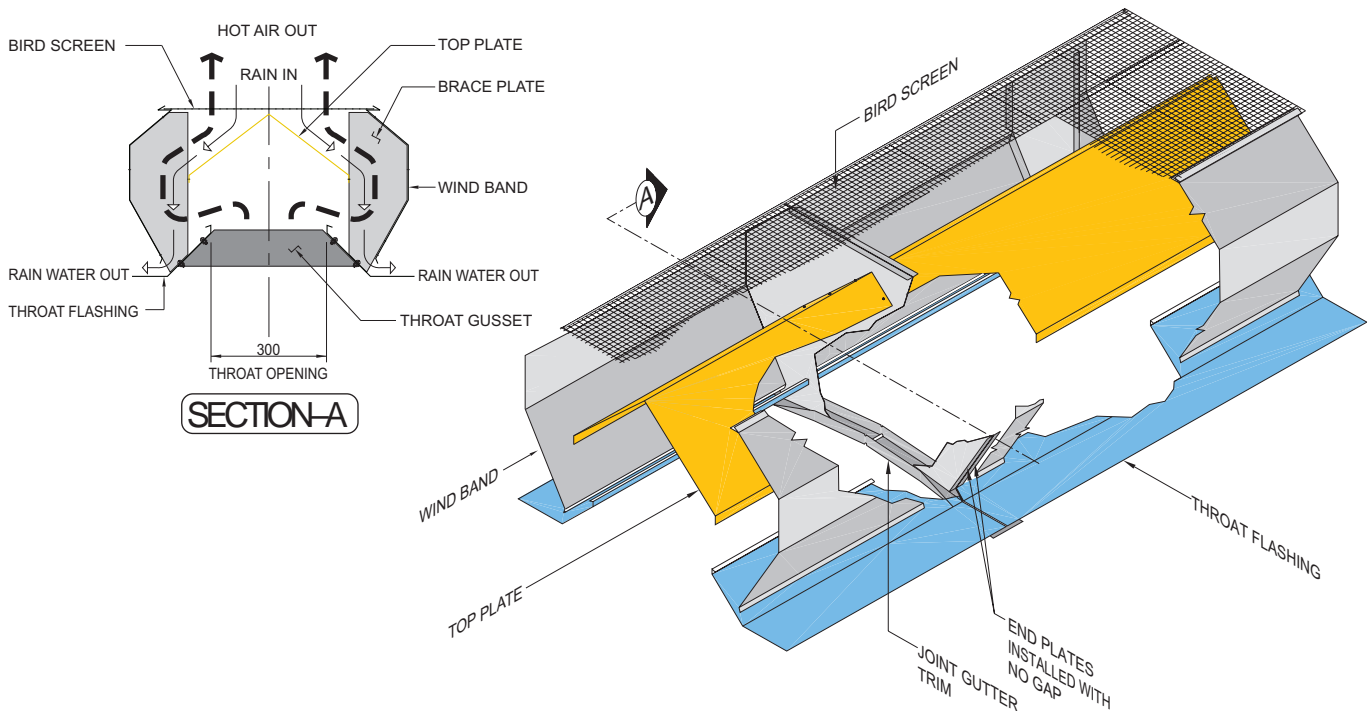

**DETAIL** : END PLATES CONNECTION AT CONTINUOUS RIDGE VENTILATOR

13.7.2 Gravity Ventilators (Page 4 of 6)

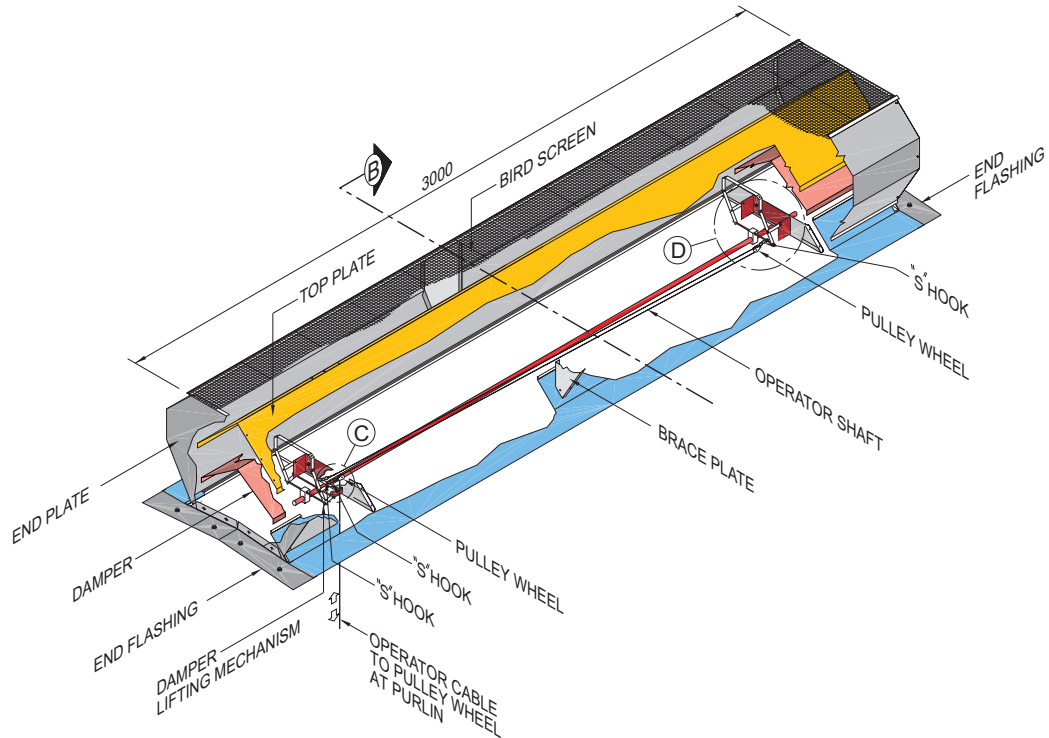

**DETAIL** : SINGLE 300 mm RIDGE VENTILATOR WITH DAMPER

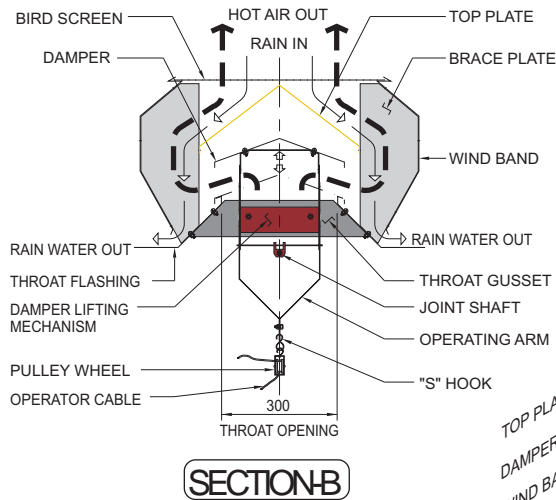

**SECTION B**

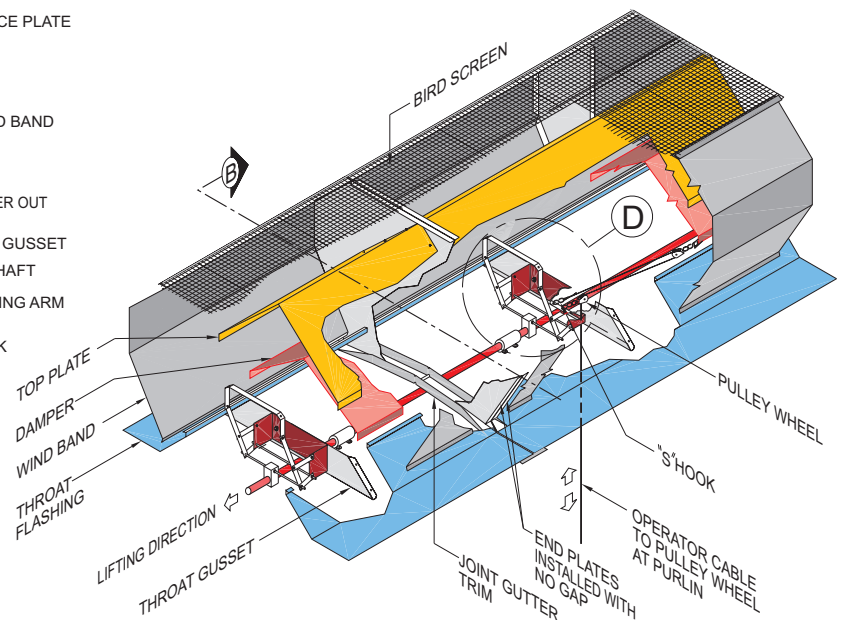

**DETAIL** : END PLATES CONNECTION AT CONTINUOUS RIDGE VENTILATOR



13.7.2 Gravity Ventilators (Page 5 of 6)

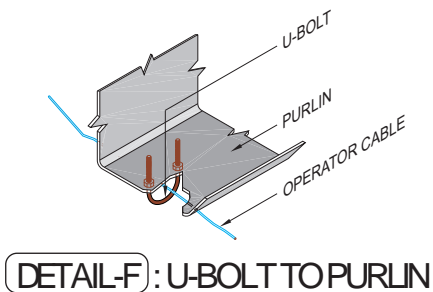
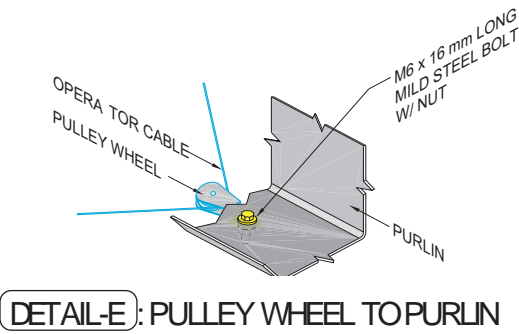
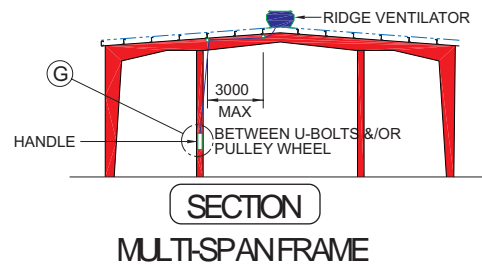
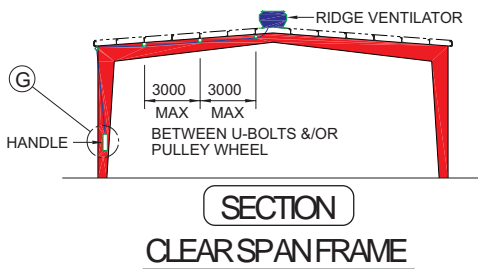
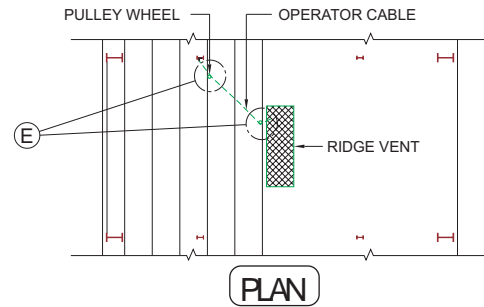
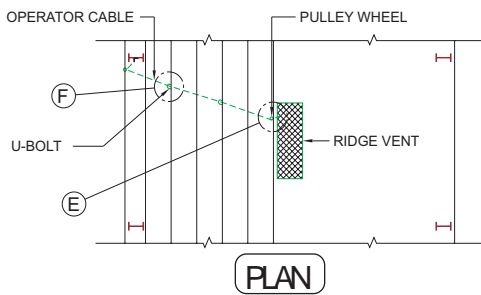
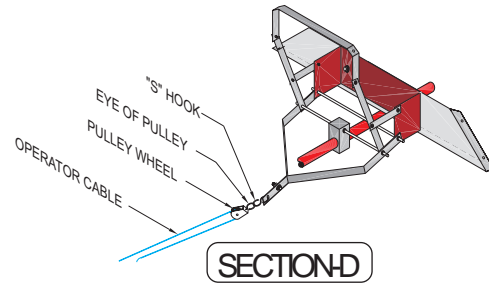
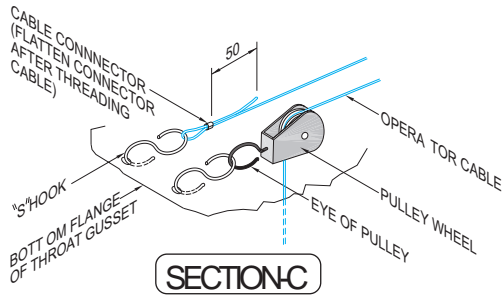

NOTE:  
FOR ENDWALL COLUMN, THE HANDLE SHALL BE ATTACHED TO A BUILT-UP COLD-FORMED COLUMN.

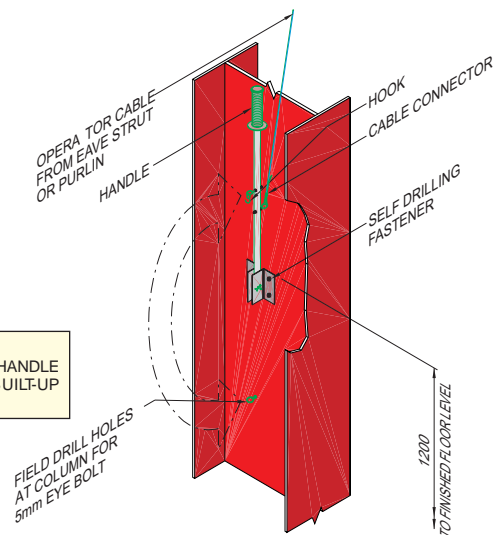

RIDGE VENTILATOR DAMPER AND OPERATOR CABLE INSTALLATION

13.7.2 Gravity Ventilators (Page 6 of 6)

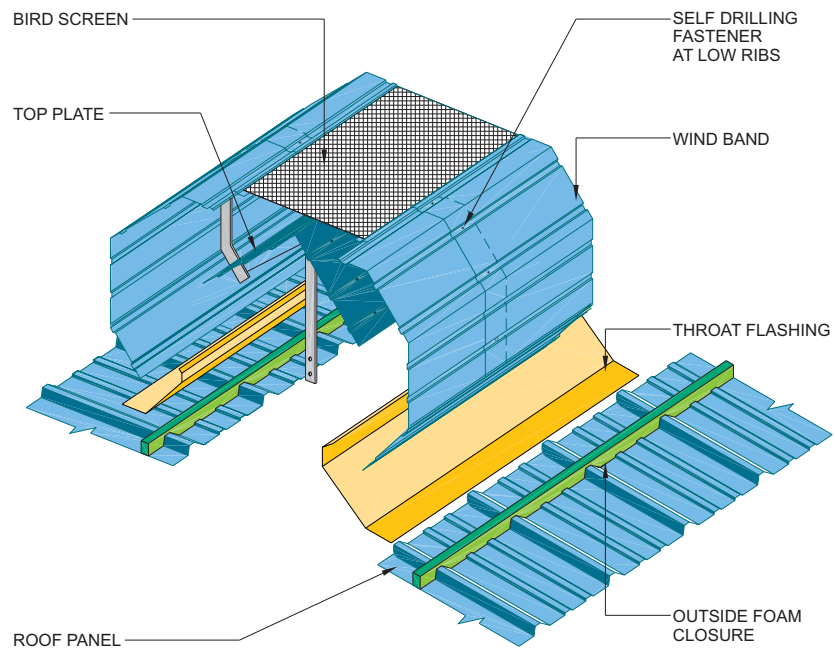
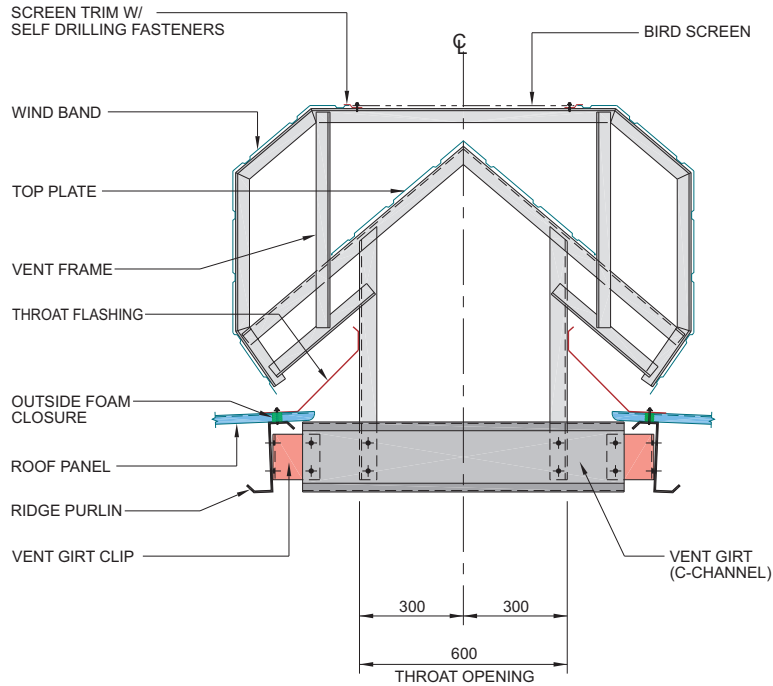

**DETAILS** : 600mm THROAT RIDGE VENTILATOR (SINGLE OR CONTINUOUS)

**13.7.3 Power Ventilators (Page 1 of 3)**

Power ventilators consist of a one-piece aluminum base and throat assembly complete with spun aluminum non-return shutters incorporating an anti-dust/sand seal.

Power is supplied by means of a direct drive motor with an integral aluminum aerofoil blade impeller, statically and dynamically balanced as a complete unit. The motor and impeller are fitted with guards for protection against moving parts. Noise level does not exceed 66 dB(A) at a distance of 2.0 m. The unit is weatherproof against rain and dust, considering a maximum rainfall of 75 mm/h and wind speed of 130 km/h. The power unit is fitted with a non return shutter, which closes when the unit is not in operation and is held in position by a centrifugal locking mechanism.

Recommended free air inlet area to be at least 2.5 m<sup>2</sup> per fan.

Ventilation design using the Heat Removal Method is as illustrated in page 3 of 13 of **section 13.7**.

For special ventilators, the supplier's catalogue must be consulted.

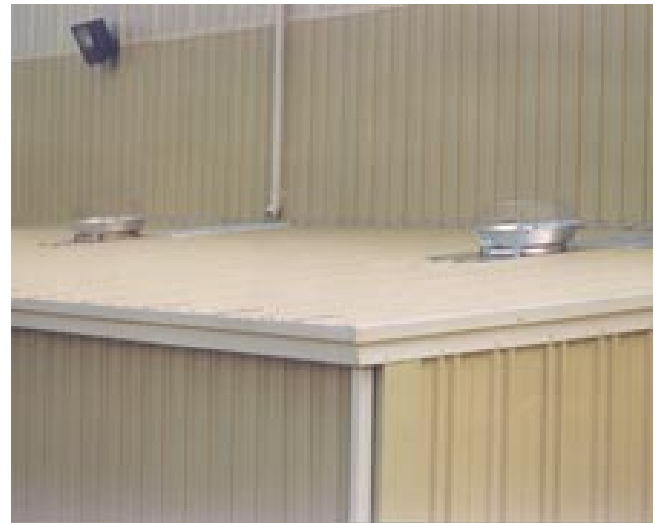

<b>Power Ventilator [Colt Tornado T630] (Weight=32 kg)</b>			
<b>Performance Range Table</b>			
<b>Power Supply</b>			<b>Exhaust Volume (m<sup>3</sup>/sec)</b>
<b>Phase</b>	<b>Frequency (Hz)</b>	<b>Voltage (V)</b>	
3	50	415	2.4
	60	380	2.6

13.7.3 Power Ventilators (Page 2 of 3)

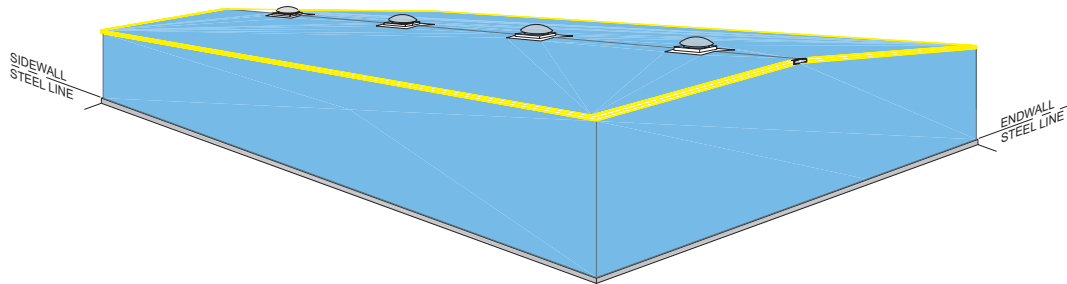

**ISOMETRIC** : POWER VENTILATOR INSTALLATION AT ROOF RIDGE

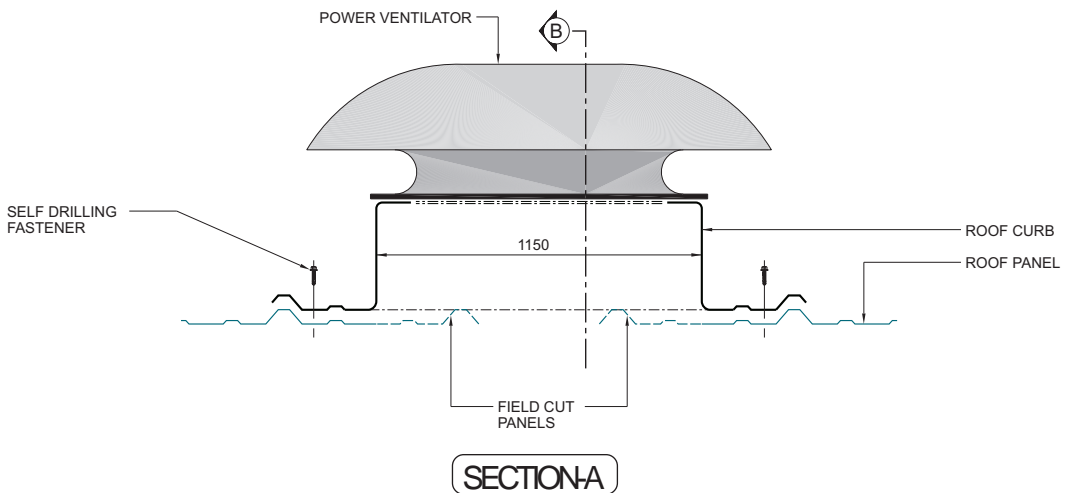
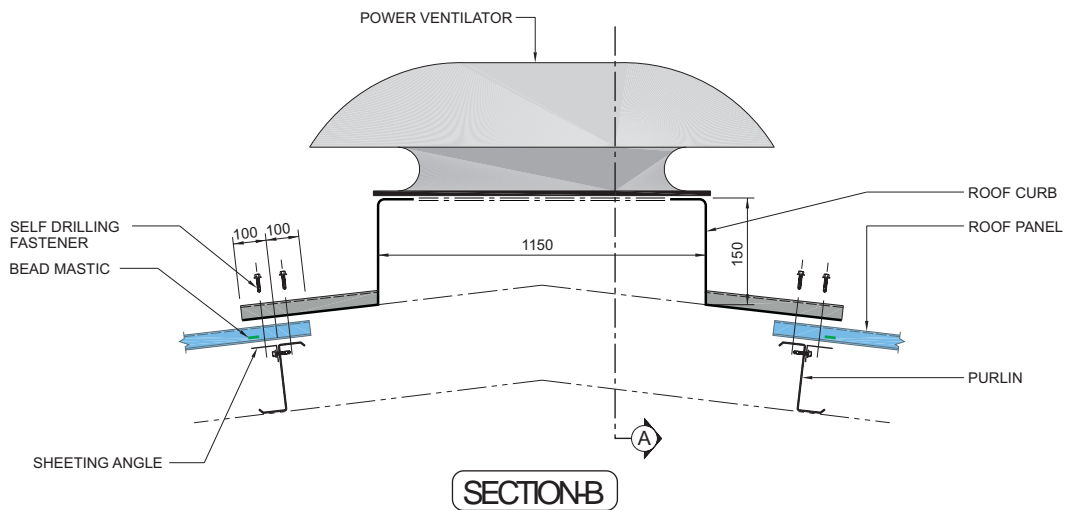

**DETAILS** : POWER VENTILATOR AT ROOF RIDGE

13.7.3 Power Ventilators (Page 3 of 3)

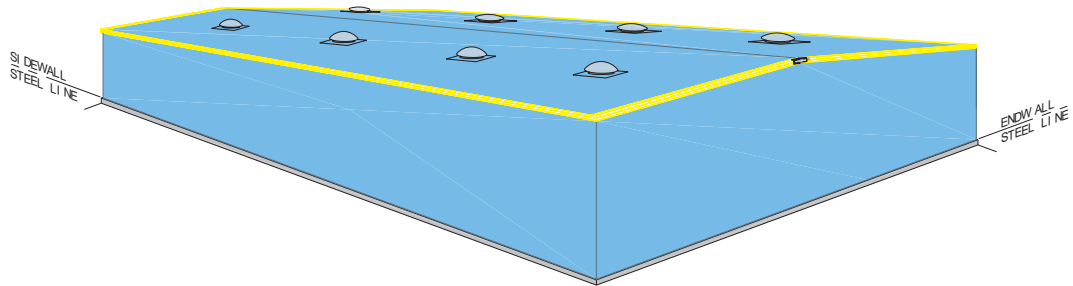

**ISOMETRIC** : POWER VENTILATOR INSTALLATION AT ROOF SLOPE

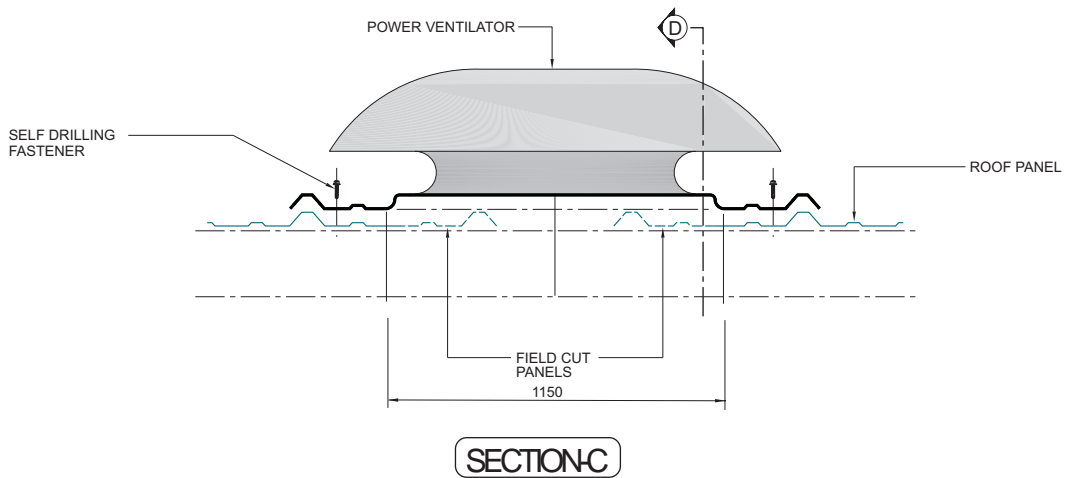
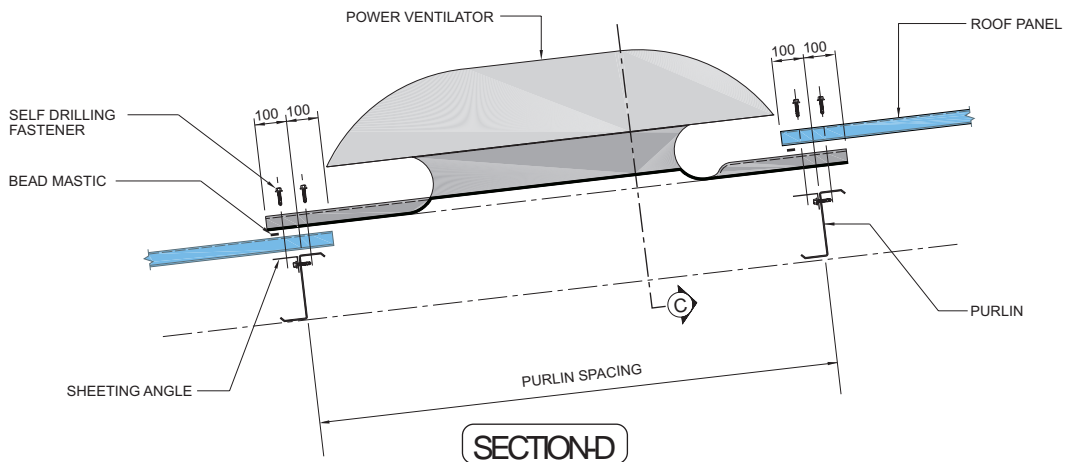

**DETAILS** : POWER VENTILATOR AT ROOF SLOPE

13.8.1 General (Page 1 of 2)

Zamil Steel **louvers** are used to provide natural air flow into a building. There are two standard types of louvers that are supplied by Zamil Steel: **fixed louvers** and **adjustable louvers**.

Louvers are generally used in industrial and storage buildings. They form a part of the ventilation system that is often required to reduce buildup of dust, vapor and heat inside buildings to practical levels. The use of louvers, suitably positioned in the perimeter walls of a building, in combination with roof ventilators provides continuous circulation of natural air and creates a healthier atmosphere for the building occupants.

The total effective area of louvers is equal to the free inlet area of the building minus the area of permanent opening.

The free inlet area of a building is equal to 1.50 x ventilation area.

The following equation is used to determine the effective inlet area of one louver.

$$A_{EFF} = N \times C \times L \text{ where,}$$

- N = Number of openings in louver.
- C = Opening depth between blades(m).
- L = Opening length (m).

Note that when using an insect screen, the effective inlet area ( $A_{EFF}$ ) of the louver should be further reduced by 50%.

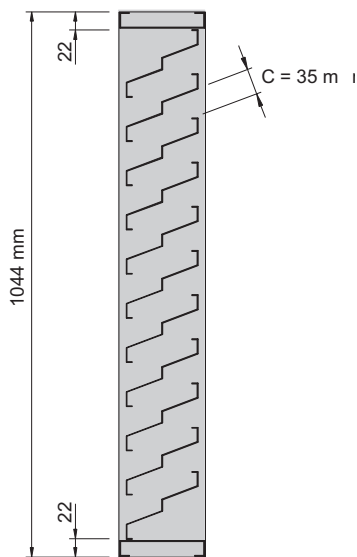

SECTION-A

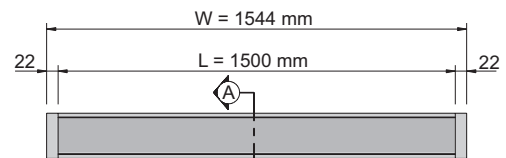

PLAN



**13.8.1 General (Page 2 of 2)**

Using the same building example in **section 13.7**, page 4 of 13.

A Clear Span (CS) building that is used as a factory requires ventilation using gravity ridge ventilators.

The building is 140 m long and 36 m wide. The eave height is 9 m and the roof has a 0.5/10 slope. The building required 46 nos. ZRV 600 gravity ridge ventilators and has two permanent wall openings, each 4 m wide x 5 m high. Find the number of fixed louvers needed to provide proper air circulation.

<ul style="list-style-type: none"> <li>• Ventilation area = 82.8 m<sup>2</sup></li> </ul>	Ventilation area = Throat Width x Ventilator Length x No of Ventilators = 0.6 x 3 x 46.
<ul style="list-style-type: none"> <li>• Required free inlet area = 124.2 m<sup>2</sup></li> </ul>	Required free inlet area = 1.5 x Ventilation Area = 1.5 x 82.8
<ul style="list-style-type: none"> <li>• Effective area of louvers = 84.2 m<sup>2</sup></li> </ul>	Effective area of louvers = Free inlet area - area of permanent openings = 124.2 m <sup>2</sup> - 2 x (4 x 5)m <sup>2</sup> .
<ul style="list-style-type: none"> <li>• A<sub>EFF</sub> = 0.525 m<sup>2</sup></li> </ul>	Calculating the effective inlet area of a standard Zamil Steel fixed louver: N = 10 openings, C = 0.035 m and L = 1.0 m  $A_{EFF} = N \times C \times L$ $= 10 \times 0.035 \times 1.5$
<ul style="list-style-type: none"> <li>• Total no. of louvers required = 161</li> </ul>	Total no. of louvers required = 84.2/0.525
<ul style="list-style-type: none"> <li>• Use 162 fixed louvers (1.0 mx1.5 m) 81 louvers on each sidewall.</li> </ul>	

### 13.8.2 Fixed Louvers (Page 1 of 3)

Fixed louvers are made of heavy-duty natural anodized aluminum construction and are specifically designed to fit Zamil Steel's wall panels. The frame, blades and flashing of the fixed louver are made of tempered aluminum alloy extrusions meeting ASTM B 221 Alloy 6063-T6.

The surface of all aluminum extrusions and assemblies are anodized with a minimum anodic coating thickness of 15 microns.

The screen frames are extruded and manufactured from a suitable alloy. They are sufficiently rigid to lie flat against the louver and prevent excessive bending in frame members and sagging in the screen.

The screen and screen spline are made from aluminum or a material compatible with aluminum.

Standard fixed louvers are available in one size only: 1500 mm wide x 1000 mm high.





13.8.2 Fixed Louvers (Page 2 of 3)

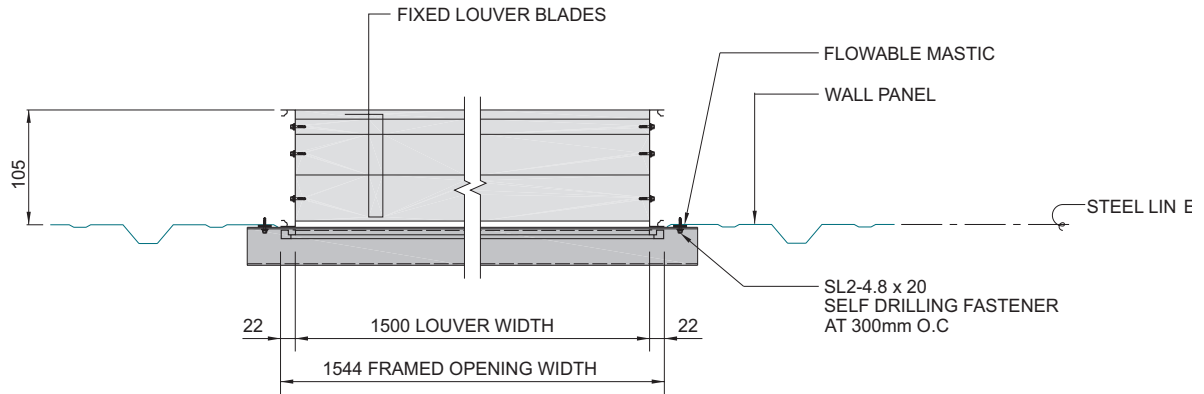

SECTION A

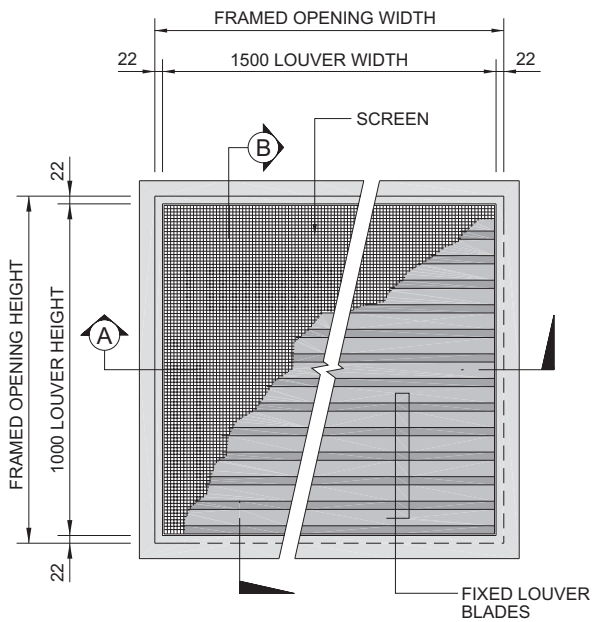

ELEVATION : LOUVER EXTERIOR

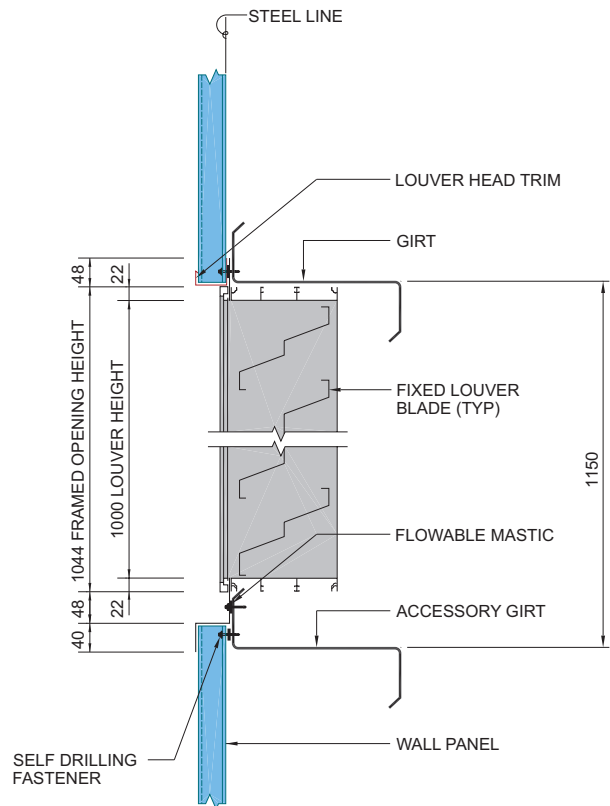

SECTION B

DETAIL : FIXED ALUMINUM LOUVER AT SINGLE SKIN WALL PANEL

13.8.2 Fixed Louvers (Page 3 of 3)

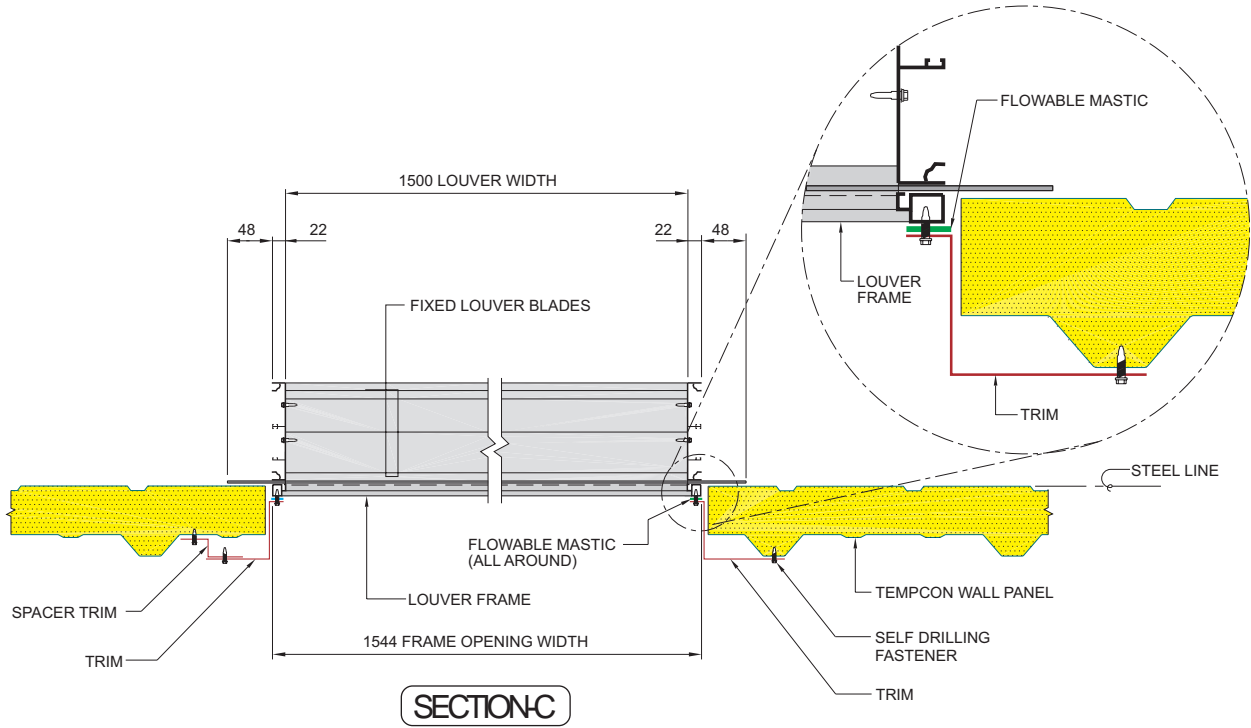

SECTION C

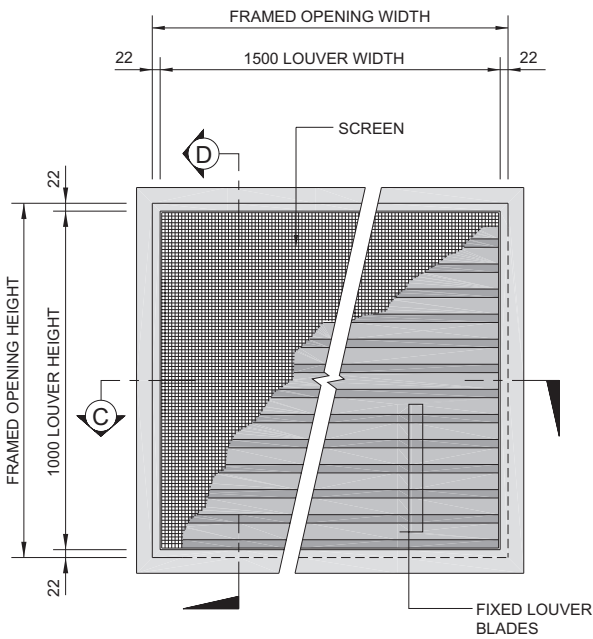

ELEVATION : LOUVER EXTERIOR

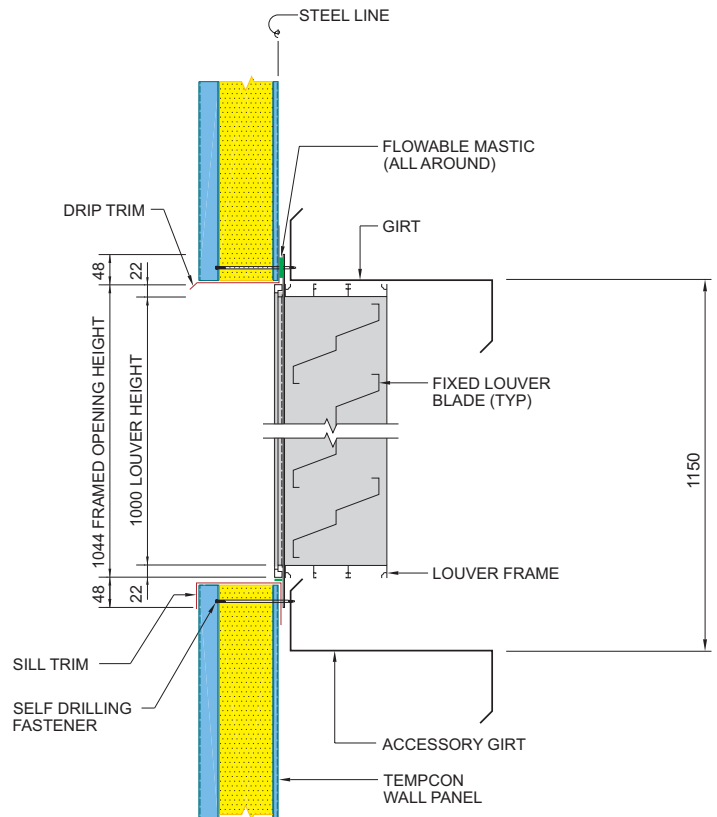

SECTION D

DETAIL : FIXED ALUMINUM LOUVER AT TEMPCON WALL PANEL

### 13.8.3 Adjustable Louvers (Page 1 of 3)

Adjustable louvers are heavy-duty natural anodized aluminum construction and are specially designed for Zamil Steel wall panels. Standard stationary and adjustable louvers are available for all Zamil Steel buildings. The frame, blades and flashing of the adjustable louvers are tempered aluminum alloy extrusions conforming to ASTM B 221 Alloy 6063-T6.

Pivot clips are made of hardened aluminum to hold the blades tight.

Adjustable louvers are equipped with a lever to open (full), close (tight), or set at any position in between.

The louver blades operate in unison and form a tight closure. The operating mechanism should be fully lubricated during assembly. All louver blades have weather strips and, in the closed position, form a weather tight seal.

The surface of all aluminum extrusions and assemblies are anodized with a minimum anodic coating thickness of 15 microns.

The screen frames are extruded and manufactured from a suitable alloy. They are sufficiently rigid to lie flat against the louver and prevent excessive bending in frame members and sagging in screening.

The screen and screen spline are from aluminum or a material compatible with aluminum.

Standard adjustable louvers are available in one size: 900 mm wide x 1000 mm high



13.8.3 Adjustable Louvers (Page 2 of 3)

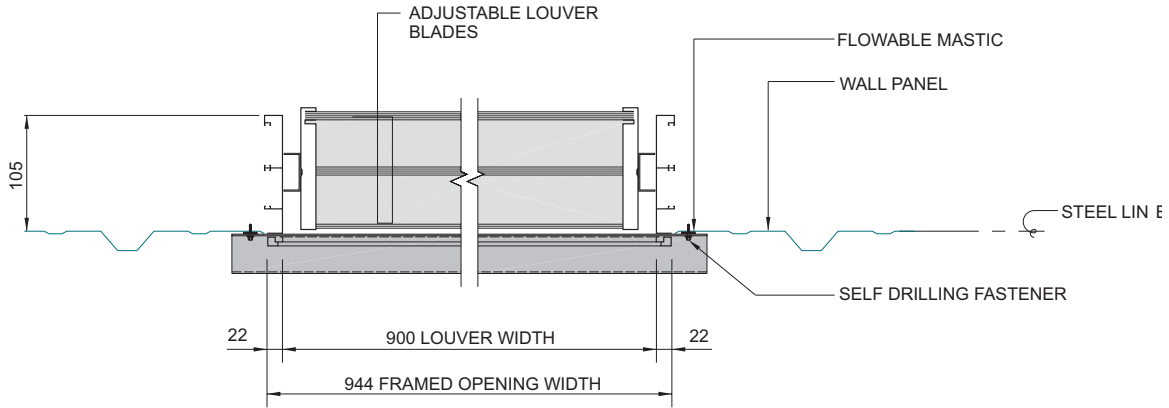

SECTION-A

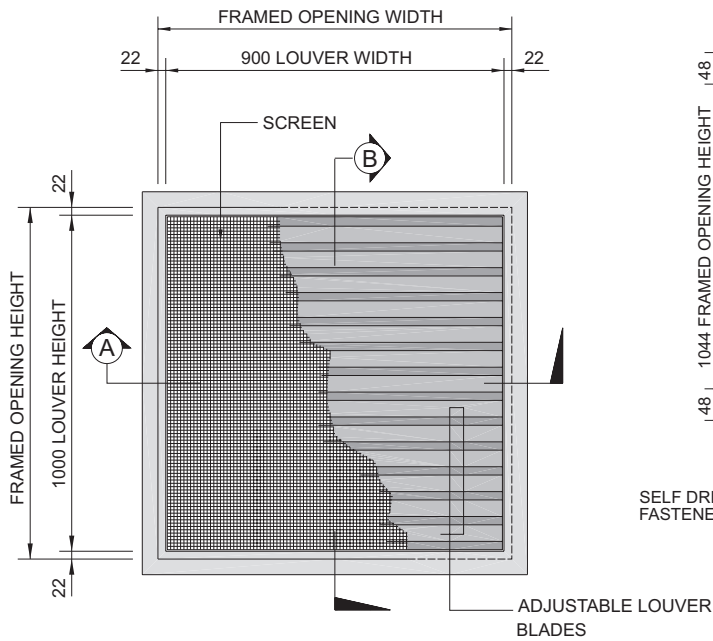

ELEVATION: LOUVER EXTERIOR

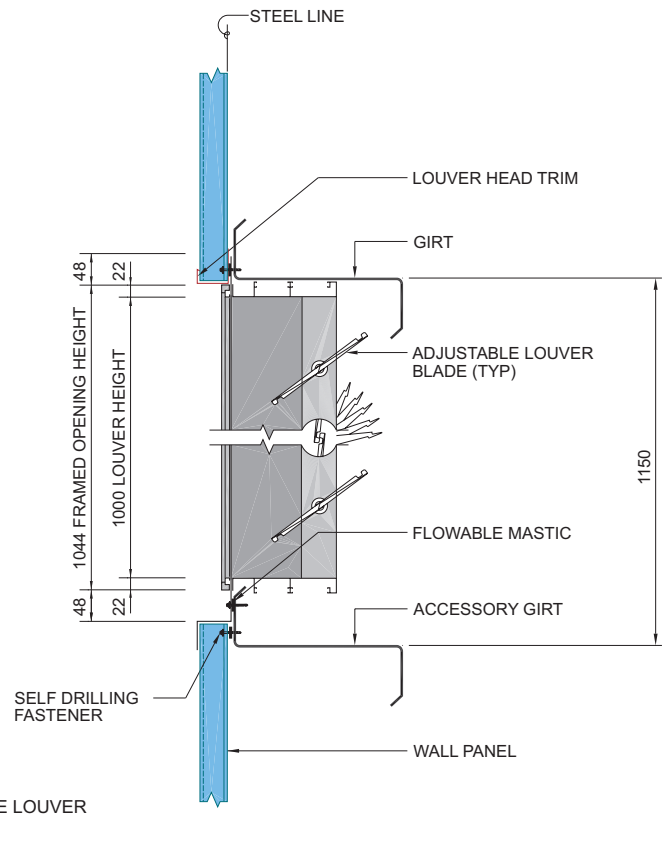

SECTION-B

DETAIL : ADJUSTABLE ALUMINUM LOUVER AT SINGLE SKIN WALL PANEL

13.8.3 Adjustable Louvers (Page 3 of 3)

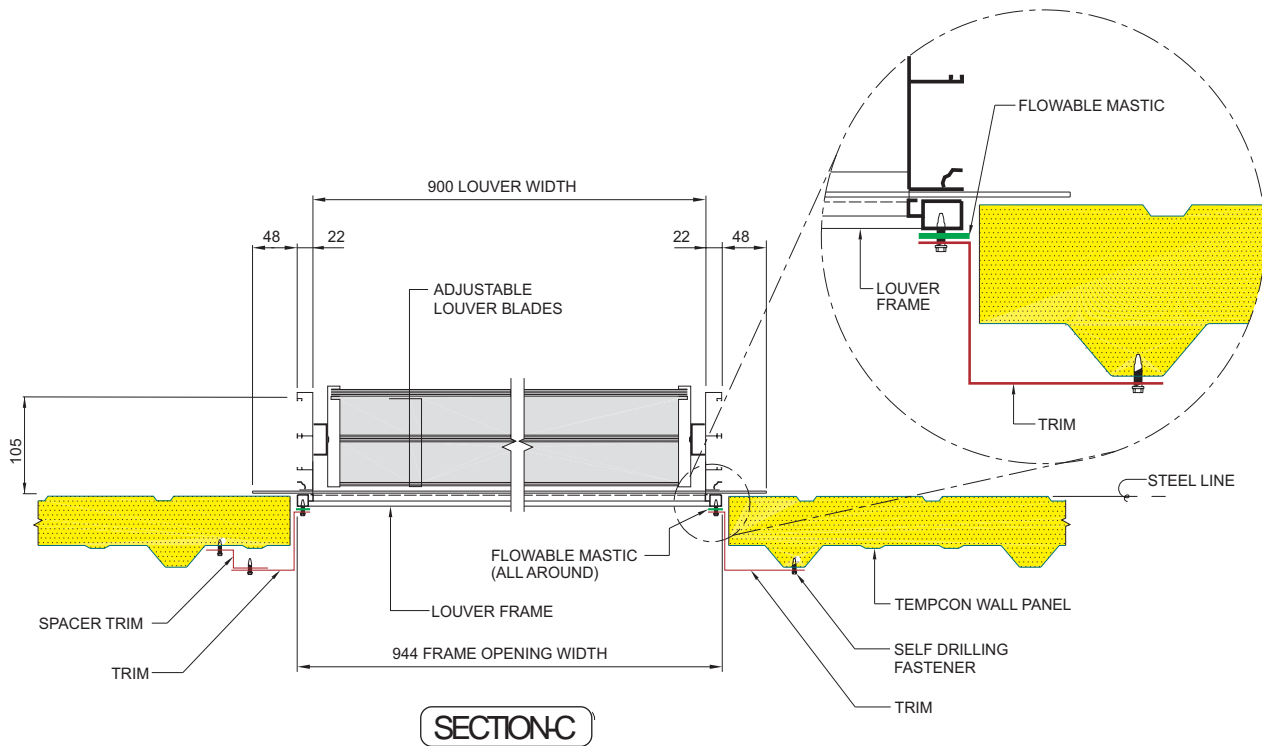

SECTION-C

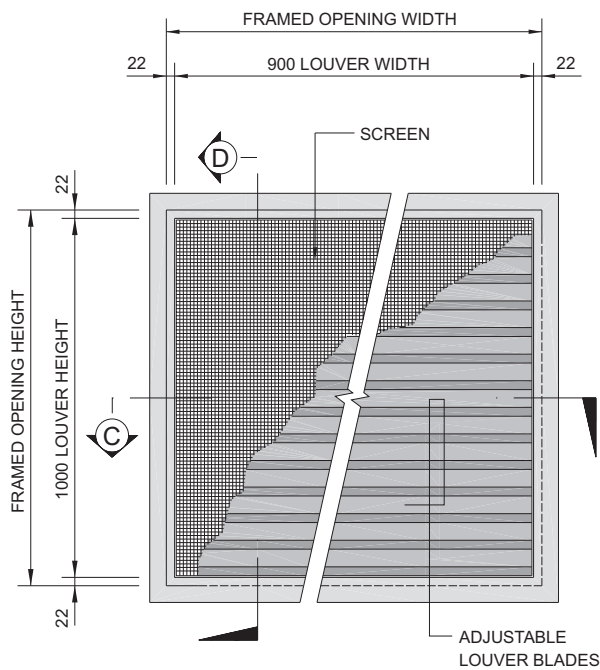

ELEVATION: LOUVER EXTERIOR

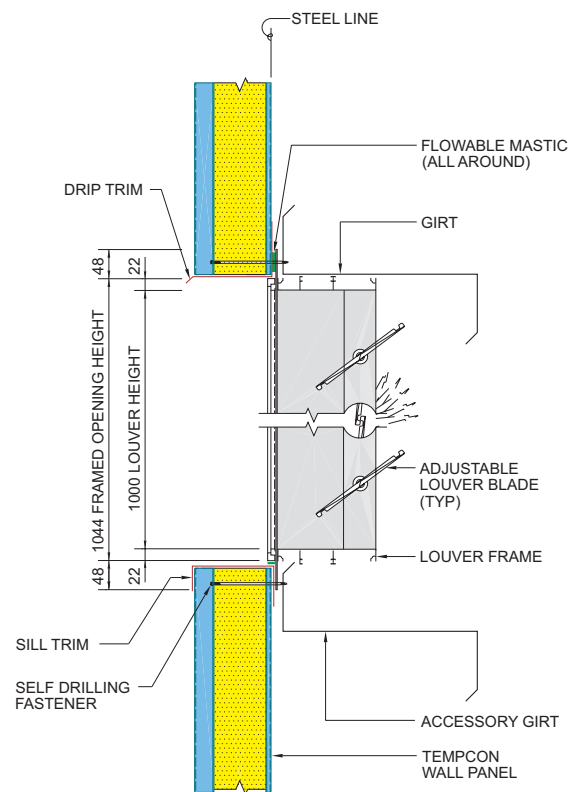

SECTION-D

DETAIL : ADJUSTABLE ALUMINUM LOUVER AT TEMPCON WALL PANEL

Fiberglass **roof curbs** will be provided if "Colt Tornado" power ventilators (Zamil Steel's standard) at the ridge are included in Zamil Steel's scope of supply. Roof curbs are also supplied, if requested by customers, to support roof mounted fans or other equipment.

The fiberglass roof curb base has the same profile as Zamil Steel's standard panel profile thus making installation easy and watertight. Most importantly, the roof curb eliminates the need for intricate metal trims around roof openings, which are normally required to protect against roof leaks.

Roof curbs are made of material that is strong, lightweight, easy to maintain and corrosion resistant. They have a smooth and uniform surface that blends with the building's exterior finish and are supplied in white color only.

The minimum thickness of the roof curb is 3 mm which can be increased to support heavier load.

For very heavy equipment or building accessories, a reinforcement is embedded in between the fiberglass layers to provide extra strength to the roof curb.

It is strongly recommended to provide roof curbs for power vents and fans as they provide a horizontal surface for mounting the fans which in turn results in smoother fan performance.



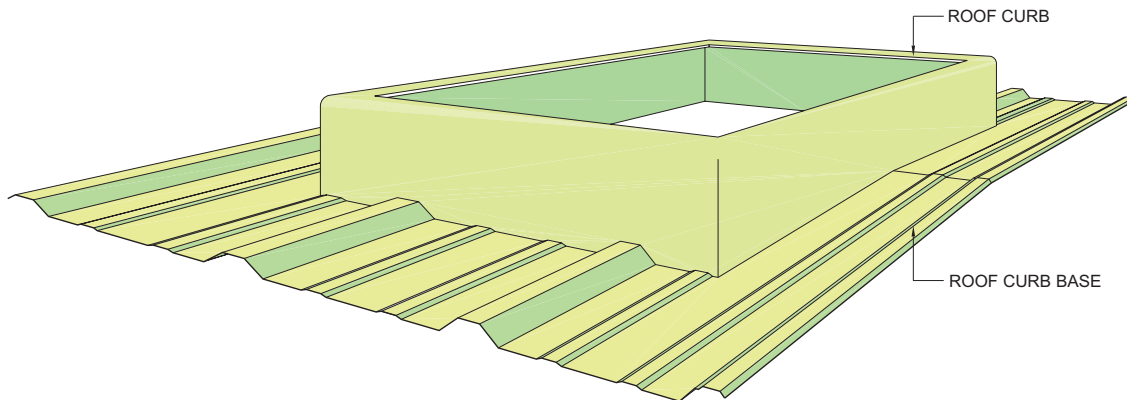

**PERSPECTIVE** : ROOF CURB AT RIDGE

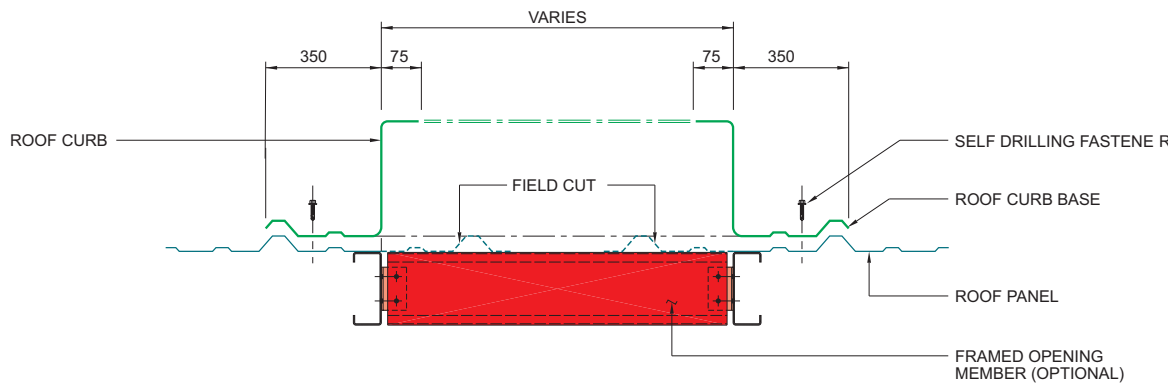
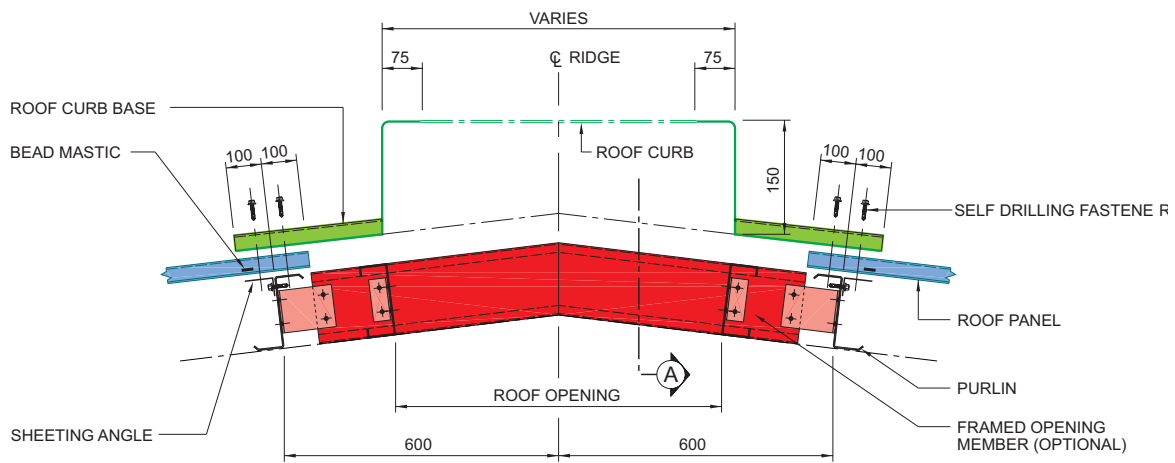

**SECTION A**

**ELEVATION** : ROOF CURB AT RIDGE

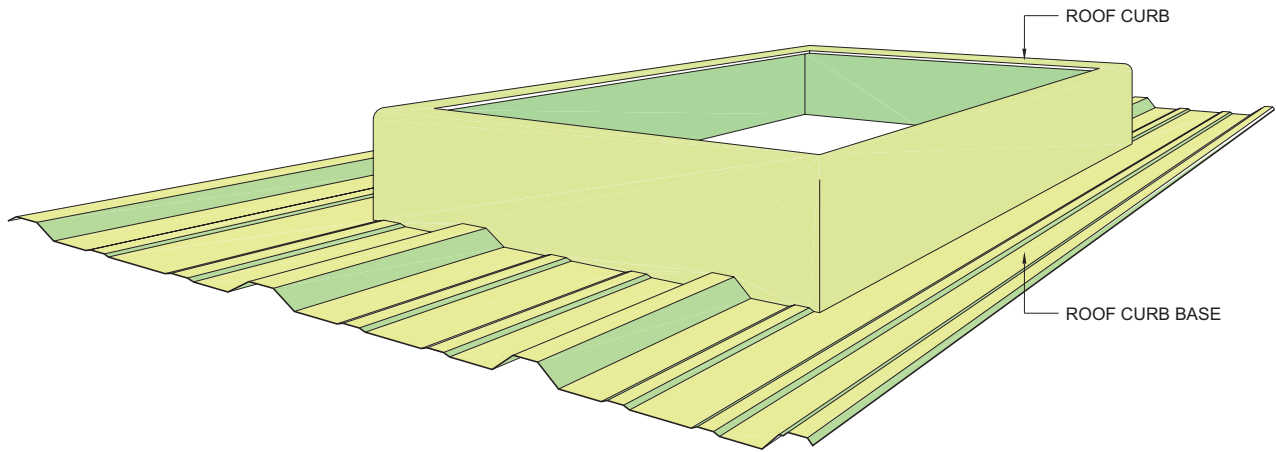

**PERSPECTIVE** : ROOF CURB AT SLOPE

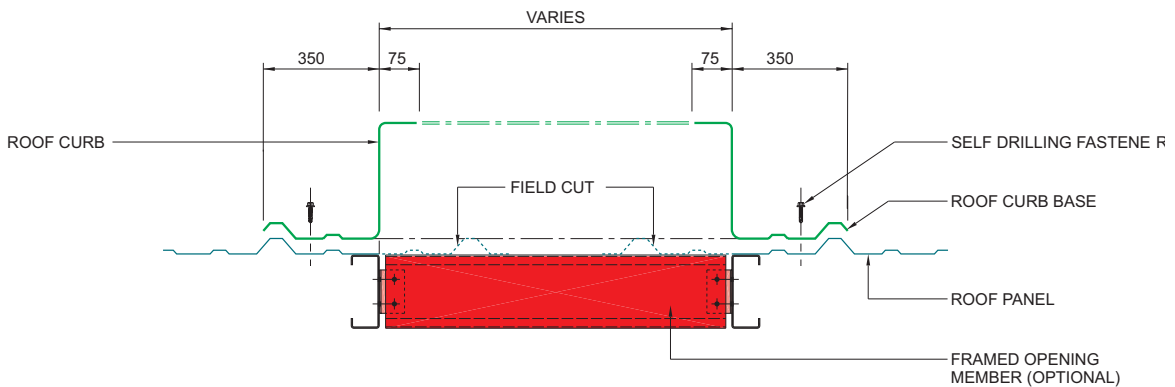
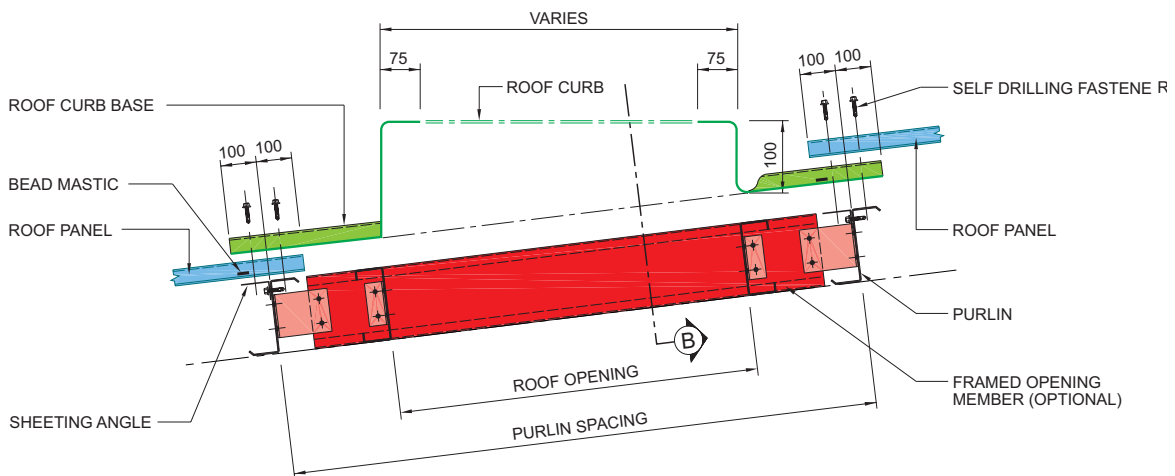

**SECTION B**

**ELEVATION** : ROOF CURB AT SLOPE



Zamil Steel's translucent panels for roof and walls are used to allow natural light into the building and, thus, reduce electrical lighting requirements. Translucent panels are available in the same widths as Zamil Steel's steel panels and are supplied in 3250 mm lengths.

The corrugations of translucent panels match the profile of Zamil Steel's standard panel profiles for the roof and wall and are available in translucent white only.

They are made of white light-stabilized weather-resistant polyester resins mixed with silane-finished split strand fiberglass and weigh 2.4 kg/m<sup>2</sup>.

Fiberglass translucent panels shall have the nominal values as per the table below.

All specimens for testing should be conditioned as per ASTM D618, procedure A.



Fiberglass Translucent Panel Specifications		
Characteristic	Value	Test Method
Light Transmission	80% + 5%	ASTM D1494
Solar Transmission	25% + 5%	ASTM E424
Tensile Strength	10.3 kN/cm <sup>2</sup>	ASTM D638
Compressive Strength	20.7 kN/cm <sup>2</sup>	ASTM D695
Water Absorption Rate	< 0.3%, in 24 h @ 23½C	ASTM D570
Specific Gravity	1.4 @ 23½C (min.)	ASTM D792
Flexural Strength	20.7 kN/cm <sup>2</sup>	ASTM D790
Shear Strength	10.3 kN/cm <sup>2</sup>	ASTM D73
Bearing Strength	13.8 kN/cm <sup>2</sup>	ASTM D953 A
Flammability	> 51 mm/minute*	ASTM D635
Impact Strength	4.27 N.m/cm*	ASTM D256
Thermal Transmittance (U)	4.46 W/m <sup>2</sup> .K	ASTM C236

\* Values vary with thickness

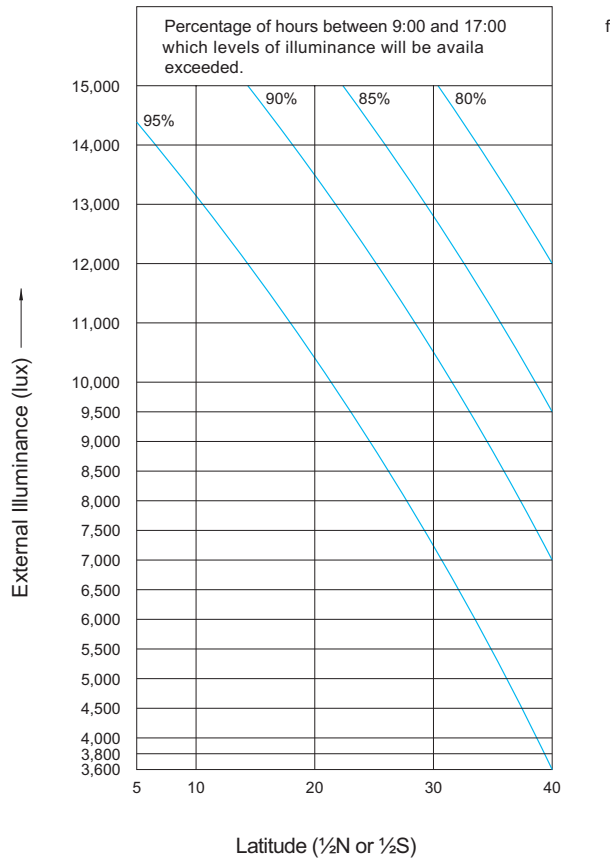

Figure (1) External Illuminance that will be met or exceeded for various percentages of the day between 9:00 AM to 5:00 PM.

**Note:** To ensure that the uniformity of illuminance will not exceed a ratio of 2:1, the distance between the centers of rows (or continuous runs) of skylights and also between the individual skylights in rows should not exceed twice the height of the skylights above the working plane.

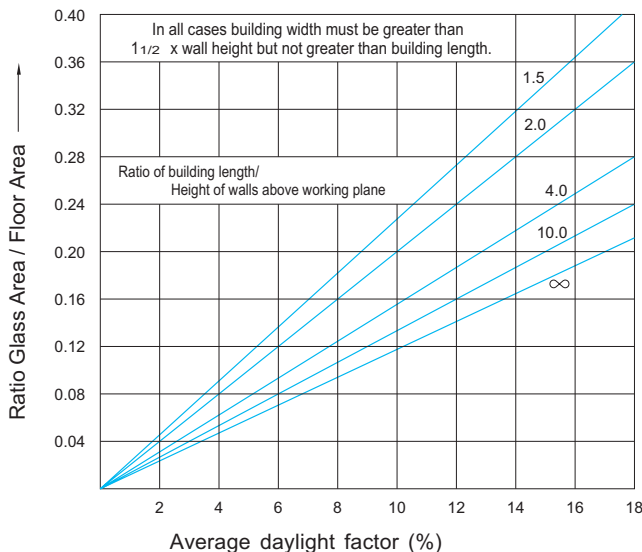

Figure (2) Daylight Factor for Skylight in a Flat Roof

Table (1) Recommended Levels of Illumination

Building Type	Recommended Levels of Illumination (Lux)
<b>AIRCRAFT HANGARS</b>	
Repair Service	1100
Inspection	2200
<b>WAREHOUSES</b>	
Rough, Bulky Material	110
Medium Size Material	220
Fine Size Material	550
<b>GARAGES</b>	
Repair Services	1100
Parking Garages	550
<b>OFFICES</b>	
Fine Operations	2200
Regular Work	1100
<b>FACTORIES</b>	
Inspection	2200
Fine	1100
Medium	550
<b>EXHIBITION HALLS</b>	1100

Table (2) Typical Light Loss Factor for Daylighting Design

Locations	Light loss factor glazing position		
	Vertical	Sloped	Horizontal
Clean areas	0.9	0.8	0.7
Industrial areas	0.8	0.7	0.6
Very Dirty areas	0.7	0.6	0.5

**REFERENCES:**

1. Helms, R.N. and Blecher, M.C., 'Lighting for Energy - Efficient Luminous Environment', Prentice Hall, 1991.
2. Pritchard, D.C., 'Lighting', Longman Scientific and Technical, Fourth Edition, 1990.
3. Illuminating Engineering Society, 'IES Lighting Handbook', Third Edition, 1959.
4. Lynes, J.A., 'Principles of Natural Lighting', Elsevier Publishing Company Ltd., 1968.

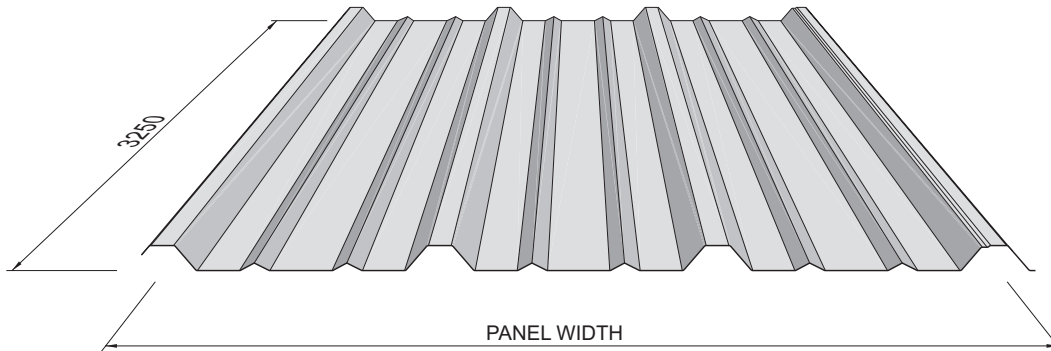

**PERSPECTIVE : TRANSLUCENT PANEL**

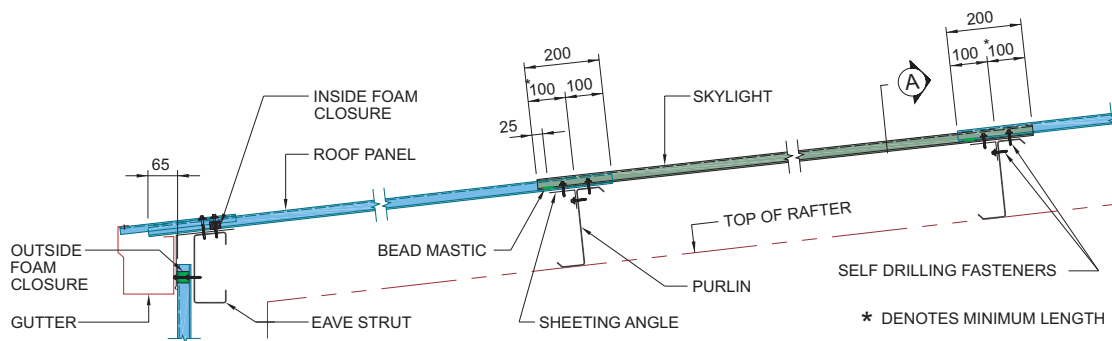

**ELEVATION : TRANSLUCENT PANEL AT ROOF (SKYLIGHT)**

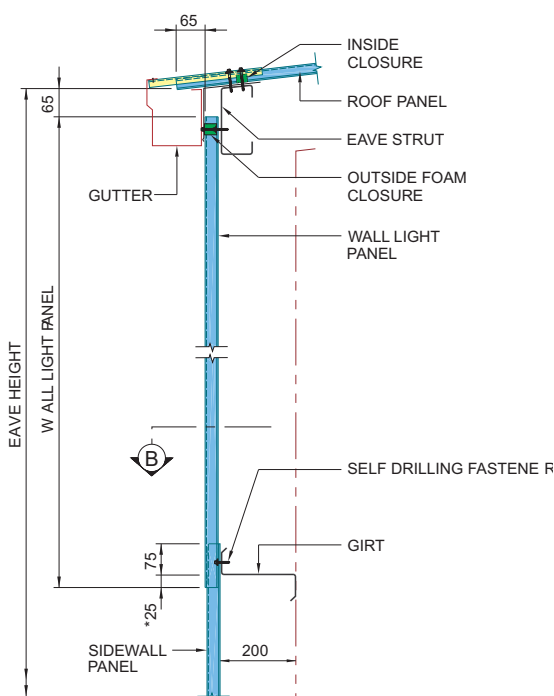

**ELEVATION : TRANSLUCENT PANEL ATWALL (WALL LIGHT)**

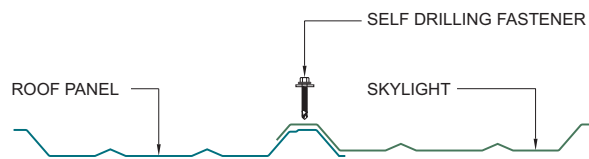

**SECTION-A : ROOF SIDE LAP**

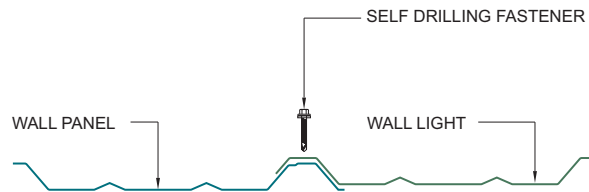

**SECTION-B : WALL SIDE LAP**

Suspended ceilings are popular and economical solutions for the interior of the building. They are aesthetical and ideal to use in pre-engineered buildings that are used for offices, show rooms, schools and supermarkets. Suspended ceilings provide good performance in thermal insulation, fire resistance and sound absorption and they are easy to install.

The suspended ceiling system recommended by Zamil Steel consists of the following:

- **Ceiling Panels:** These are 600 x 600 x 15 mm mineral fiber tiles bonded by organic and inorganic materials, formed by wet felting and heat cured.
- **Suspension System:** It consists of main runners of “T” cross-section, cross runners and edge angles. They are all made of roll-formed hot dip galvanized steel with pre-painted steel capping.
- **Hangers:** Galvanized wires 2.5 mm diameter which hang the main runner from the purlins or mezzanine joists. The maximum spacing of the hangers is 1200 mm.

Lighting fixtures, A/C inlets and outlets, etc. are available in sizes to fit the dimensions and patterns of the suspended ceiling. The specifications of suspended ceilings are given in the table below.

Special extra-resistant panel material is also available for special fire behavior and water resistance. Different architectural shapes are also possible and available upon request.



Description	Property	Value	Standard
Sound	Ceiling attenuation class (C.A.C.)	35 to 39	ASTM E413
	Noise reduction coefficient (N.R.C.)	0.55 to 0.65	ASTM C423
Light reflectance	–	LR - 1	ASTM C523
Fire resistance	Flame spread index	25 or less	ASTM E84
	Fire resistance classification	60	BS 476

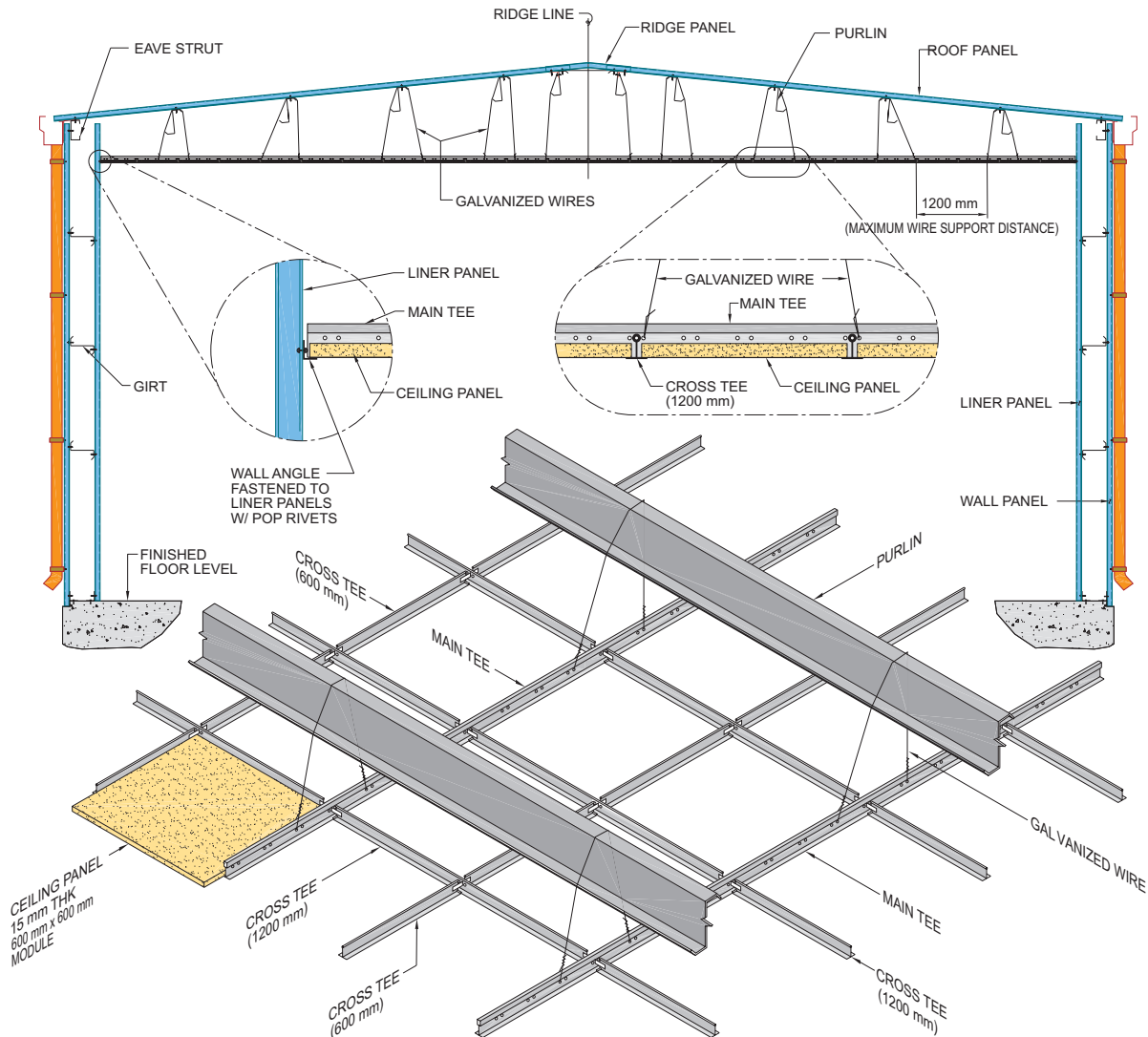

**(ISOMETRIC) : TYPICAL SUSPENDED CEILING FRAME CONNECTION**

Suspended Ceiling Components Schedule	
Part Name	Specifications
Main Tee	24 W x 38 H x 3600 L hot dip galvanized steel
Cross Tee	24 W x 25 H x 1200 L hot dip galvanized steel
Cross Tee	24 W x 25 H x 600 L hot dip galvanized steel
Wall Angel	19 W x 22 H x 3600 L wall trim
Wire	2.5 $\phi$ Galvanized wire strand
Wall Fastener <sup>1</sup>	1/8" $\phi$ Pop rivet for fastening to sheet panels
Ceiling Panel	600 x 600 x 15 THK fiber ceiling panel tiles

Note: 1. Erector/customer to provide wall fasteners when fastening to blockwall.  
 2. All dimensions are in millimeters unless otherwise specified.

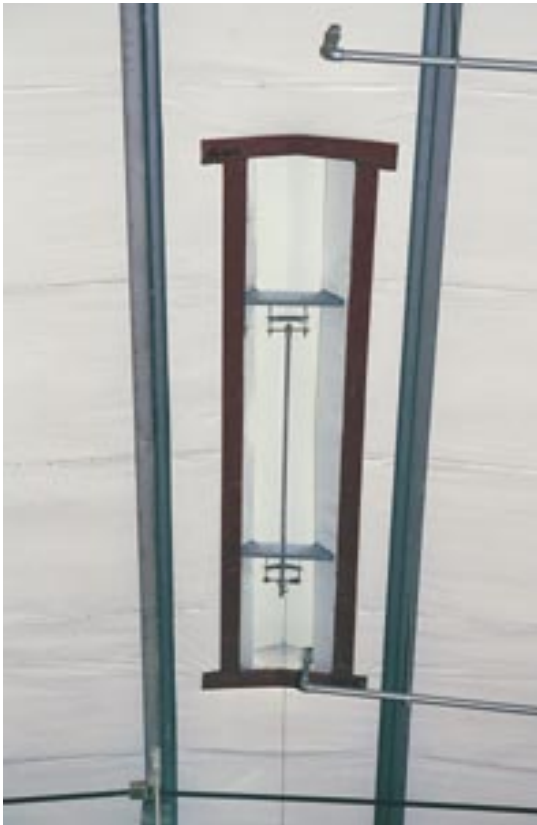

# INSULATION

# Insulation

14.1	General .....	377
14.2	Fiberglass .....	378
14.3	Rockwool .....	383
14.4	Double Faced Tape .....	385
14.5	Patching Tape .....	386
14.6	Stapler and Staples .....	387



The most practical and common type of insulation for pre-engineered steel buildings is a form of rolled blanket insulation that is available in two types:

- Fiberglass blanket
- Rockwool blanket

Zamil Steel strongly recommends the use of fiberglass insulation due to the light-weight of the blanket, ease of installation, and the strong adhesion of the glass fiber.

Rockwool insulation is preferred in countries where it is manufactured locally and where environmental restrictions require it.

The following two subsections (**section 14.2** and **section 14.3**) are devoted to these two types of blanket insulation.



The most practical type of insulation used in pre-engineered steel buildings is *fiberglass insulation*. It is recommended that roofs and walls of Zamil Steel pre-engineered steel buildings be insulated with standard fiberglass insulation which have the following specifications:

1. Fire safety properties comply with the following standard codes:  
 BS 476 Part 4 - Non combustible; ASTM E84 (via UL 723); ASTM E136  
 BS 476 Part 6 - Fire propagation  
 BS 476 Part 7 - Surface spread of flame
2. Rolls are 1000 mm wide with 50 mm side tabs.
3. Densities are 10, 12, 16 and 20 kg/m<sup>3</sup>.
4. The fiberglass blanket is laminated to a choice of functional facings to provide attractive reflective surfaces that brighten the building interior thus reducing cost of lighting. The lamination also acts as an effective vapor barrier, a control of condensation and dripping moisture, and a flame retardant component of the insulation material. The types of facings supplied are white metalized scrim kraft (WMSK), foil-reinforced kraft (FRK) and white vinyl.
5. Moisture absorption is less than one percent by weight when tested in accordance with ASTM C553, BS 2972 or BS 6676. The fiberglass insulation does not absorb moisture from the ambient air nor water by capillary action. Only water under pressure wetness the insulation, which will quickly dry out due to the material's open cell structure.
6. Non-corrosive and chemically inert, thus it will not cause or accelerate corrosion of steel, stainless steel, copper or aluminum, due to its inorganic and mineral composition (as per ASTM C665).

7. Working temperature limitations is from -4°C to 240°C.
8. Non-toxic, rot proof, odorless, non-hygroscopic and does not breed or sustain mold, fungus, bacteria or rodents. Mold growth test as per ASTM C991.
9. Thermal conductivity (K-Values) at 25°C are shown in the following table:

Insulation Thickness (mm)	K-Value (W/m.K) at densities			
	10 kg/m <sup>3</sup>	12 kg/m <sup>3</sup>	16 kg/m <sup>3</sup>	20 kg/m <sup>3</sup>
50 to 150	0.042	0.040	0.039	0.036

10. Insulation performance can be directly measured in terms of the thermal resistance (R-Values) of the material expressed in m<sup>2</sup>K/W, which is obtained by the equation, **R=T/K** where T=thickness in meters and K=thermal conductivity in W/m.K. Thermal resistance (R-Values\*) at 25°C are shown in the following table:

Insulation Thickness (mm)	R-Value (m <sup>2</sup> .K/W) at densities			
	10 kg/m <sup>3</sup>	12 kg/m <sup>3</sup>	16 kg/m <sup>3</sup>	20 kg/m <sup>3</sup>
50	1.190	1.250	1.282	1.389
75	1.786	1.875	1.923	2.083
100	2.381	2.500	2.564	2.778
150	3.571	3.750	3.846	4.167

\*The higher the R-Value, the better the insulation.

11. Acoustic insulation values are listed in the following two tables:

Sound Absorption Coefficients (as per ASTM C423)

Density kg/m <sup>3</sup>	Thickness (mm)	Coefficients of Sound Absorption						
		Sound Frequencies (Hz)						
		125	250	500	1000	2000	4000	NRC
10	50	0.25	0.45	0.70	0.80	0.85	0.85	0.70
	75	0.32	0.70	0.90	1.00	0.90	1.00	0.85
	100	0.45	1.00	1.00	1.00	1.00	1.00	1.00
	150	0.60	1.00	1.00	1.00	1.00	1.00	1.00
12	50	0.27	0.45	0.75	0.85	0.85	0.85	0.70
	75	0.35	0.75	0.95	1.00	0.95	1.00	0.90
	100	0.47	1.00	1.00	1.00	1.00	1.00	1.00
	150	0.62	1.00	1.00	1.00	1.00	1.00	1.00
16	50	0.30	0.50	0.80	0.90	0.85	0.85	0.75
	75	0.40	0.75	1.00	1.00	1.00	1.00	0.95
	100	0.50	1.00	1.00	1.00	1.00	1.00	1.00
	150	0.65	1.00	1.00	1.00	1.00	1.00	1.00
20	50	0.35	0.50	0.80	0.95	0.95	0.90	0.80
	75	0.45	0.85	1.00	1.00	1.00	0.95	0.95
	100	0.55	1.00	1.00	1.00	1.00	1.00	1.00
	150	0.70	1.00	1.00	1.00	1.00	1.00	1.00

Sound transmission losses for single metallic sheet wall plus insulation (as per ASTM E90):

Density kg/m <sup>3</sup>	Thickness (mm)	Sound Transmission Loss (dB)						
		Sound Frequencies (Hz)						
		125	250	500	1000	2000	4000	STC
10	50	12	15	16	29	31	37	24
	75	12	16	18	31	32	39	25
	100	12	17	21	34	36	42	27
	150	13	19	26	41	42	48	30
12	50	12	15	16	29	31	37	24
	75	12	16	18	31	32	39	25
	100	12	17	21	34	36	42	27
	150	13	19	26	41	42	48	30
16	50	12	15	16	31	33	39	24
	75	12	16	19	33	34	41	26
	100	12	17	22	36	38	43	28
	150	13	19	27	42	43	49	32
20	50	12	15	16	31	33	39	24
	75	12	16	19	33	34	41	26
	100	12	17	22	36	38	43	28
	150	13	19	27	42	43	49	32

Thermal transmission (U-Value) is the rate of heat transfer under steady conditions through a unit area of a roof or wall when one unit of temperature difference exists between air on both sides of that roof or wall. The installed U-Value is the reciprocal of the sum of the resistances of the component parts of the structure plus the resistance of the surfaces and any cavities within the structure. The installed U-Value for roof and walls can be calculated from the following equation.

$$U = \frac{1}{R_T}$$

$$R_T = R_{SO} + R_{ES} + R_{IN} + R_{AG} + R_{IS} + R_{SI}$$

where,

$R_T$  = total heat resistance,

$R_{SO}$  = external surface resistance,

$R_{ES}$  = external sheeting resistance,

$R_{IN}$  = insulation resistance,

$R_{AG}$  = air gap resistance (if any),

$R_{IS}$  = internal sheeting or lining resistance (if any),

$R_{SI}$  = internal surface resistance.

The following table shows the installed thermal transmission (U-Value) for roof and walls of pre-engineered buildings using a 50, 75, 100 and 150 mm thick fiberglass blankets having a density of 10 kg/m<sup>3</sup>, and based on summer conditions as calculated from the above formula.

Insulation Thickness (mm)	U-Value	
	Roof	Wall
	(W/m <sup>2</sup> . K)	(W/m <sup>2</sup> . K)
50	0.642	0.678
75	0.464	0.483
100	0.364	0.375
150	0.254	0.259

Examples for the calculation of installed R-Value are shown on the next page.

The following examples illustrate the calculations of the installed “R” value for the roof and wall construction using fiberglass insulation. Note that

resistances in horizontal construction may differ from resistances for vertical construction.

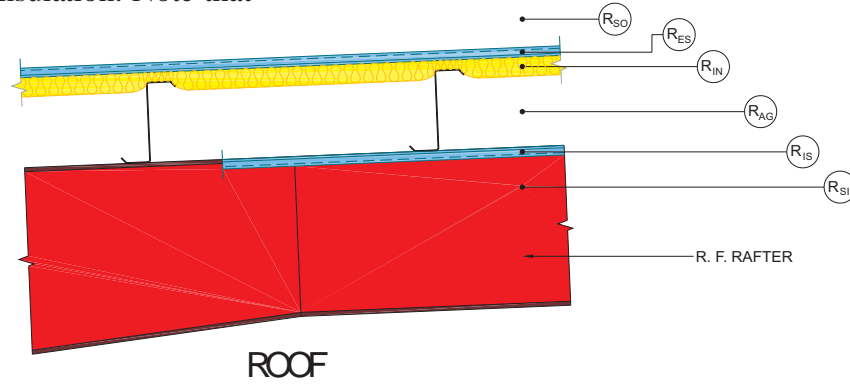

### Roof Construction: Summer Condition

Element	Construction	Resistance (R)	
		ft <sup>2</sup> h.½F/Btu	m <sup>2</sup> .K/w
R <sub>SO</sub>	Outside surface (wind speed = 7.5 mph)	0.25	0.044
R <sub>RS</sub>	Roof sheeting	0.00	0.000
R <sub>IN</sub>	100mm fiberglass insulation at 24½C = 75½F	12.72	2.240
R <sub>AG</sub>	Air gap (200mm)	0.92	0.162
R <sub>IS</sub>	Liner	0.00	0.000
R <sub>SI</sub>	Inside surface (still air)	0.92	0.162
TOTAL HEAT RESISTANCE (R <sub>T</sub> )		14.81	2.608

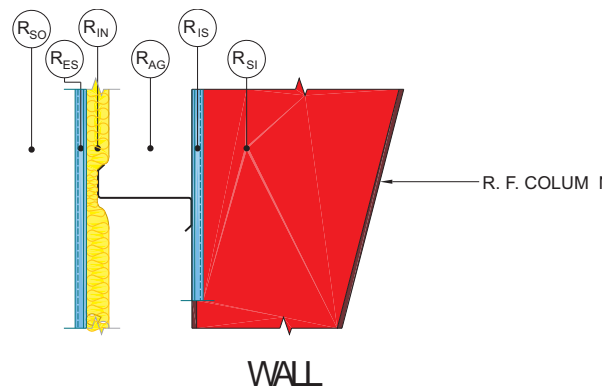

### Wall Construction: Summer Condition

Element	Construction	Resistance (R)	
		ft <sup>2</sup> h.½F/Btu	m <sup>2</sup> .K/w
R <sub>SO</sub>	Outside surface (wind speed = 7.5 mph)	0.25	0.044
R <sub>ES</sub>	Roof sheeting	0.00	0.000
R <sub>IN</sub>	100mm fiberglass insulation at 24½C = 75½F	12.72	2.240
R <sub>AG</sub>	Air gap (200mm)	0.92	0.162
R <sub>IS</sub>	Liner	0.00	0.000
R <sub>SI</sub>	Inside surface (still air)	0.92	0.162
TOTAL HEAT RESISTANCE (R <sub>T</sub> )		14.81	2.608

REFERENCES:

- Owens, “Fundamentals of Heat Transfer”, Corning Fiberglass.
- Paul Marsch, “Thermal Insulation and Condensation”, the Construction Press, 1979.

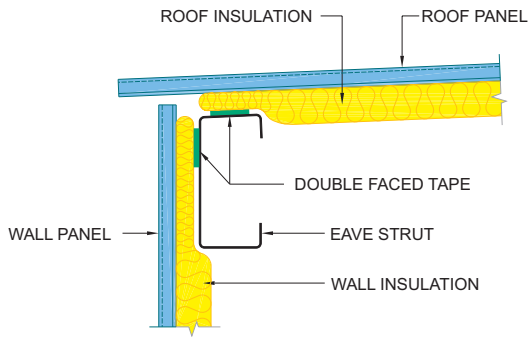

**DETAIL-A** : INSULATION AT EAVE

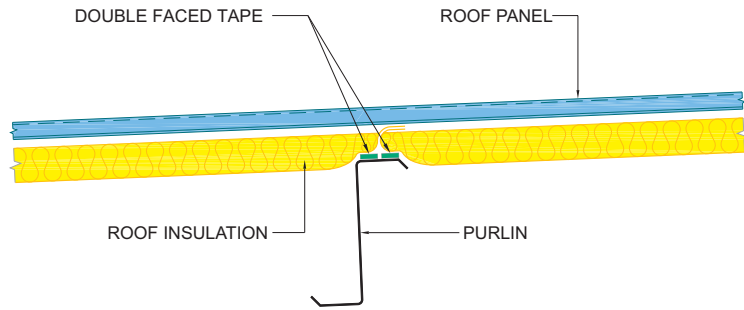

**DETAIL-B** : INSULATION AT END LAP

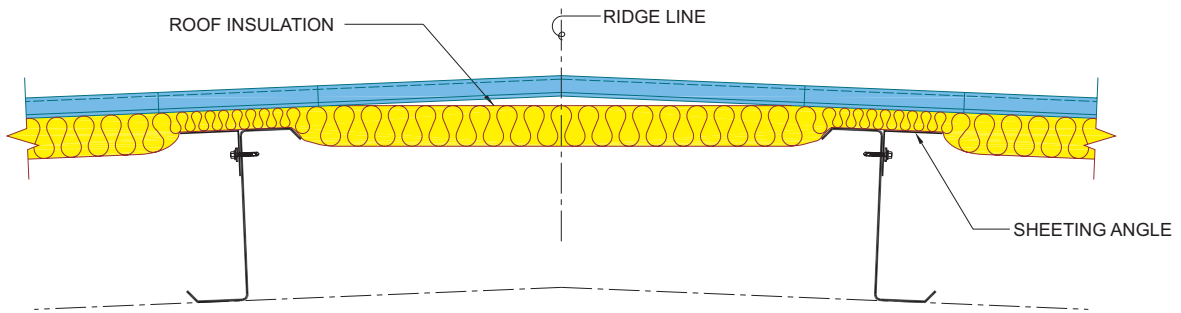

**DETAIL-C** : INSULATION AT RIDGE

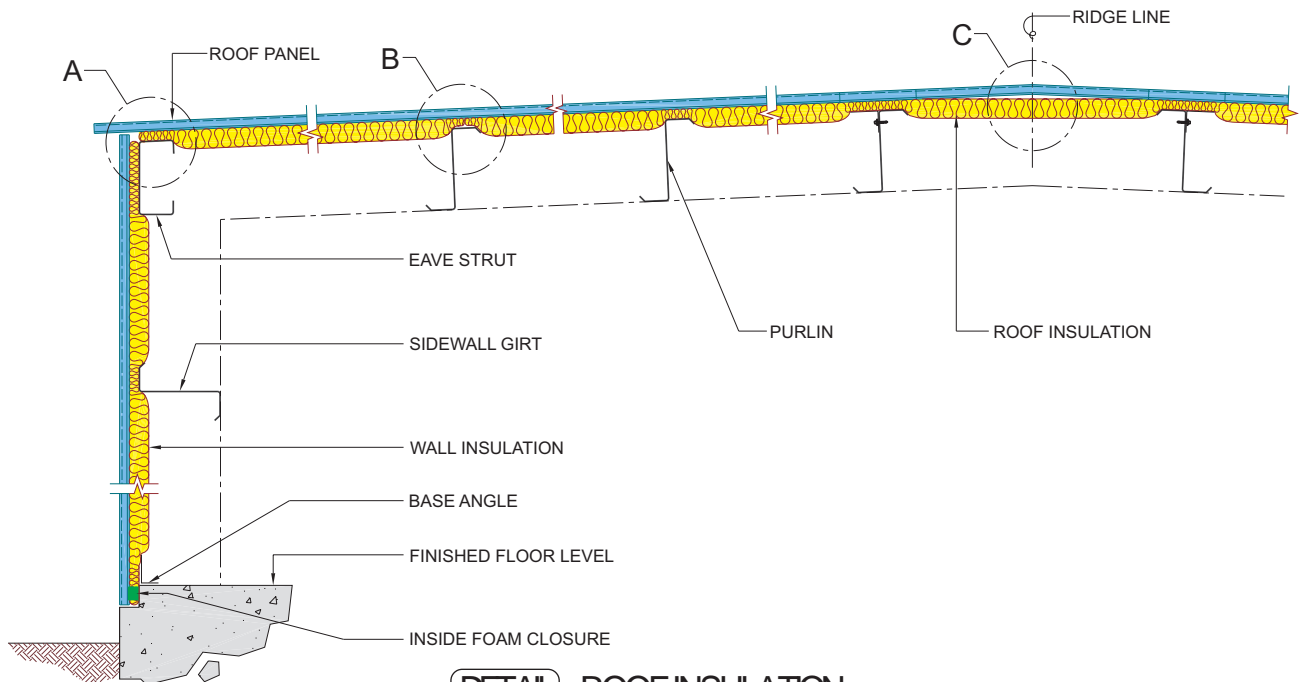

**DETAIL** : ROOF INSULATION

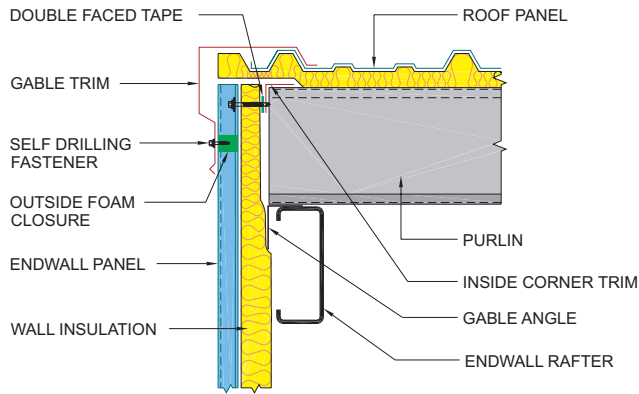

**DETAIL : GABLE WITH INSULATION**

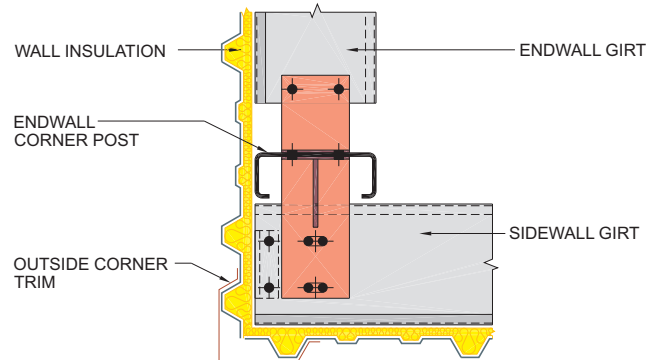

**DETAIL : CORNER WITH INSULATION**

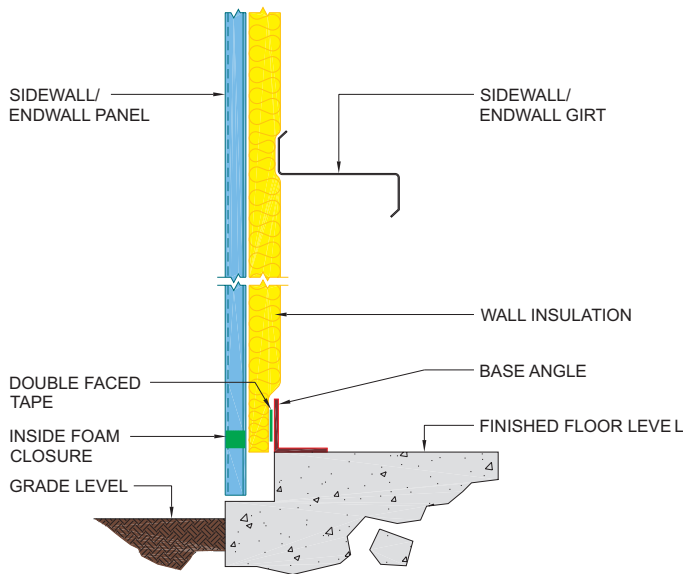

**DETAIL : ENDWALL/SIDEWALL INSULATION (AT BASE)**

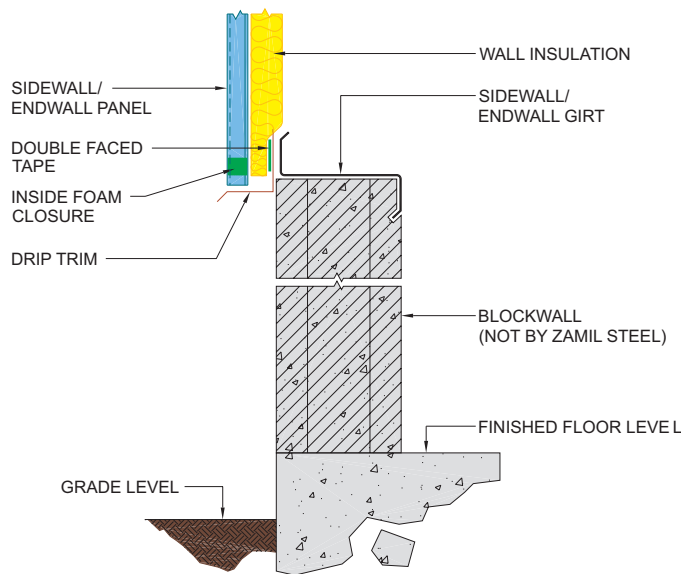

**DETAIL : ENDWALL/SIDEWALL INSULATION (ABOVE BLOCKWALL)**

**DETAIL : WALL INSULATION**

**Rockwool** is a mineral non-organic fibrous material of insulating properties and fire resistance characteristics. It is commonly utilized in many fields of thermo-acoustic applications.

Rockwool is manufactured by melting certain basaltic igneous volcanic rocks in a furnace at a considerably high temperature (1500°C). The molten rock is then spun into wool fibers that are further processed through different chemical and mechanical operations to end up with the final desired product.

Rockwool insulation products are made in different types and sizes to suit numerous application needs. The basic types of rockwool are:

- Stitched mattresses
- Felted blankets
- Loose wool (long fibers)
- Carded loose wool (short fibers)
- Semi rigid panels
- Rigid panels
- Pipe sections

### Rockwool characteristics and applications:

Rockwool products possess superior characteristics and properties among all other thermo-acoustical insulation materials. Rockwool is:

- a) Efficient in thermal insulation applications
- b) An inorganic, non-aging and dimensionally stable material
- c) A water repellent material
- d) A non-combustible and non-flammable material
- e) Chemically and electrically inert
- f) A non-hazardous and medically safe material

- g) Suitable for high temperature applications, as it maintains its insulating characteristics efficiently at temperatures of up to 700°C

Rockwool products have many practical uses, some of which are:

- Insulation of roofs and walls of buildings such as, factories, cold stores, recreational and commercial facilities
- Insulation of refineries and petrochemical plants
- Insulation of boilers and chimneys
- Insulation of refrigeration equipments and ducting
- As a main component in the manufacture of false ceilings, etc.

**Rockwool insulating properties:**

Below are the R-Values for 30 kg/m<sup>3</sup> density rockwool insulation which is recommended for use on the roofs and walls of pre-engineered metal buildings.

Insulation thickness (mm)	30 kg/m <sup>3</sup> Density	
	R-Value @ 20°C	
	(h.ft <sup>2</sup> .°F/Btu)	(m <sup>2</sup> . K/W)
30	4.07	0.71
50	6.75	1.19
100	13.51	2.38

Typical acoustic insulation values for rockwool are listed in the following two tables.

Insulation thickness (mm)	Coefficients of Sound Absorption (BS-3638-1980, ISO 354)					
	Sound Frequencies in H <sub>z</sub>					
	125	250	500	1000	2000	4000
50	0.25	0.60	0.80	1.00	1.00	1.00
80	0.35	0.70	0.90	1.00	1.00	1.00
100	0.55	0.85	1.00	1.00	1.00	1.00

Insulation thickness (mm)	Sound Reduction Index (dB)					
	Sound Frequencies in H <sub>z</sub>					
	125	250	500	1000	2000	4000
50	15	21	22	38	52	61
80	16	22	23	40	54	63
100	16	22	24	43	57	67



**Double faced tape** is mainly used in Zamil Steel pre-engineered buildings where insulation is to be secured to the eave strut, gable angle, base angle and other secondary structural members.

Although double faced tape is not intended to support the insulation weight by itself, it maintains a secured seal that assures the optimum efficiency of the insulation system.

Double faced tape comes in rolls and has a high tack pressure-sensitive rubber based adhesive on both sides of a paper carrier. It has an excellent adhesion property aside from being easy and quick to apply. It exhibits good weatherability when exposed to extreme temperatures ranging from  $-29\frac{1}{2}^{\circ}\text{C}$  to  $79\frac{1}{2}^{\circ}\text{C}$ .

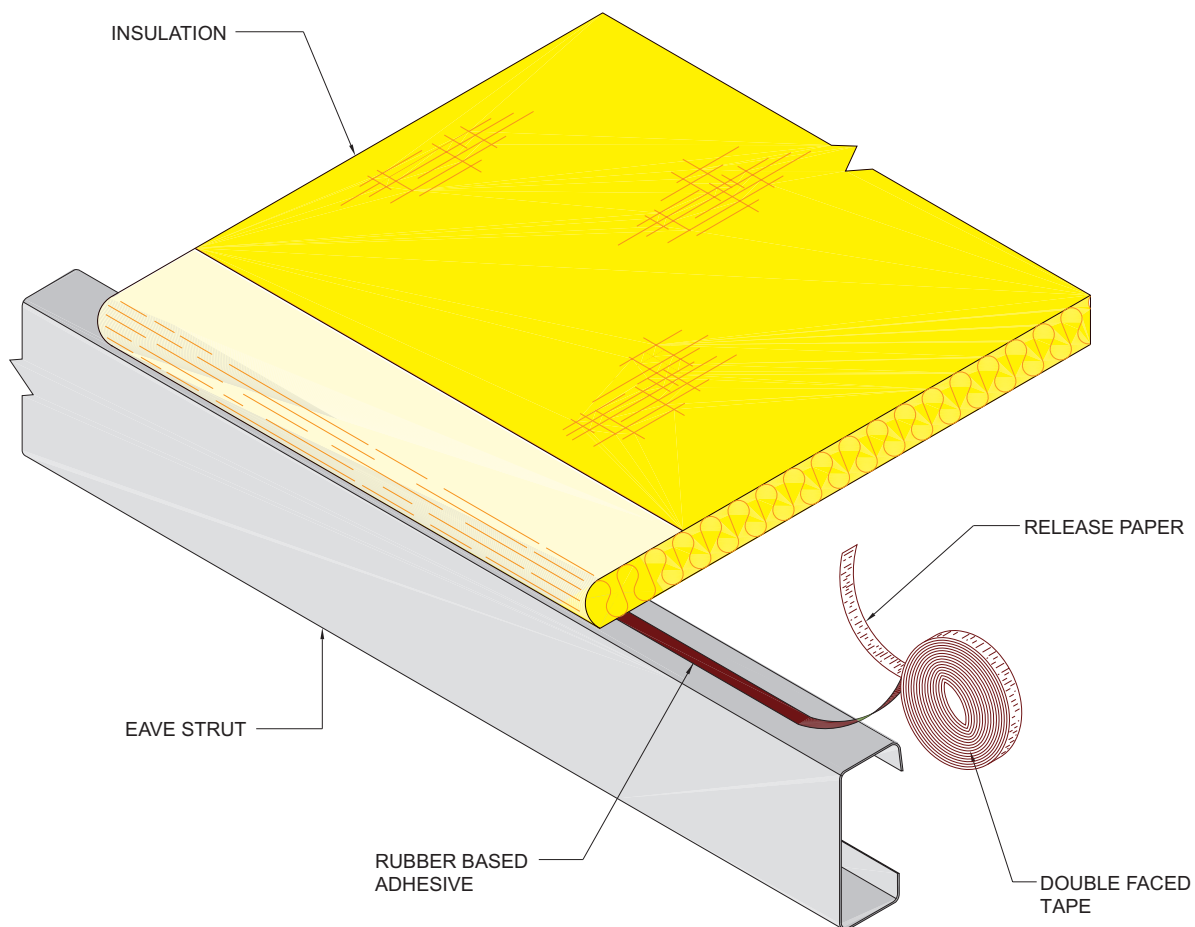

DOUBLE FACED TAPE AT EAVE STRUT

**Patching tape** is used primarily to seam or reinforce and repair a weakened or torn area of the face of the insulation blanket due to transport or installation mishandling or accidents.

Patching tape comes in rolls and is made of a white metalized polypropylene (WMP) scrim that has a kraft backing rubber based adhesive and a release

liner. It has an excellent bond and long lasting performance aside from being quick and easy to apply. It exhibits good weatherability when exposed to extreme temperatures ranging from  $-29\frac{1}{2}^{\circ}\text{C}$  to  $66\frac{1}{2}^{\circ}\text{C}$  and has a tensile strength of 9.84 kg/cm width. Patching tapes are not intended to support insulation facing.

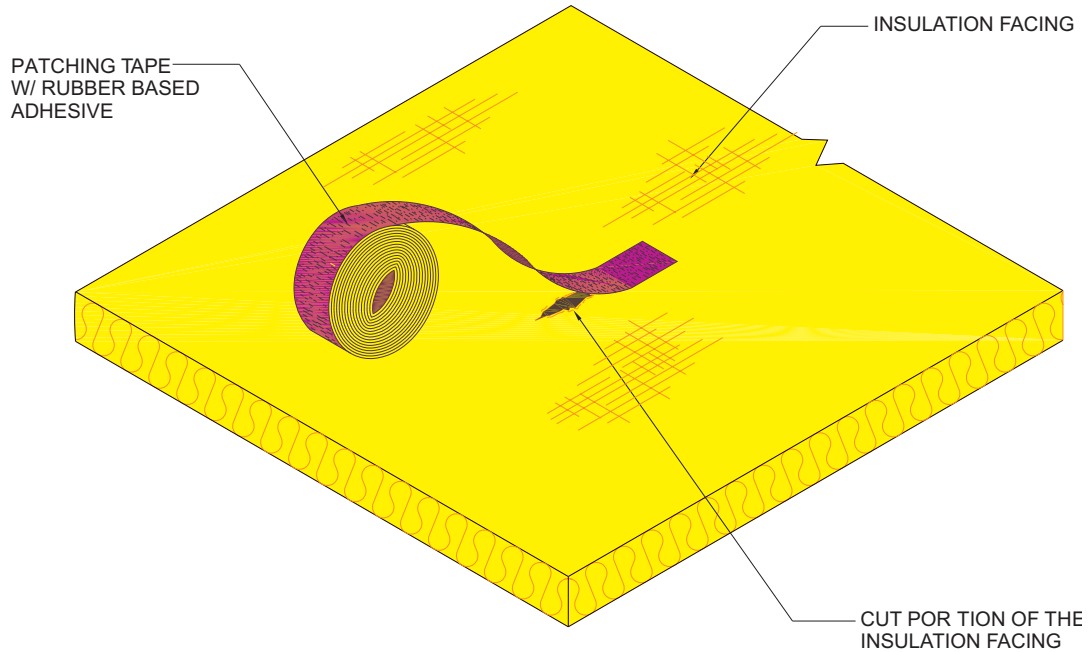

PATCHING THE INSULATION BLANKET

Zamil Steel uses a special type of **stapler** and **staples** for joining metal building insulation tabs or end projections. The stapler is a “pliers type” which is light and easy to use and requires minimal amount of energy to operate. The staples are unique in the sense that they have an undulated or wave like appearance aside from having chisel point ends. These undulated staples keep insulation tabs locked tighter and provide more holding power than any other staple.

The stapler and staples are standard supplied sundries of Zamil Steel.





**SUNDRY PARTS**

# Sundry Parts

15.1	General .....	391
15.2	Anchor Bolts .....	392
15.3	Primary Connection Bolts .....	393
15.4	Secondary Connection Bolts .....	395
15.5	Sheeting Fasteners .....	396
15.6	Pop Rivets .....	397
15.7	Foam Closures .....	398
15.8	Bead Mastic .....	399
15.9	Flowable Mastic .....	400
15.10	Pipe Flashing .....	401

**Sundry parts** consist of two categories:

- *Standard buyouts* which are items that form a part of the basic Zamil Steel buildings but are not manufactured by Zamil Steel. These include anchor bolts, primary connections bolts, secondary connection bolts, sheeting fasteners, pop rivets, foam closures, bead mastics, flowable mastics, double face (insulation) tape, packing tape, and stapler with staples.
- *Miscellaneous items* that are manufactured by Zamil Steel such as clips, flange braces, sag rods, brackets, stiffeners, end plates, pre-galvanized grating, chequered plates, etc. that are required to complete a building.

Zamil Steel maintains a steady and up-to-date stock of all these items to ensure immediate availability.



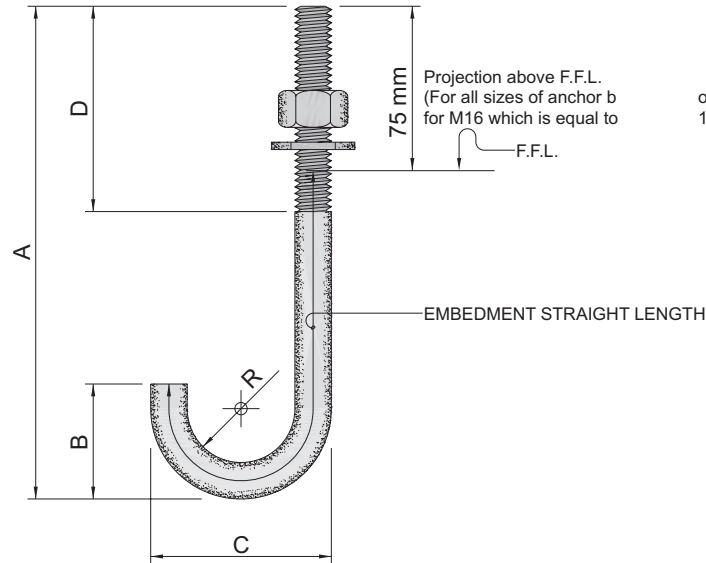

### Dimensional Properties

Bolt		Weight (kg)	A (mm)	B (mm)	C (mm)	D (mm)	Radius "R" (mm)	Total Straight Length (mm)	Embedment Straight Length (mm)
Nominal Diameter	Thread Pitch								
M16	2.00	0.80	400	90	80	100	24	511	436
M20	2.50	1.56	500	110	100	125	30	636	561
M24	3.00	2.73	600	140	128	125	40	775	700
M30	3.50	6.15	900	170	160	150	50	1114	1039
M36	4.00	10.04	1000	210	192	200	60	1263	1138

### Allowable Loads

Bolt Nominal Diameter	Tension (kN)	Shear (kN)	Pull-out Strength (kN)
M16	26.54	13.67	24.1
M20	41.47	21.36	39.5
M24	59.72	30.76	49.1
M30	93.31	48.07	75.1
M36	134.36	69.22	85.8

**NOTES:**

- ANCHOR BOLT MATERIAL SPECIFICATION CONFORMS TO JIS-G3101 SS400 OR EQUIVALENT.
- SHEAR AND TENSION ARE BASED ON GROSS NOMINAL AREA OF THE BOLT.
- PULL-OUT STRENGTH IS BASED ON 2.07 kN/cm<sup>2</sup> CONCRETE COMPRESSIVE STRENGTH.
- ALLOWABLE LOADS DO NOT INCLUDE COMBINED SHEAR AND TENSION.
- ALLOWABLE LOADS MAY BE INCREASED BY 33% IF DUE TO WIND.
- ALL BOLTS ARE HOT DIP GALVANIZED (THREADS ARE SPRAY IN COATED).



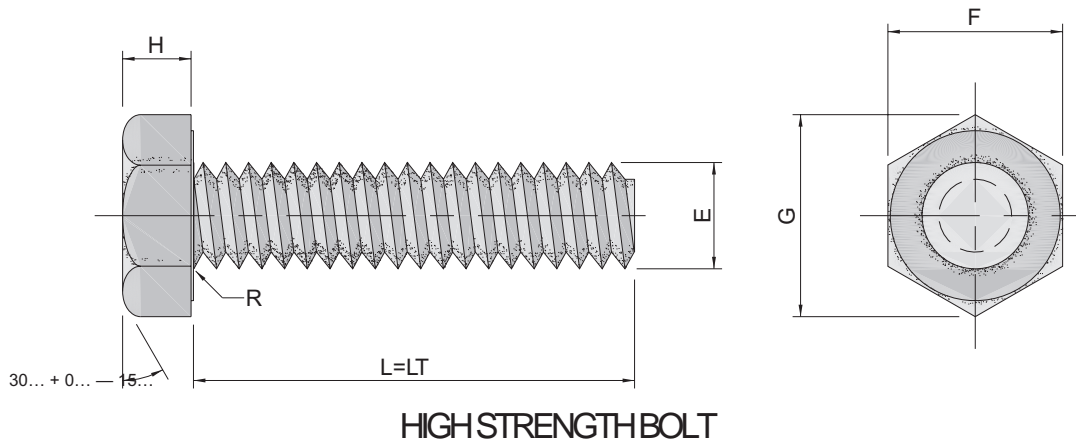

**Dimensional Properties (All figures are in mm, unless noted)**

Bolt		E	F		G		H		R		Available Bolt Length "L" and Thread Length "LT"			
		Body Diameter	Width Across Flats		Width Across Corners		Height		Radius of Fillet					
Nominal Dia.	Thread Pitch	Max.	Max.	Min.	Max.	Min.	Max.	Min.	Max.	Min.	L	LT	L	LT
M12	1.75	12.00	19.00	18.67	-	21.10	7.68	7.32	-	0.23	35	FULL	55	FULL
M16	2.00	16.70	27.00	26.16	31.18	29.56	10.75	9.25	-	0.53	50	FULL	70	FULL
M20	2.50	20.84	34.00	33.00	39.26	37.29	13.40	11.60	-	0.53	60	FULL	80	FULL
M24	3.00	24.84	41.00	40.00	47.34	45.20	15.90	14.10	-	0.79	70	FULL	90	FULL
M27	3.00	27.84	46.00	45.00	53.12	50.85	17.90	16.10	-	1.57	90	FULL	100	FULL
M30	3.50	30.84	50.00	49.00	57.74	55.37	19.75	17.65	-	1.57	100	FULL	120	FULL

**Allowable Loads**

Bolt		Tension (kN)	Shear (kN)	
Nominal Diameter	Thread Pitch		Single	Double
M12	1.75	30.16	15.38	30.76
M16	2.00	55.63	28.37	56.74
M20	2.50	86.92	44.33	88.66
M24	3.00	125.16	63.83	127.66
M27	3.00	158.41	80.79	161.57
M30	3.50	195.56	99.74	199.48

NOTES:  
 1. TENSION IS BASED ON GROSS NOMINAL AREA.  
 2. SHEAR IS BASED ON BEARING TYPE CONNECTION WITH THREADS INCLUDED IN SHEAR PLANE.  
 3. ALL BOLTS ARE HIGH STRENGTH BOLTS AND HOT DIP GALVANIZED.  
 4. USAGE: FOR PRIMARY FRAME CONNECTIONS.  
 5. AVAILABLE TENSILE & SHEAR STRESS:  
 a. FOR M12 BOLTS: (Ft=26.67 kN/cm<sup>2</sup>) TENSILE (Fv=13.60 kN/cm<sup>2</sup>) SHEAR  
 a. FOR BOLTS>M12: (Ft=27.67 kN/cm<sup>2</sup>) TENSILE (Fv=14.11 kN/cm<sup>2</sup>) SHEAR

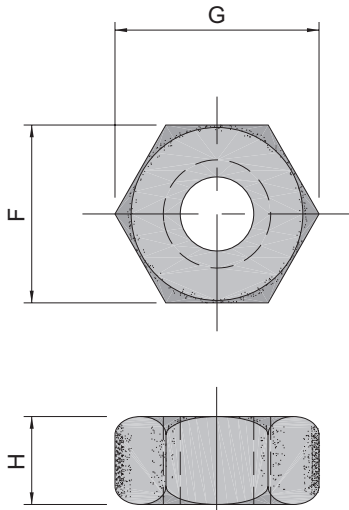

NUT

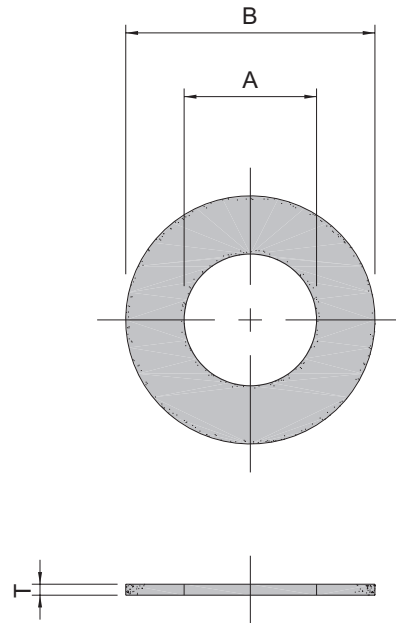

WASHER

Bolt Sizes		Nut					
		F		G		H	
		Width Across Flats (mm)		Width Across Cornners (mm)		Thickness (mm)	
Nom. Dia.	Thread Pitch	Max.	Min.	Max.	Min.	Max.	Min.
M12	1.75	19.00	18.67	–	21.10	10.00	9.64
M16	2.00	27.00	26.16	31.18	29.56	17.10	16.40
M20	2.50	34.00	33.00	39.26	37.29	20.70	19.40
M24	3.00	41.00	40.00	47.34	45.20	24.20	22.90
M27	3.00	46.00	45.00	53.12	50.85	27.60	26.30
M30	3.50	50.00	49.00	57.74	55.37	30.70	29.10

Washer					
A		B		T	
Inside Diameter (mm)		Outside Diameter (mm)		Thickness (mm)	
Max.	Min.	Max.	Min.	Max.	Min.
14.40	14.00	27.00	25.70	4.60	3.10
18.40	18.00	34.00	32.40	4.60	3.10
22.50	22.00	42.00	40.40	4.60	3.10
26.50	26.00	50.00	48.40	4.60	3.40
30.50	30.00	56.00	54.10	4.60	3.40
33.60	33.00	60.00	58.10	4.60	3.40

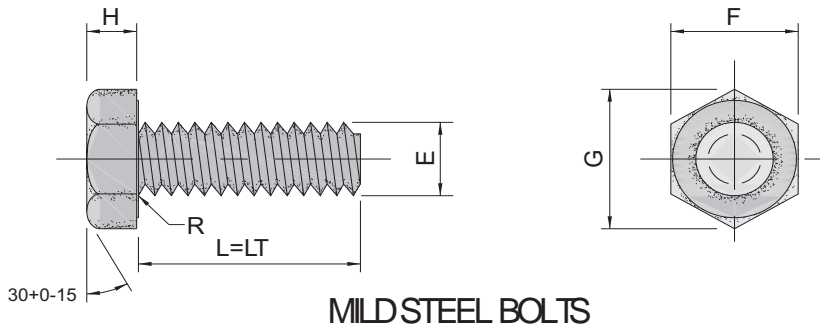

1. TENSION IS BASED ON GROSS NOMINAL AREA.
2. SHEAR IS BASED ON BEARING TYPE CONNECTION WITH THREADS INCLUDED IN SHEAR PLANE.
3. MILD STEEL BOLTS ARE ELECTRO GALVANIZED WITH ALLOWABLE TENSILE AND SHEAR STRENGTH:  
( $F_t = 13.33 \text{ kN/cm}^2$ ) TENSILE  
( $F_v = 6.80 \text{ kN/cm}^2$ ) SHEAR
4. USAGE: FOR PURLIN AND GIRT CONNECTIONS.

MILD STEEL BOLTS

Mild Steel Bolt

Bolt		E		F		G		H		R		LT	L	Tension	Shear	
		Body Diameter (mm)		Width Across Flats (mm)		Width Across Corners (mm)		Height (mm)		Radius of Fillet (mm)					Single	Double
Nom. Dia.	Thread Pitch	Max.	Min.	Max.	Min.	Max.	Min.	Max.	Min.	Max.	Min.			(kN)	(kN)	(kN)
M12	1.75	12.00	-	19.01	18.67	-	21.10	7.65	7.32	-	0.60	Full	35	17.3	7.69	15.38

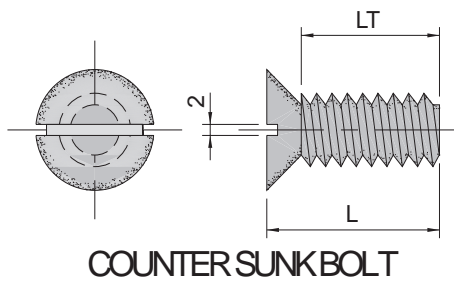

COUNTER SUNK BOLT

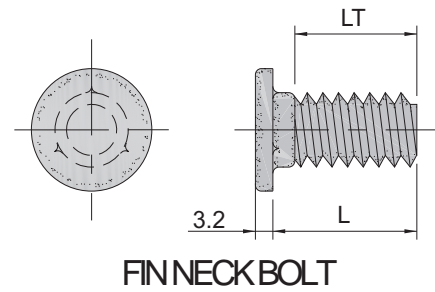

FIN NECK BOLT

Counter Sunk Bolt and Fin Neck Bolt

Description	Bolt		L	LT	Tensile Strength (kN)
	Nominal Diameter	Thread Pitch	Bolt Length (mm)	Thread Length (mm)	
Counter Sunk	M12	1.75	25	Full	15.08
Fin Neck Bolt	M12	1.75	35	Full	15.08

1. TENSION IS BASED ON GROSS NOMINAL AREA.
2. MATERIAL AND QUALITY CONFORMS TO MILD STEEL BOLT SPECIFICATIONS.
3. USAGE:
  - a) COUNTER SUNK BOLT - FOR SINGLE AND DOUBLE SLIDING DOORS
  - b) FIN NECK BOLT - FOR FRAMED OPENINGS, MEZZANINE'S CHECKERED PLATES, AND FASCIAS.

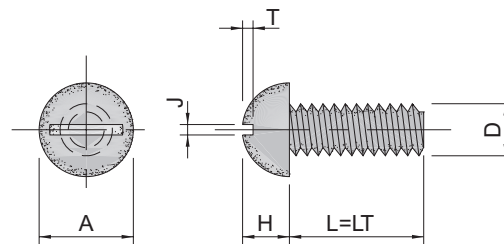

STOVE BOLTS

Stove Bolt

Bolt		D		A		H		J		T		L	LT	Tensile Strength (kN)
Nominal Diameter	Thread	Max.	Min.	Max.	Min.	Max.	Min.	Max.	Min.	Max.	Min.			
M6	1.00	10.50	9.80	4.20	3.80	1.90	1.60	2.76	2.18			16	Full	3.77

1. TENSION IS BASED ON GROSS NOMINAL AREA.
2. MATERIAL AND QUALITY CONFORMS TO MILD STEEL BOLT SPECIFICATIONS.
3. USAGE: FOR VALLEY GUTTERS AND RIDGE VENTILATORS.

FOR SINGLE SKIN ROOF PANEL

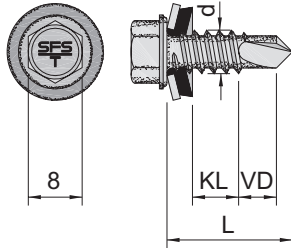

SPEDEC SD5

FOR TEMPCON PANEL

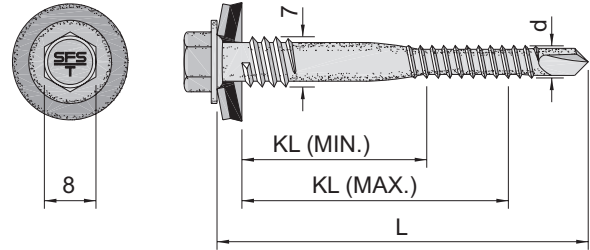

SPEDEC SDC5

Available Sizes

d Diameter (mm)	VD Maximum Drilling Capacity (mm)	KL Thickness of Fixed Material (mm)	L Length (mm)
5.5	5	9	25
5.5	5	43	57

Self Driller, Carbon Steel, Case Hardened, Zinc-plated 10-15 microns, Chromate dipped with assembled sealing washer.

Available Sizes

d Diameter (mm)	KL Thickness of Fixed Material		L Length (mm)
	Min.	Max.	
5.5	31	40	62
5.5	39	55	77
5.5	54	85	107
5.5	60	115	137

Self Driller, Carbon Steel, Case Hardened, Zinc-plated 10-15 microns, Chromate dipped with assembled sealing washer.

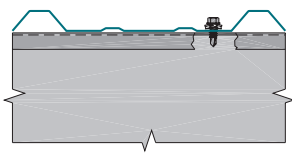

DETAIL AT ROOF

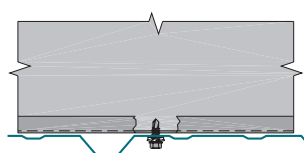

DETAIL AT WALL

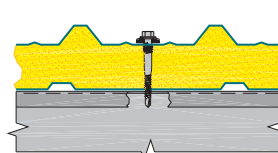

DETAIL AT ROOF

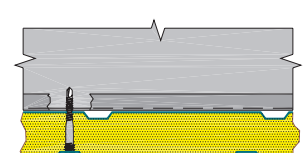

DETAIL AT WALL

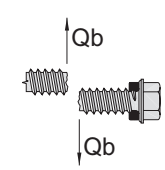
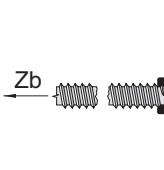
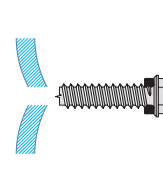
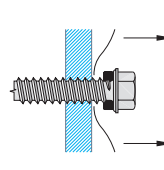
Type	 SHEAR BREAKING LOAD, Qb	 TENSILE BREAKING LOAD, Z I	 PULLOUT LOAD, Fz	 PULLOVER LOAD, Fu
SPEDEC SD5	10 kN	16 kN	3.4 kN	4.95 kN
SPEDEC SDC5	10 kN	16 kN	2.8 kN	3.50 kN

NOTE: FOR SINGLE SKIN WALL PANELS, INTERIOR PARTITION PANELS, INTERIOR ROOF & WALL LINER PANELS AND SOFFIT PANELS SIMILAR SELF DRILLING FASTENERS ARE USED BUT WITH A FIXED WASHER.

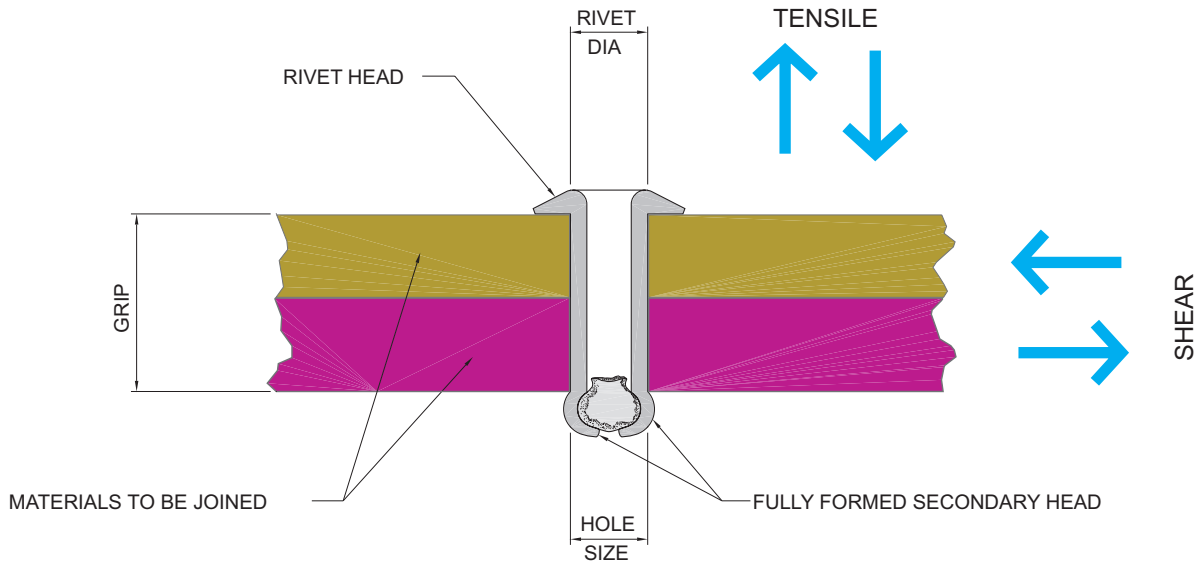

A TYPICAL RIVET JOINT CONNECTION SHOWING SELECTION FACTORS

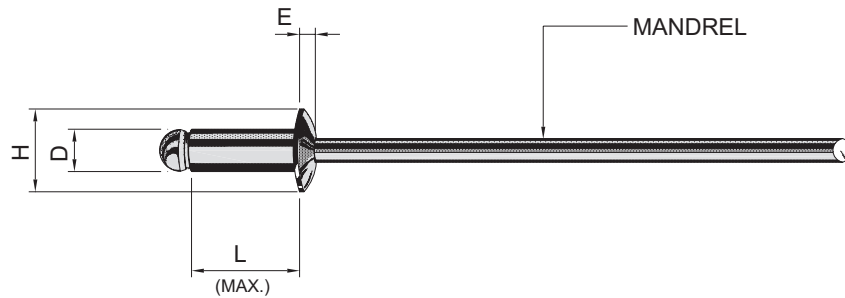

Rivet Selection Chart								
Rivet Type	"D" Rivet Body Diameter (Inches)	Hole Size (mm)	Grip Range (mm)	"L" Length Under Head	"H" Head Diameter (mm)	"E" Head Height (mm)	Typical Ultimate Strengths (kN)	
							Shear	Tensile
Carbon Steel Plated Rivet with Coated Carbon Steel Mandrel								
SD46BS	1/8	3.28-3.38	7.95-9.53	13.08	6.35	1.02	1.312	1.890
Stainless Steel Rivet with Stainless Steel Mandrel								
SSD46SSBS	1/8	3.28-3.38	7.95-9.53	13.08	6.35	1.02	2.446	3.114

NOTE: RIVETS SHOWN IN ABOVE CHART ARE OPEN END TYPE WITH DOME HEAD STYLE.

**Foam closures** are Zamil Steel standard supplied sundry parts for weather tight sealing between panels and trims at the eave, gable, base, canopy, ridge as well as above blockwall areas. The types of foam closures supplied depends on the panel profile used in the pre-engineered steel building. The company keeps inventories of all these types in anticipation of the growing demands for Zamil Steel building products worldwide.

Vapor absorption and water vapor transmissions characteristics of foam closures are barely measurable making the eave, gable and base of the building walls free of moisture that causes rust and mildew. The ease and speed of installation, due to the interlocking dovetail shape at the end of each foam closure, eliminate gaps at connections and assure a snug fit with no closure sag out.

Zamil Steel foam closures are made of soft, but rigid, polyethylene foam that has very high resistance to ultraviolet rays, can withstand harsh environments and resists some aggressive chemical attacks. The polyethylene foam can also resist the usual damaging effects of ozone in the air.

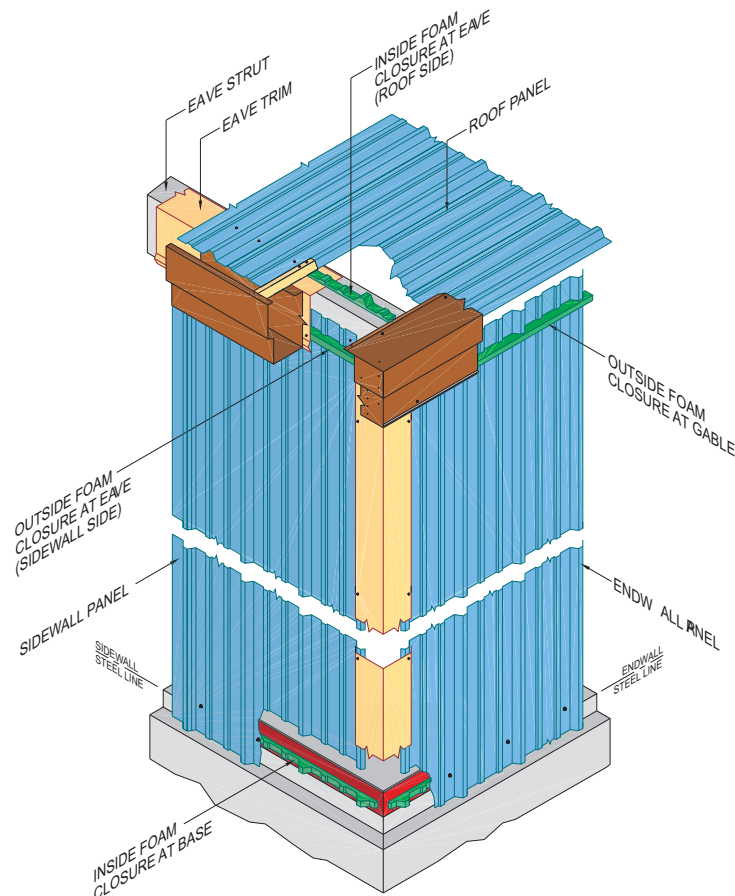

FOAM CLOSURES LOCATION AT CORNER OF A TYPICAL BUILDING

**Bead mastic** is a high performance tacky elastic butyl tape with silicone release paper. It is designed to bond to Zinalume, Galvalume, Kynar 500, aluminized steel, galvanized metal, aluminum, silicone polyester coats, polyvinyl fluoride painted metals, concrete, fiber-reinforced plastics (FRP) and similar substrates. Bead mastics are engineered to withstand extreme roof temperature while offering low temperature compressibility and resistance to cold flow. They are also formulated without asbestos fillers and are supplied in rolls for easy application.

Zamil Steel uses two types of bead mastic, single and double bead mastic. Although both types can be used for sealing purposes in a wide variety, single bead mastic is primarily used for roof end laps while double bead mastic is specifically used for heavy duty sealing of valley gutters.

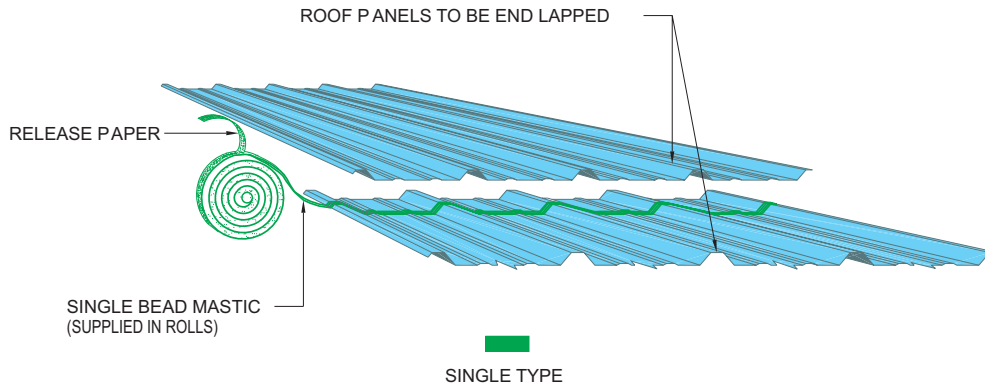

**BEAD MASTIC PROFILE**

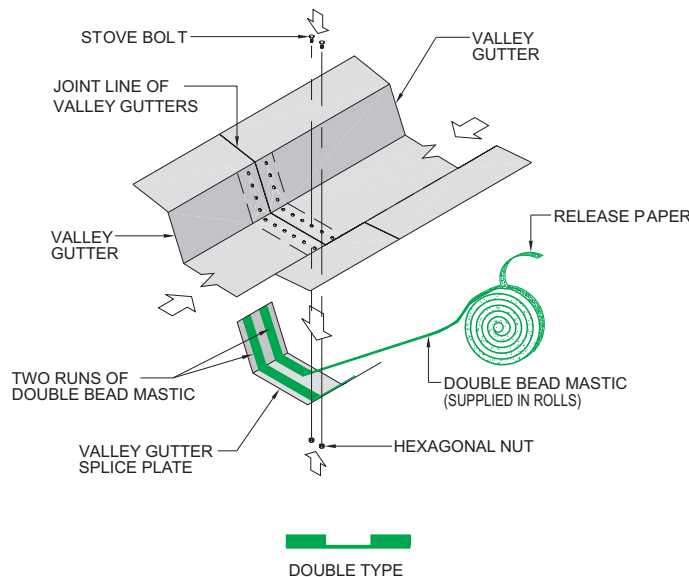

**BEAD MASTIC PROFILE**

**Flowable mastic** is a high performance solvent release pigmented acrylic compound sealant. It is ideal for sealing critical laps in gutters, downspouts, aluminum windows, ridge ventilators, pipe flashings, etc. It exhibits good adhesion to many pre-engineered building surfaces including siliconized painted metal, aluminized steel, Zinalume, wood, concrete, and fiber-reinforced plastics (FRP). Flowable mastic remains ductile in the presence of ultraviolet and infrared radiation, making it an excellent general purpose sealant.

Flowable mastic also exhibits good weatherability when exposed to rain, ultraviolet and infrared radiation, atmospheric hydrocarbons and extreme temperatures ranging from  $-18^{\circ}\text{C}$  to  $88^{\circ}\text{C}$ . It also has exceptional resistance to cuts and tears making it ideal for sealing dynamically moving joints.

Flowable mastic is supplied in cartridges. Standard caulking guns, or industrial pumps and flow gun equipment, can be used successfully for easy and quick compound application. Hoses from pumps or header systems and all seals or packing must be teflon or polypropylene.

Before application, clean metal surface with cleaning solvent that is recommended by the manufacturer. Detergents or soaps and water cleaning treatments are not recommended. Excessive uncured material should be quickly removed from the surface with isopropyl alcohol, aromatic or ketone type solvents.

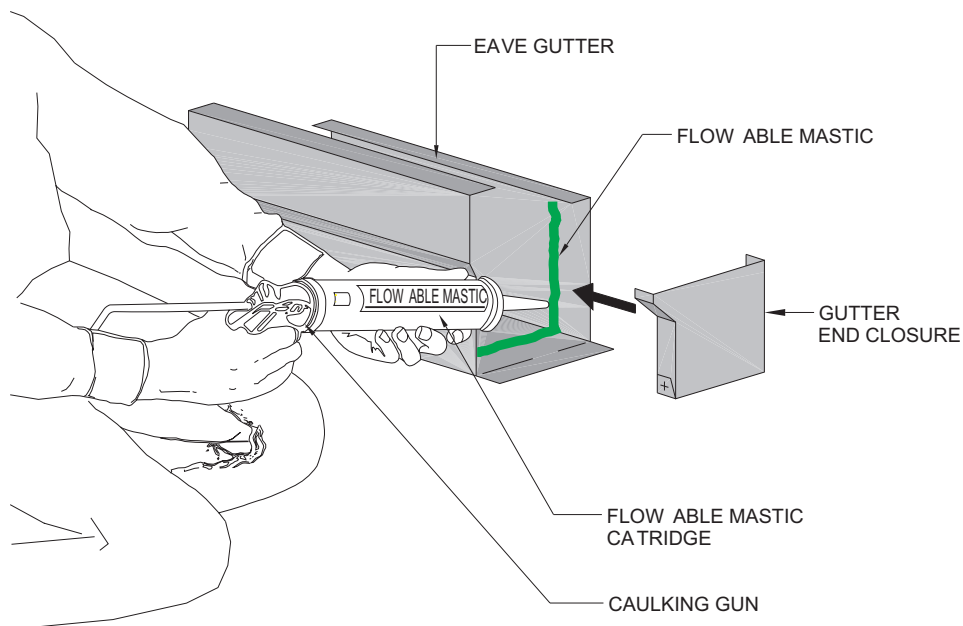

APPLICATION OF FLOWABLE MASTIC



Whenever pipes or tubes protrude through the roof panel of a pre-engineered steel building, **pipe flashing** is the fastest and most economical solution recommended for preventing water leakage. Pipe flashing is flexible enough to accommodate any roof panel profile, any protruding member (be it round, square or oval shaped) and any roof slope. And because pipe flashing allows for movement between the protruding member and the roof there is no risk of a breakdown of the seal thus translating into a drastic reduction in maintenance costs.

Pipe flashing is made of silicon rubber or EPDM (Ethylene Propylene Diene Monomer) and works

effectively with any roof panel materials such as steel, aluminum, copper, lead, asbestos, cement, plastic fiberglass or timber. It is specifically compounded for exceptional resistance to ozone, ultra violet rays and water. It remains pliable and is an effective seal over a wide range of temperatures from - 60°C to 200°C.

Pipe flashing provides a neat looking finish as its rubber sleeve can be trimmed to the exact outside diameter of the protruding member to provide a perfect fit. Sizes are available for pipes with outside diameters ranging from 4 mm to 175 mm.

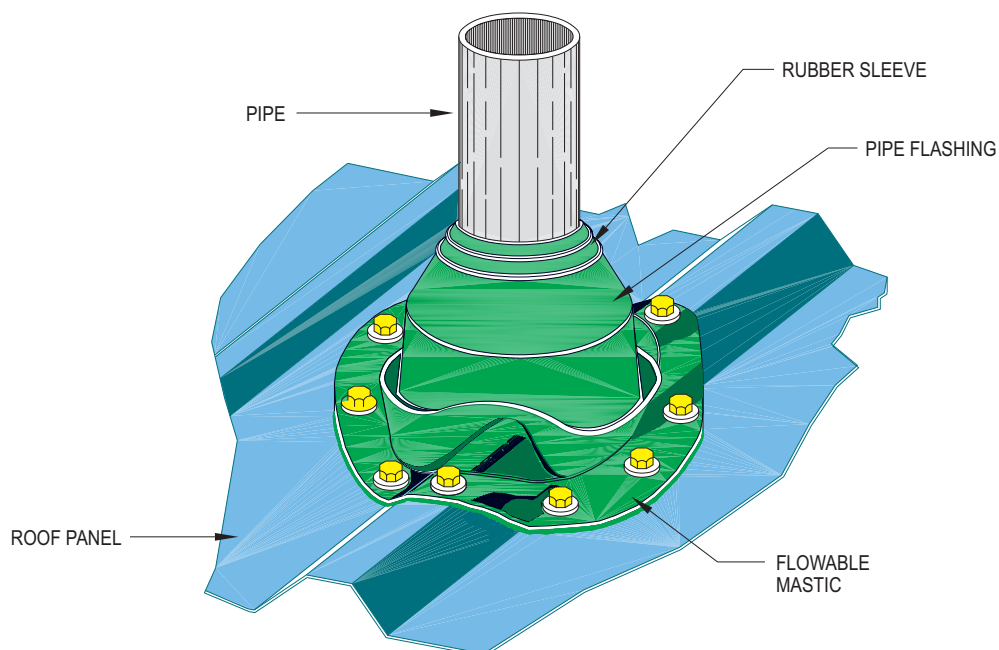



# SPECIAL BUYOUTS

# Special Buyouts

16.1	General .....	405
16.2	Examples .....	406

**Special Buyouts** are products that are supplied by Zamil Steel but are not manufactured by Zamil Steel. They are characterized by the following:

- They do not form a part of any product manufactured by Zamil Steel.
- They are not essential for producing a complete basic pre-engineered building.

**Standard Buyouts** are also products that are supplied by Zamil Steel but are not manufactured by Zamil Steel. They are characterized by the following:

- They form a part of a manufactured Zamil Steel product. Examples include door guides and door handles for sliding doors, mechanical ridge vent parts for gravity ridge ventilators, etc.
- They are essential for producing a complete basic pre-engineered building. Examples include connection bolts (including nuts & washers), self-drilling sheeting fasteners, foam closures, bead mastic, etc. Please refer to **chapter 15** on Sundry Parts.

Zamil Steel has a staff of two engineers totally dedicated to the supply of special buyouts. Since special buyouts are not stocked at Zamil Steel, they have to be ordered on a job by job basis. The special buyout engineers:

- Ensure that the technical specifications of the special buyouts (supplied by Zamil Steel) are in accordance with the contract documents.
- Ensure that the special buyouts are delivered to Zamil Steel factory in time to meet contractual delivery commitments.

- Coordinate with the Engineering Department to develop proper interface details to accommodate the special buyouts within the building shell.

Special buyouts are normally identified, described and priced separately in Zamil Steel's quotation offers since they are outside the scope of the basic building supply.

Special buyouts normally take a longer time to price and require longer delivery schedules as they fall outside the direct control of Zamil Steel. In many instances they are purchased from foreign sources in the United States or Europe.

**Examples of Special Buyouts include :**

- Fiberglass insulation
- Aluminum or steel louvers
- Aluminum windows
- Personnel doors
- Roll up doors (single skin or insulated)
- Power ventilators
- Fire rated doors of all types
- Crane systems (crane rails, crane bridge, bus bars, etc.)
- Aircraft hangar doors or hangar door operating systems
- Aluminum framing
- Glass
- Air-conditioning packages
- Demountable gypsum board partitions
- Suspended ceiling
- Insulated skylights
- Fiberglass roof curbs
- Wire mesh to retain roof insulation

# **SPECIALTY BUILDINGS**

C  
H  
A  
P  
T  
E  
R

17

# Specialty Buildings

17.1	General .....	409
17.2	Vehicle Parking Shelters .....	410
17.3	Service/Fuel Stations .....	418
17.4	Poultry Buildings .....	424
17.5	Bulk Storage Buildings .....	426
17.6	Aircraft Hangars .....	429



Zamil Steel classifies **specialty buildings** as pre-engineered buildings that are used in specific applications. They include:

- Vehicle Parking Shelters
- Automobile Service / Fuel Stations
- Poultry Farm Buildings
- Bulk Storage Sheds
- Aircraft Hangars

Standard designs and standard layouts for the above specialty buildings have been developed by Zamil Steel in view of the fact that the functional and aesthetic requirements for these buildings are often established by architects whose input is greatly influenced by a project's overall character and special requirements and/or by the environment surrounding these buildings.

Thus, in this chapter, we have attempted to demonstrate only the unique features attributed to each specialty building. These features can be used as basic ideas and guidelines for architects and designers in similar projects. The pre-engineered building system is flexible and can accommodate almost any architectural feature that can be conceived by the architect.



Outdoor **vehicle parking shelters** have become a common feature of commercial, industrial and residential developments throughout Asia and Africa. Because the structural integrity and aesthetic appearance of these parking shelters vary greatly (from the very basic to the exotic) depending on the structural design approach, material specifications and finishes, Zamil Steel has opted to create parking shelters that are engineered to structurally resist the specified loads (wind, earthquake, etc.) without sacrificing their aesthetic appearance.

The advantages of using pre-engineered steel buildings as vehicle parking shelters are:

- *Fewer columns.* Large bay lengths significantly reduce the number of columns needed, thus improving safety and utility.
- *Architectural versatility.* Appearances can be enhanced by using any of the following options:
  - Vertical or curved fascias
  - Flat, sculptured or profiled soffit panels
  - A variety of panel and trim profiles and colors
  - A wide range of special paint systems and custom colors for the primary and secondary structural members

- *Reliable structural design.* Like all Zamil Steel products, these shelters are designed in accordance with the latest applicable American codes (AISC, AISI, AWS, MBMA).
- *Quick delivery.*
- *Fast and simple erection.*

The standard parking shelter systems described in this section have been proven to be practical and durable, time after time, in hundreds of projects. Owners, architects and contractors need not be limited to these standards only; Zamil Steel standards are intended to serve as a starting point for developing specific project applications intended to satisfy the customer's most unique requirements.

**Note:** All “standard”, vehicle parking shelters are shown with recessed column base plates that are embedded beneath the finished floor level. The shelters are supplied with roof sheeting, gable and eave trim.

All column base plan dimensions shown are not for construction. Final dimensions are shown in the anchor bolt plans issued for construction by Zamil Steel.

Gazelle

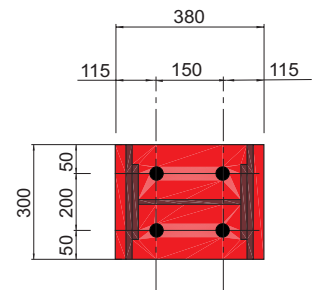
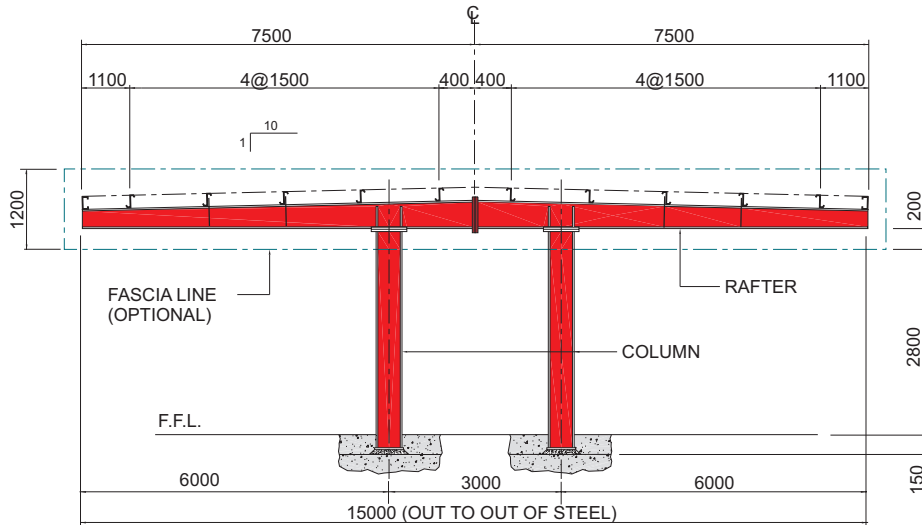

**COLUMN BASE PLAN**  
(Column recessed 150mm below F.F.L.)

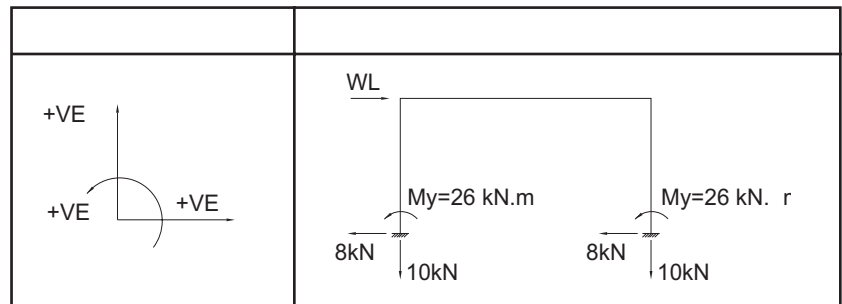
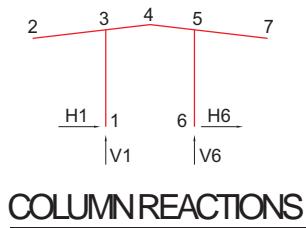

Bay Length = 6 m<sup>+</sup>  
 Dead Load = 0.10 kN/m<sup>2</sup>  
 Live Load = 0.57 kN/m<sup>2</sup>  
 Wind Speed = 130 km/h

\* FOR 9 m BAY LENGTHS MULTIPLY THE ABOVE COLUMN REACTIONS BY 1.50

LOAD COMBINATION	COLUMN REACTIONS				FRAME ON GRID LINE
	V1 (kN)	H1 (kN)	V6 (kN)	H6 (kN)	
DEAD + LIVE	40	-15	40	15	ALL
DEAD LOAD ONLY	10	-5	10	5	"
DEAD + LIVE (1/2 SPAN)	-15	-10	55	10	"
DEAD + 2 kN AT EDGE	20	-5	10	5	"
DEAD + WIND (CASE I) *	-25	-5	5	-10	"
DEAD + WIND (CASE II) *	-35	-5	25	-10	"

\* Wind load cases I and II are two different methods of applying wind load to the structure as per the 1996 Edition of the "Low Rise Building Systems Manual" published by MBMA.

**Cheetah**

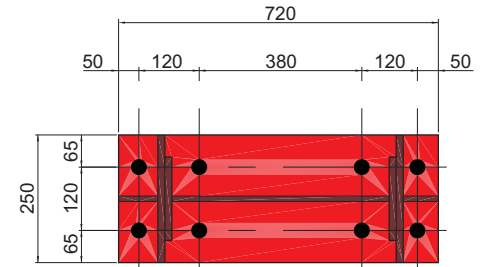
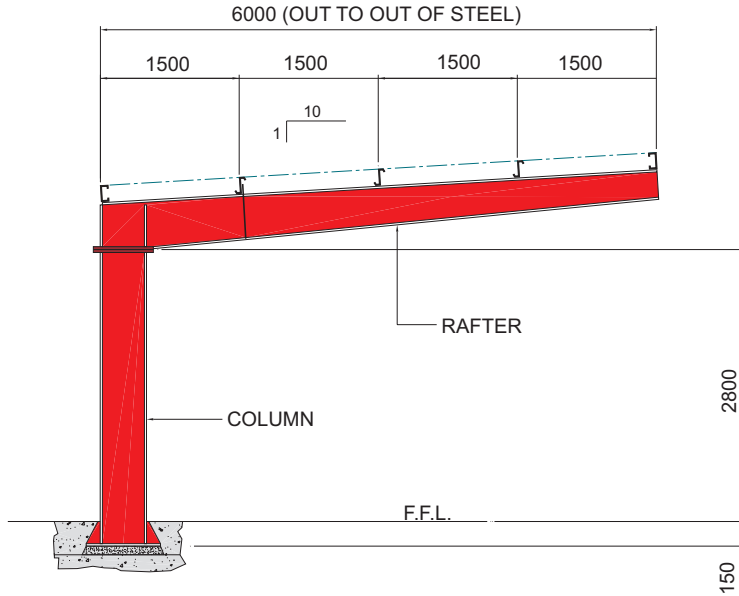

**COLUMN BASE PLAN**  
(Column recessed 150mm below FFL)

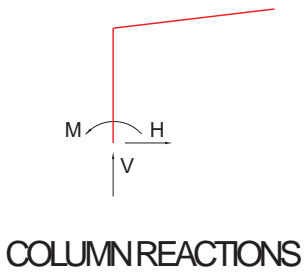

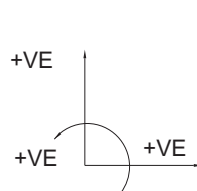
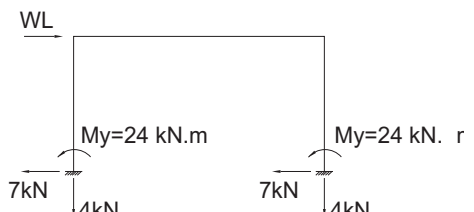
SIGN CONVENTION	BRACING REACTIONS
	

- Bay Length = 6 m<sup>+</sup>
- Dead Load = 0.10 kN/m<sup>2</sup>
- Live Load = 0.57 kN/m<sup>2</sup>
- Wind Speed = 130 km/h

LOAD COMBINATION	COLUMN REACTIONS			FRAME ON GRID LINE
	V (kN)	H (kN)	M (kN.m)	
DEAD + LIVE	35	0	86	ALL
DEAD + 2 kN AT EDGE	15	0	29	"
DEAD + WIND (RIGHT)	-5	15	-52	"
DEAD + WIND (LEFT)	-5	-10	17	"
DEAD LOAD ONLY	15	0	29	"

\* FOR 9 m BAY LENGTHS MULTIPLY THE ABOVE COLUMN REACTIONS BY 1.50

Falcon I

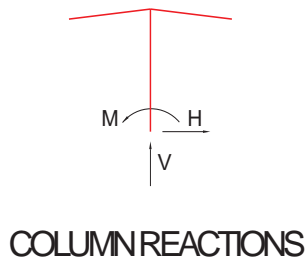
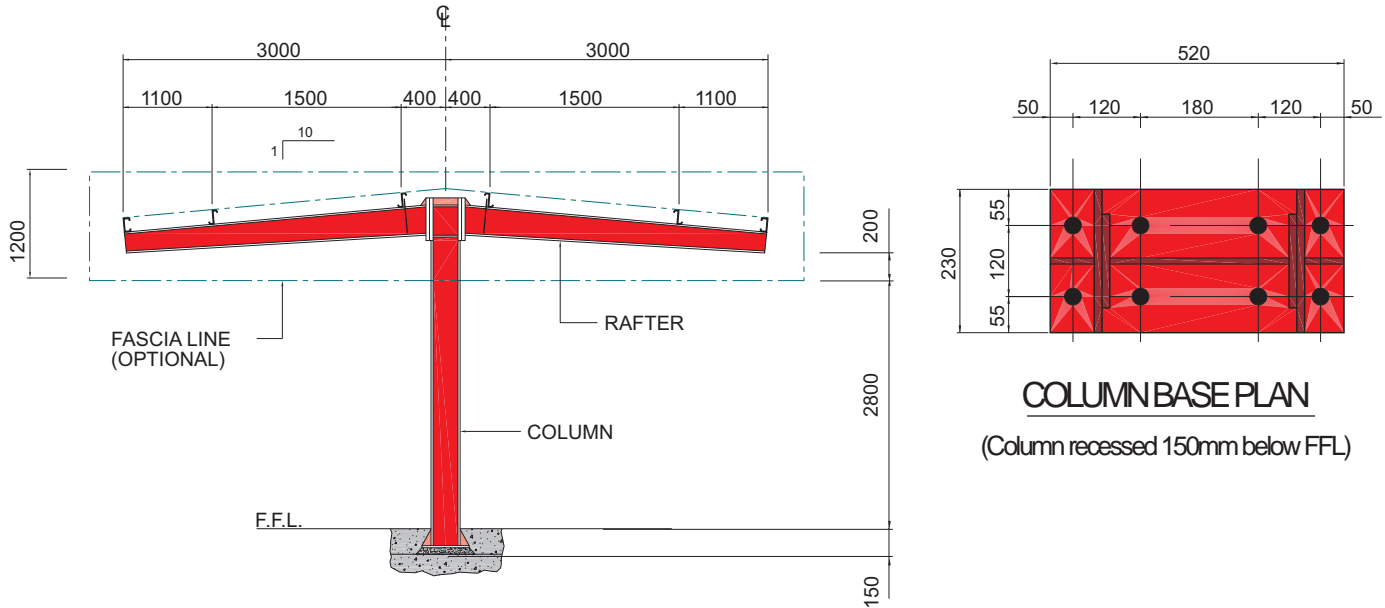

SIGN CONVENTION	BRACING REACTIONS

- Bay Length = 6 m<sup>+</sup>
- Dead Load = 0.10 kN/m<sup>2</sup>
- Live Load = 0.57 kN/m<sup>2</sup>
- Wind Speed = 130 km/h

\* FOR 9 m BAY LENGTHS MULTIPLY THE ABOVE COLUMN REACTIONS BY 1.50

LOAD COMBINATION	COLUMN REACTIONS			FRAME ON GRID LINE
	V (kN)	H (kN)	M (kN.m)	
DEAD + LIVE (FULL SPAN)	35	0	0	ALL
DEAD + LIVE (1/2 SPAN)	25	0	16	"
DEAD + 2 kN AT EDGE	15	0	6	"
DEAD + WIND (CASE I) *	-5	-10	33	"
DEAD + WIND (CASE II) *	5	-10	41	"
DEAD LOAD	15	0	0	"

\* Wind load cases I and II are two different methods of applying wind load to the structure as per the 1986 Edition / 1990 Supplement of the "Low Rise Building Systems Manual" of MBMA.

### Falcon II

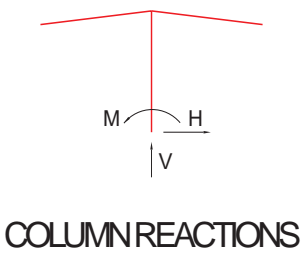
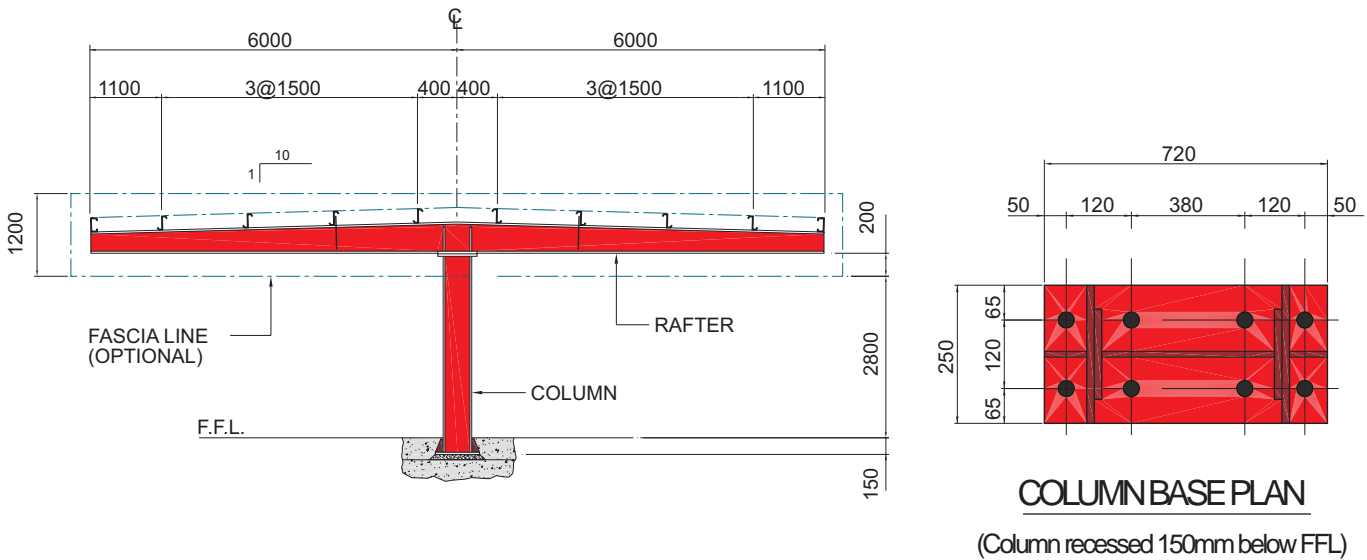

SIGN CONVENTION	BRACING REACTIONS

- Bay Length = 6 m<sup>+</sup>
- Dead Load = 0.10 kN/m<sup>2</sup>
- Live Load = 0.57 kN/m<sup>2</sup>
- Wind Speed = 130 km/h

<sup>+</sup> FOR 9 m BAY LENGTHS MULTIPLY THE ABOVE COLUMN REACTIONS BY 1.50

LOAD COMBINATION	COLUMN REACTIONS			FRAME ON GRID LINE
	V (kN)	H (kN)	M (kN.m)	
DEAD + LIVE (FULL SPAN)	60	0	0	ALL
DEAD + LIVE (1/2 SPAN)	40	0	62	"
DEAD + 2 kN AT EDGE	25	0	12	"
DEAD + WIND (CASE I) *	-15	-10	33	"
DEAD + WIND (CASE II) *	-10	-10	65	"
DEAD LOAD	20	0	0	"

\* Wind load cases I and II are two different methods of applying wind load to the structure as per the 1996 Edition of the "Low Rise Building Systems Manual" published by MBMA.

Butterfly I

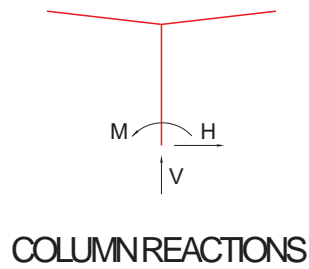
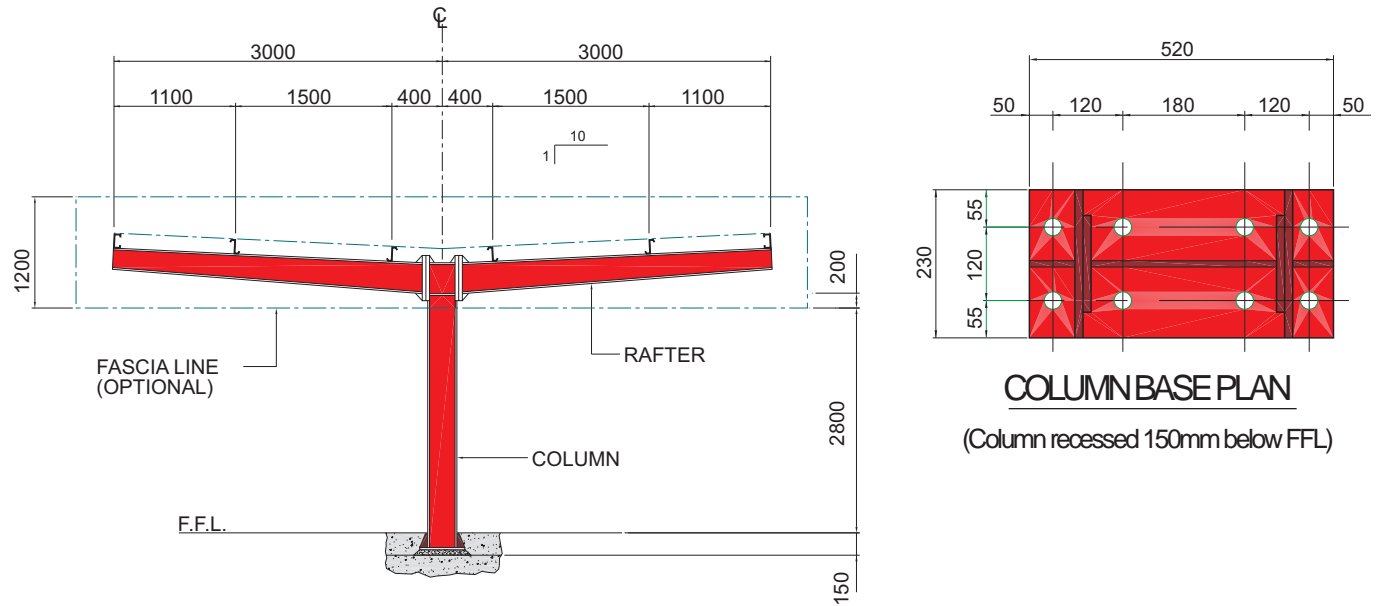

SIGN CONVENTION	BRACING REACTIONS

- Bay Length = 6 m<sup>+</sup>
- Dead Load = 0.10 kN/m<sup>2</sup>
- Live Load = 0.57 kN/m<sup>2</sup>
- Wind Speed = 130 km/h

\* FOR 9 m BAY LENGTHS MULTIPLY THE ABOVE COLUMN REACTIONS BY 1.50

LOAD COMBINATION	COLUMN REACTIONS			FRAME ON GRID LINE
	V (kN)	H (kN)	M (kN.m)	
DEAD + LIVE (FULL SPAN)	35	0	0	ALL
DEAD + LIVE (1/2 SPAN)	25	0	16	"
DEAD + 2 kN AT EDGE	15	0	6	"
DEAD + WIND (CASE I) *	-5	-10	37	"
DEAD + WIND (CASE II) *	5	-10	46	"

\* Wind load cases I and II are two different methods of applying wind load to the structure as per the 1996 Edition of the "Low Rise Building Systems Manual" published by MBMA.

### Butterfly II

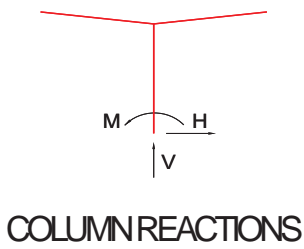
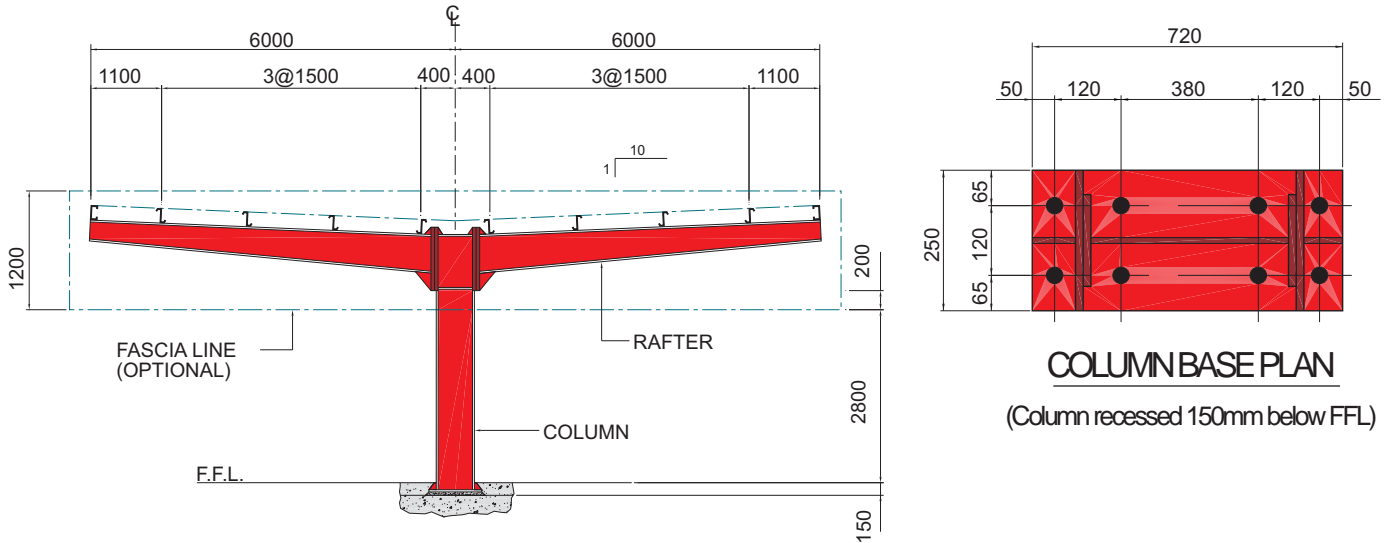

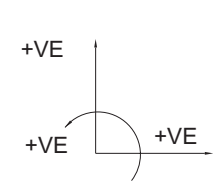
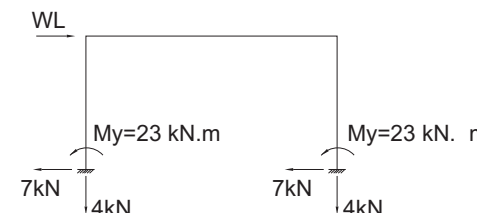
SIGN CONVENTION	BRACING REACTIONS
	

- Bay Length = 6 m<sup>+</sup>
- Dead Load = 0.10 kN/m<sup>2</sup>
- Live Load = 0.57 kN/m<sup>2</sup>
- Wind Speed = 130 km/h

\* FOR 9 m BAY LENGTHS MULTIPLY THE ABOVE COLUMN REACTIONS BY 1.50

LOAD COMBINATION	COLUMN REACTIONS			FRAME ON GRID LINE
	V (kN)	H (kN)	M (kN.m)	
DEAD + LIVE (FULL SPAN)	65	0	0	ALL
DEAD + LIVE (1/2 SPAN)	45	0	62	"
DEAD + 2 kN AT EDGE	25	0	12	"
DEAD + WIND (CASE I)*	-10	-10	41	"
DEAD + WIND (CASE II) *	-5	-15	77	"
DEAD LOAD ONLY	25	0	0	"

\* Wind load cases I and II are two different methods of applying wind load to the structure as per the 1996 Edition of the "Low Rise Building Systems Manual" published by MBMA.



Caracal

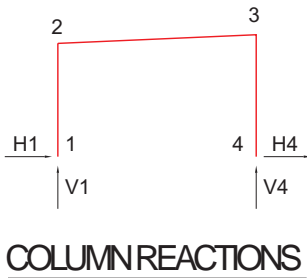
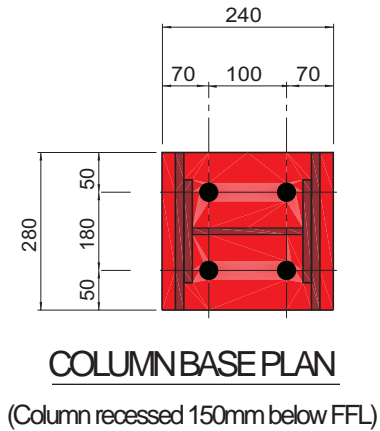
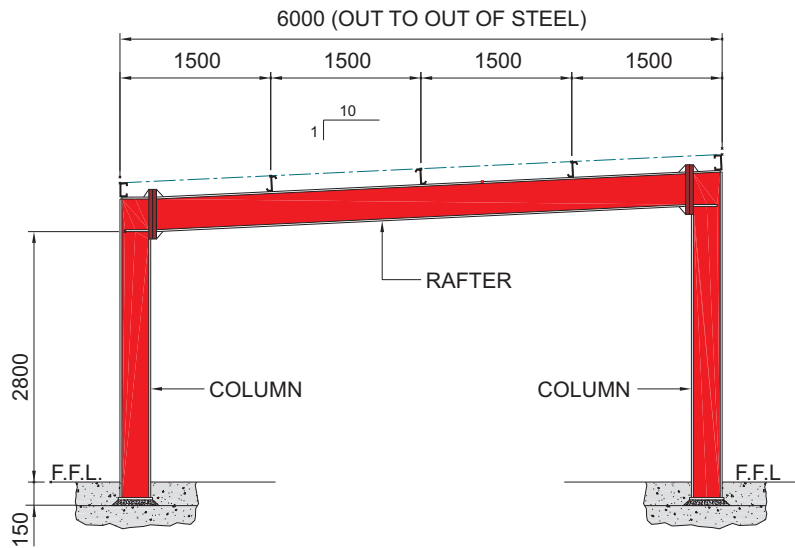

SIGN CONVENTION	BRACING REACTIONS

Bay Length = 6 m<sup>+</sup>  
 Dead Load = 0.10 kN/m<sup>2</sup>  
 Live Load = 0.57 kN/m<sup>2</sup>  
 Wind Speed = 130 km/h

LOAD COMBINATION	COLUMN REACTIONS				FRAME ON GRID LINE
	V1 (kN)	H1 (kN)	V4 (kN)	H4 (kN)	
DEAD + LIVE	20	5	20	-5	ALL
DEAD + WIND (LEFT)	-10	-10	10	-5	“
DEAD + WIND (RIGHT)	10	10	-10	10	“
DEAD LOAD ONLY	10	5	10	-5	“

\* FOR 9 m BAY LENGTHS MULTIPLY THE ABOVE COLUMN REACTIONS BY 1.50

The use of pre-engineered structures for vehicle **service / fuel stations** is very common in the U.S.A. and the Middle East where the pre-engineered building system has historically dominated the single storey non-residential construction market.

The distinguishing features of Zamil Steel service stations are:

- *Tubular columns* that provide a more aesthetic structural appearance
- *Flat soffits* that aesthetically accent the underside of the roof structure
- *Vertical fascias*

The systems described in the following pages have proven to be efficient and economical and are offshoots of the clear span vehicle shelters, described in **section 17.2** of this chapter. These service/fuel stations typically have a better standard of aesthetic

finish reflecting their more demanding commercial requirements.

Other architectural features can be incorporated to further enhance the appearance of these structures.



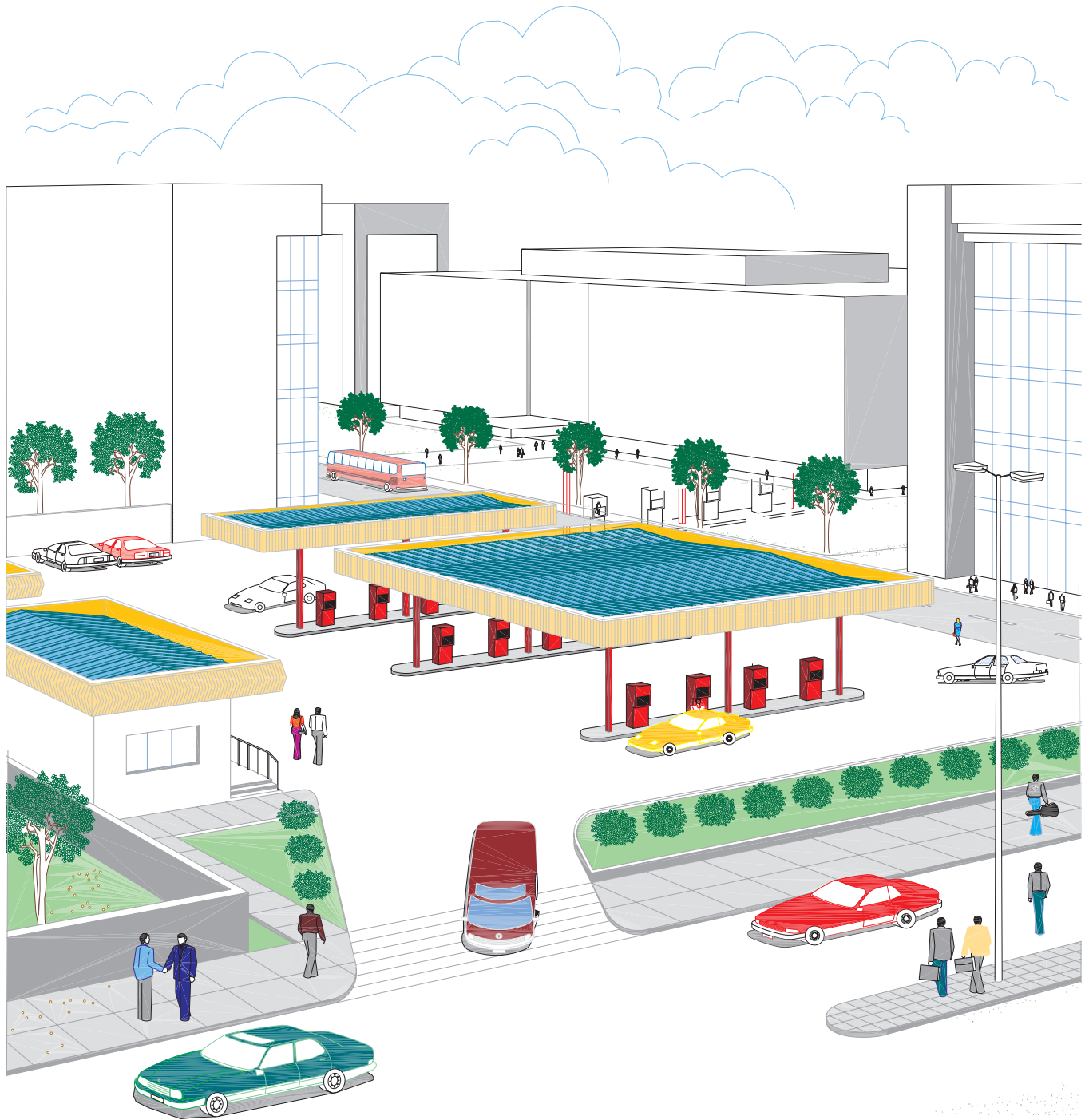

PERSPECTIVE : SERVICE/FUEL STATIONS

**Type I**

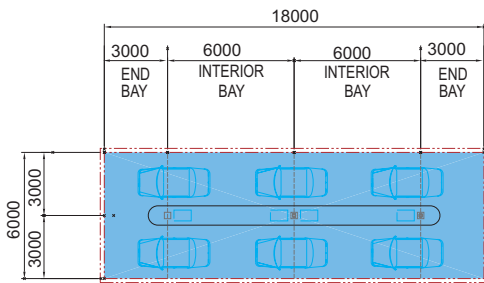
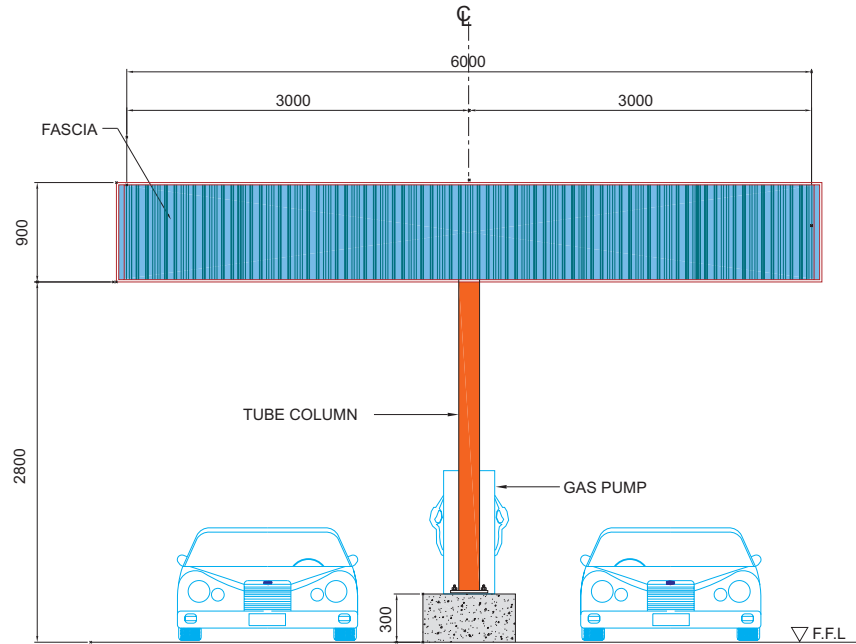

**PLAN**

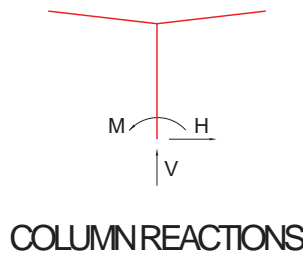

**COLUMN REACTIONS**

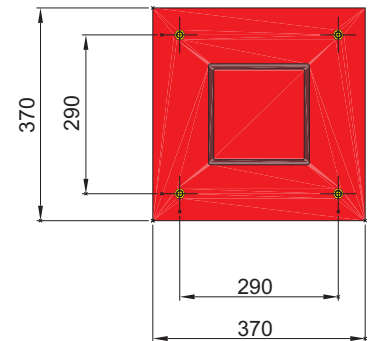

**COLUMN BASE PLAN**

- Bay Length = 6 m
- Dead Load = 0.10 kN/m<sup>2</sup>
- Live Load = 0.57 kN/m<sup>2</sup>
- Wind Speed = 130 km/h

LOAD COMBINATION	COLUMN REACTIONS			FRAME ON GRID LINE
	V (kN)	H (kN)	M (kN.m)	
DEAD + LIVE (FULL)	32	0	0	ALL
DEAD + LIVE (1/2 SPAN)	22	0	-16	"
DEAD + 2 kN	13	0	-6	"
DEAD + WIND (SIDE)	-5	-8	27	"
DEAD ONLY	12	0	0	"

Type II

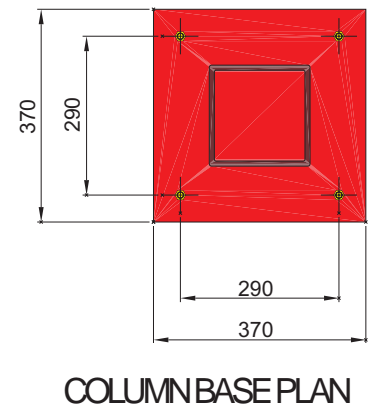
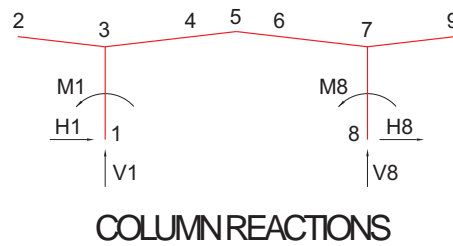
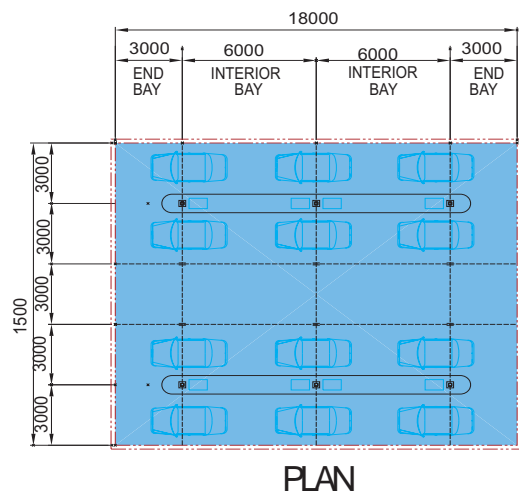
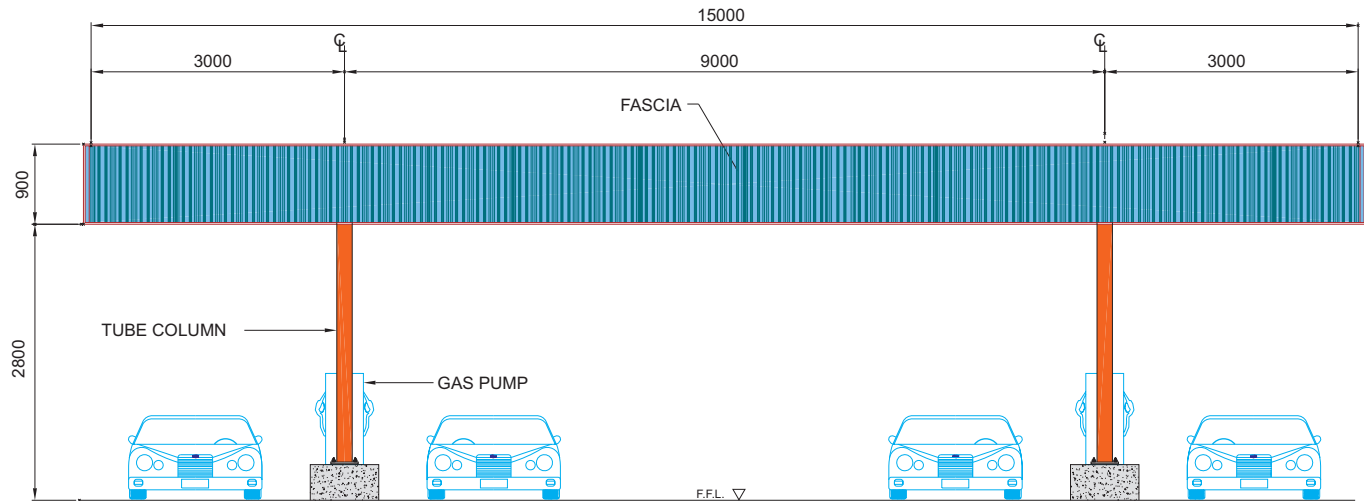

- Bay Length = 6 m
- Dead Load = 0.10 kN/m<sup>2</sup>
- Live Load = 0.57 kN/m<sup>2</sup>
- Wind Speed = 130 km/h

LOAD COMBINATION	COLUMN REACTIONS						FRAME ON GRID LINE
	V1 (kN)	H1 (kN)	V8 (kN)	H8 (kN)	M1 (kN.m)	M8 (kN.m)	
DEAD + LIVE (FULL)	37	3	37	-3	-4	4	ALL
DEAD + LIVE (1/2 SPAN)	34	2	13	-2	-3	2	"
DEAD + 2 kN	13	-2	10	2	1	-2	"
DEAD + WIND (SIDE)	-11	-2	-11	-2	4	-4	"
DEAD ONLY	11	-1	11	1	1	-1	"

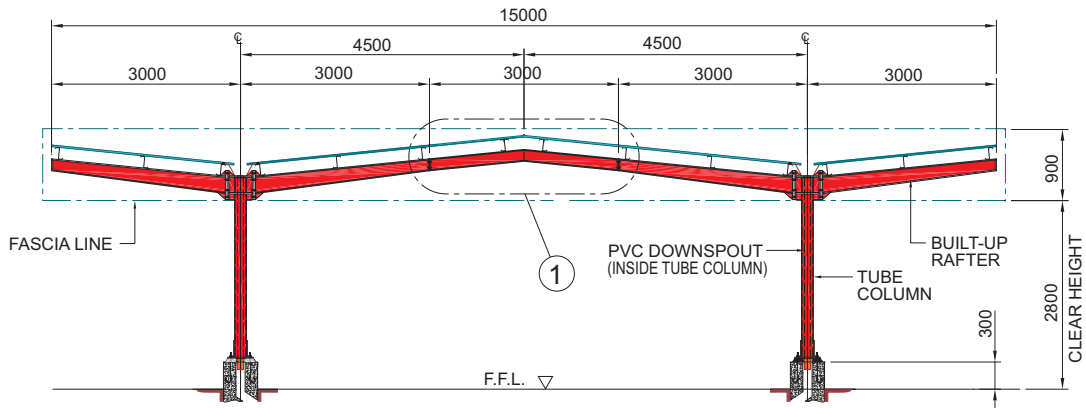

**ELEVATION** : SERVICE/FUEL STATION STRUCTURAL DETAILS

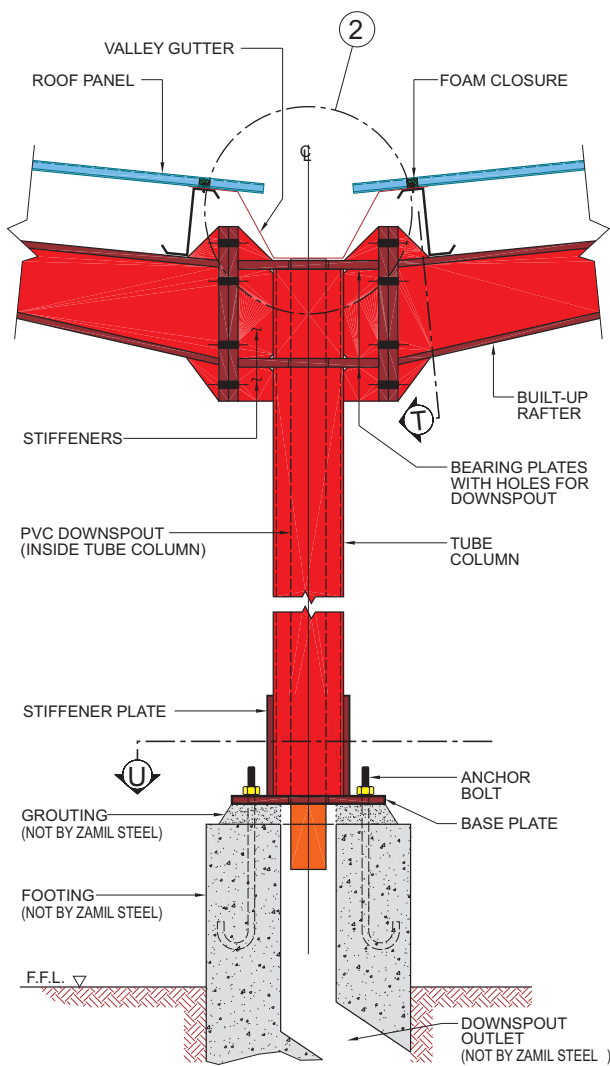

**DETAIL OF COLUMN/RAFTER**

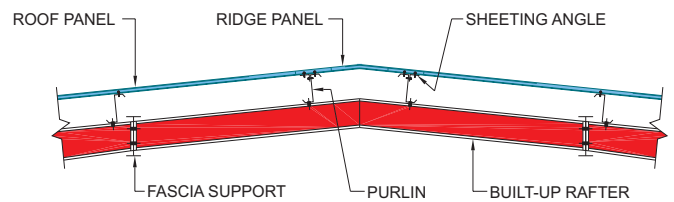

**DETAIL-1**

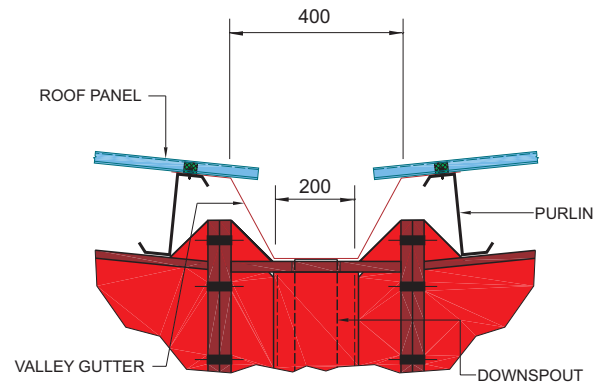

**DETAIL-2**

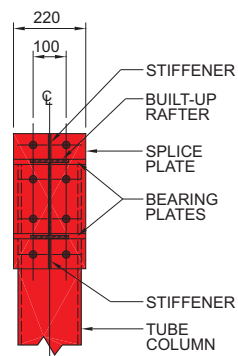

**SECTION-T**

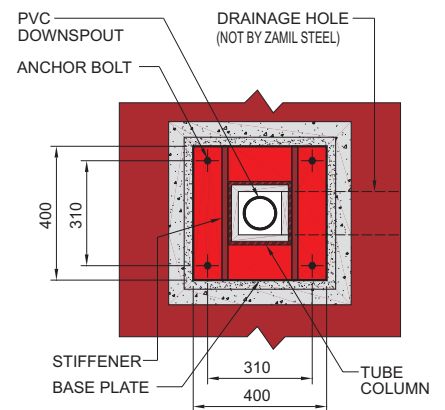

**SECTION-U**

**DETAILS: GENERAL STRUCTURAL**

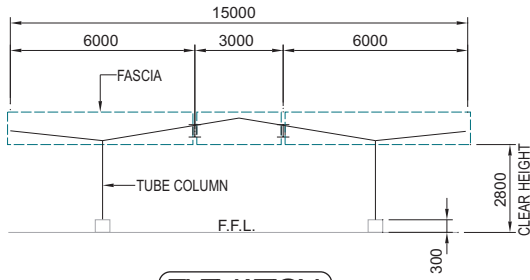

ELEVATION

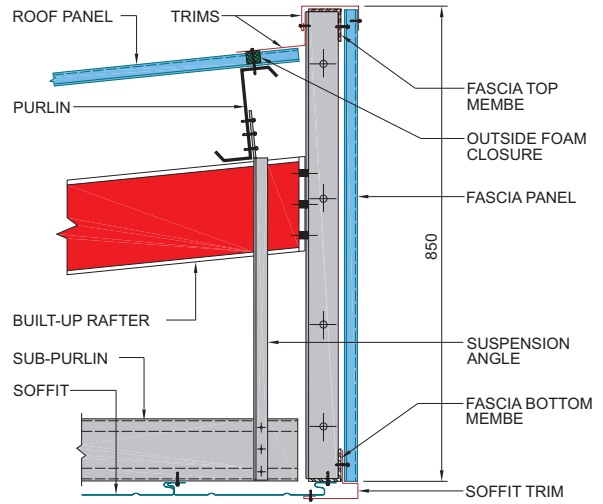

SECTION L : WITH STD. FASCIA PANEL

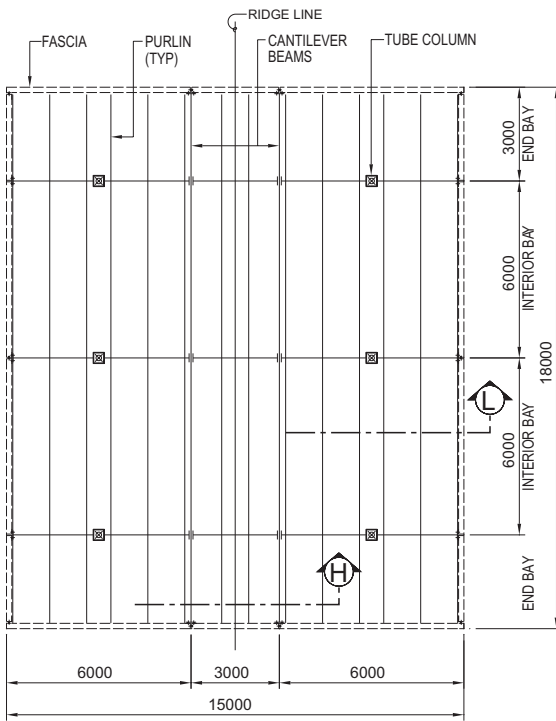

PLAN

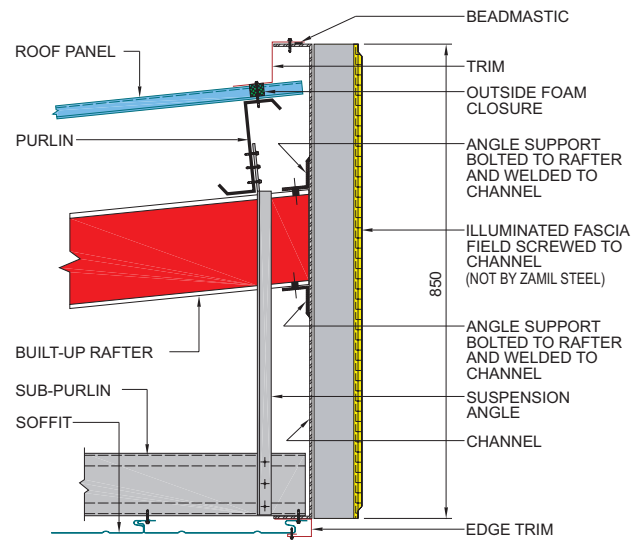

SECTION L : WITH ILLUMINATED FASCIA

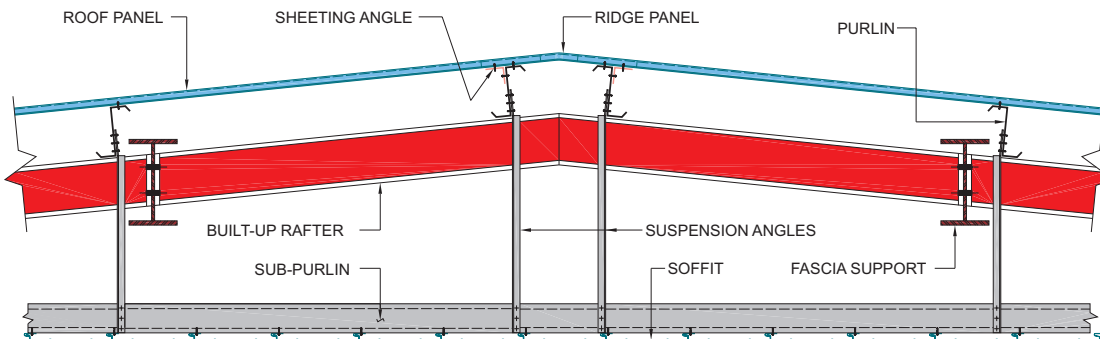

SECTION H

DETAILS: ROOF FRAMING AND FASCIA DETAILS

Poultry buildings are used as rearing houses, broiler houses, laying houses and for any other poultry farm application.

The high cost of livestock and equipment demands that dependable, quality built structures protect the owner's investment. Special care must be taken to protect the steel from the corrosive environment generated inside the buildings as well as from harsh external weather conditions. Maintenance costs for Zamil Steel's poultry buildings are minimal; this is an important factor to consider when evaluating the initial purchase price of a poultry building.

These Zamil Steel buildings were developed specifically for the poultry industry and are designed to accommodate the equipment and ventilation systems normally required for this specific application. The buildings may also be configured to meet other requirements.

The features provided in a standard Zamil Steel poultry building result in functional and durable structures such as noted below.

Feature	Description
Galvanized structural steel members	This premium coating for the structural members protects the structure against the high moisture content and the corrosive nature of the materials normally present in poultry buildings.
Galvanized steel or aluminum panels	These panel options provide the optimum corrosion resistance and protection needed for these buildings.
Electrogalvanized connection machine bolts	Electrogalvanized bolts with yellow Dacromet conversion coatings for corrosion protection.
Corrosion resistant panel fasteners	Rust resistant plated and dichromate dipped screws with a neoprene weather seal under the washer firmly attach the roof and wall panel to the steel framing.
Fiberglass insulation	A 100 mm thick vinyl faced fiberglass blanket helps to maintain the desired temperature inside.
Weather tight neoprene closure strips	Tight fitting profiled closures, matching the ribs of roof and wall panels, provide a secured building against intrusion by rodents and enhance the efficiency of the building insulation.



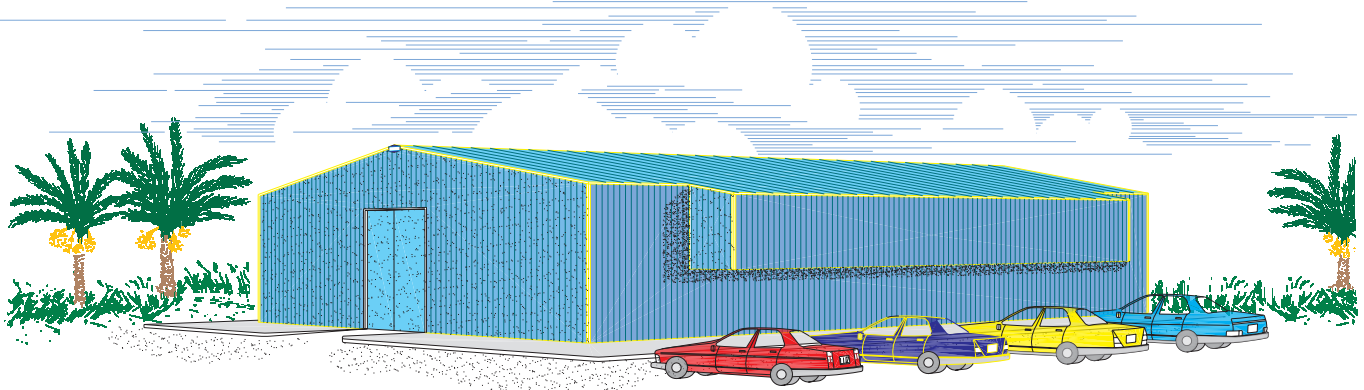

**PERSPECTIVE** : TYPICAL POULTRY BUILDING

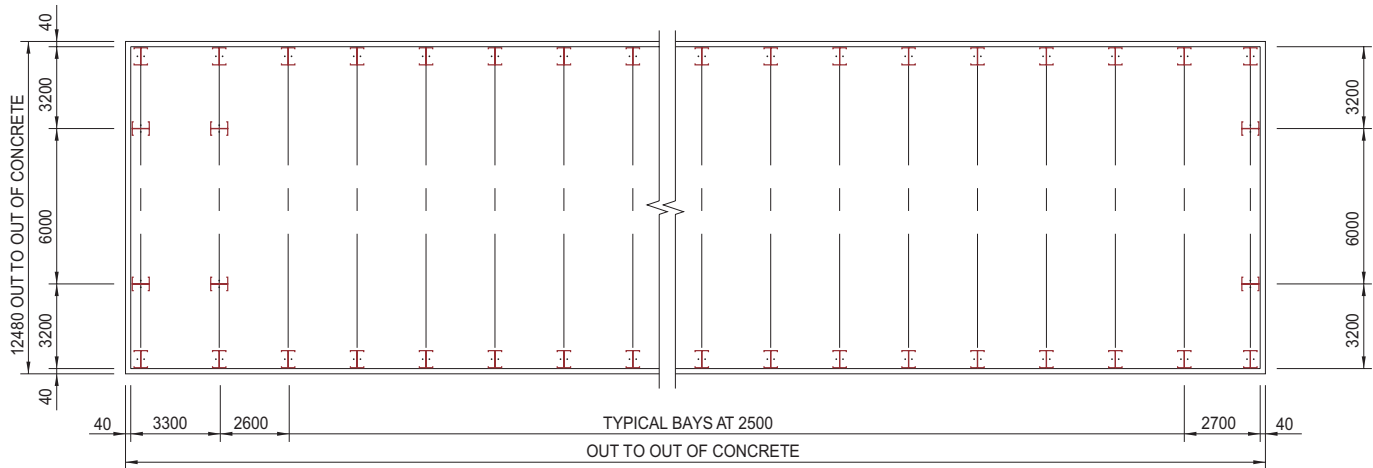

**PLAN** : ANCHOR BOLT SETTING

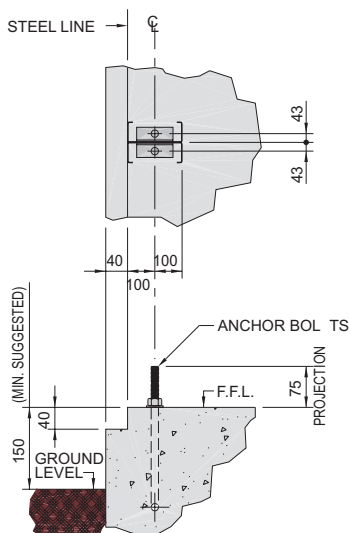

**DETAIL** : AT COLUMN BASE

SIGN CONVENTION	BRACING REACTIONS	NOTE: ALL REACTIONS ARE SHOWN IN KILONEWTONS. ARROWS INDICATE POSITIVE DIRECTION OF LOADS AND REACTIONS.

LOAD COMBINATION	REACTIONS				FRAME ON GRID LINE
	V1 (kN)	H1 (kN)	V4 (kN)	H4 (kN)	
DEAD + LIVE	9	4	7	-4	ALL
DEAD + WIND	-3	-5	-2	-1	ALL

**Bulk storage buildings** for granular materials such as, wheat, sugar, cement, etc. require special engineering considerations. The angle of repose (which is the maximum stable natural slope that a specific material can assume) and the required storage capacity are factors that influence the geometry and design of the bulk storage building.

The *pressure* that granular material exerts on the bearing walls is a function of the material height, unit weight and angle of internal friction. The table below lists these properties for different granular materials.

Bulk storage buildings are normally Clear Span buildings characterized by a steep roof slope that permits the efficient storage of piled granular material above the building eave height.

If the interior metal walls are required to resist the horizontal pressure of the granular material, an adequate wall liner panel must be provided to

transfer this load to the wall girts and, in turn, to the rigid frame columns.

For chemically active materials, it is recommended to consider wall surface finishes other than steel liner panels. Alternatively, the building geometry may be configured in such a way so as to ensure that the granular material piles away from the wall. Another common approach is to have a reinforced concrete wall up to a height, “h” (see page 3 of 3 of this section), to avoid direct loads on the steel structure from the granular material.

Mechanical subsystems, such as cranes, conveyor belts and walkways can be easily accommodated within these buildings.

When required, Zamil Steel can provide structural members that are shot-blasted and painted with premium paint systems to meet the demanding requirements of hygienic sanitation.

Material	Angle of Internal Friction *(Degrees)	Angle of Repose (Degrees)	Unit Weight (kN/m <sup>3</sup> )
Wheat	26	25	8.8
Maize	26	25	8.1
Barley	31	25	7.4
Oats	33	25	5.9
Rye	29	24	7.6
Corn	35	32	7.6
Peas	34	30	7.5
Beans	33	27	8.4
Flour	—	40	4.4
Sugar	—	35	10.0
Coal	35	35	9.1
Ashes	35	45	7.1
Cement	10	15	14.1
Lime	—	35	10.0

\* When the angle of internal friction is not available, the angle of repose can be used for pressure calculations.

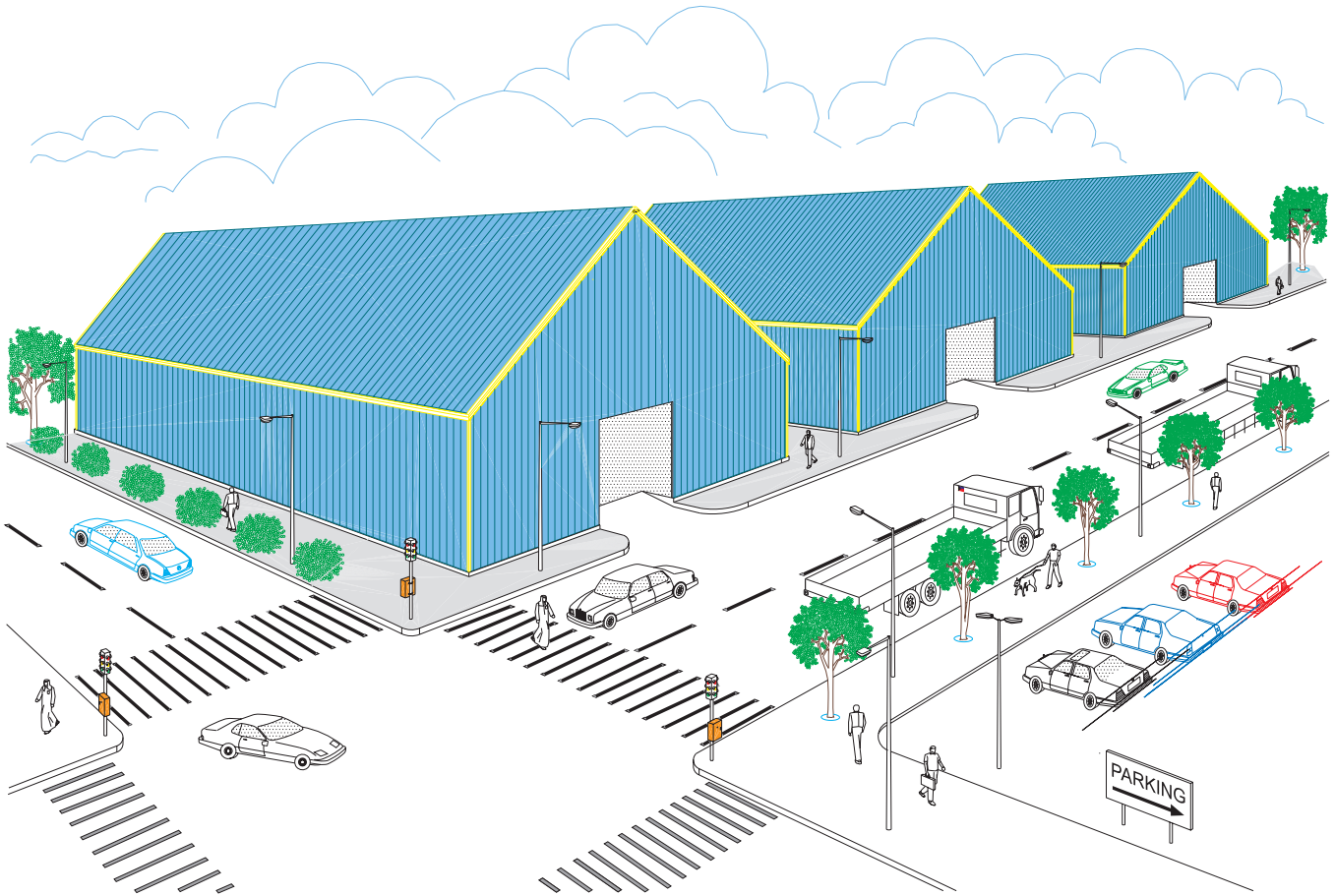

PERSPECTIVE : BULK STORAGE BUILDINGS

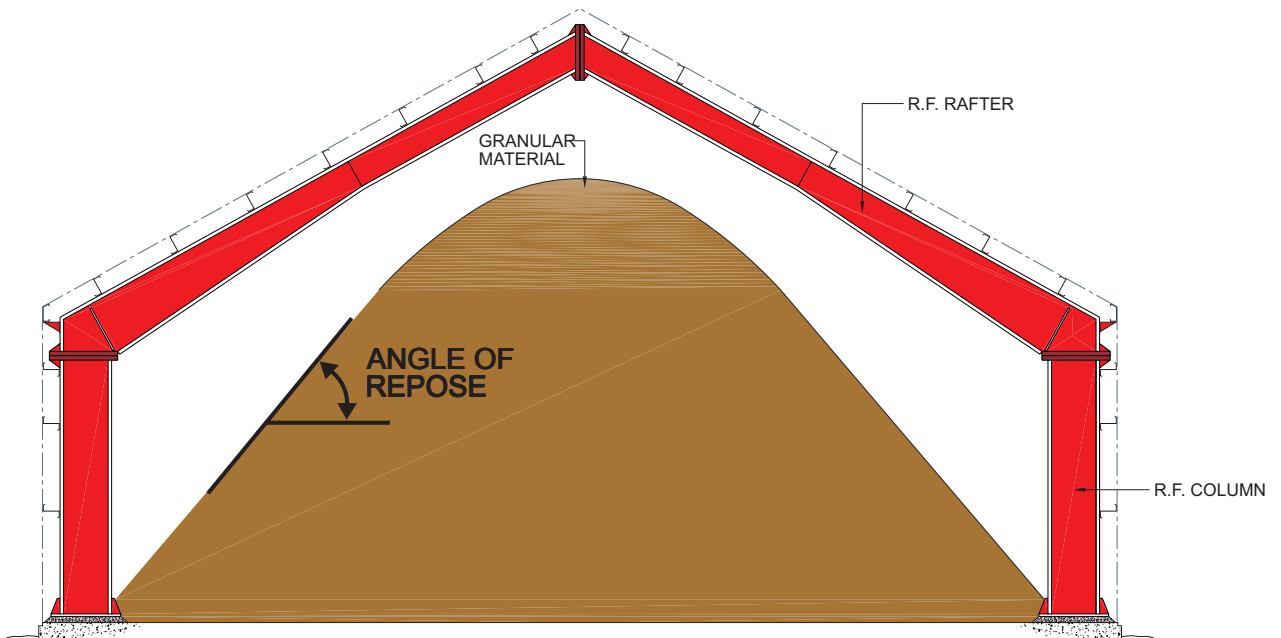

SECTION : TYPICAL BULK STORAGE BUILDING

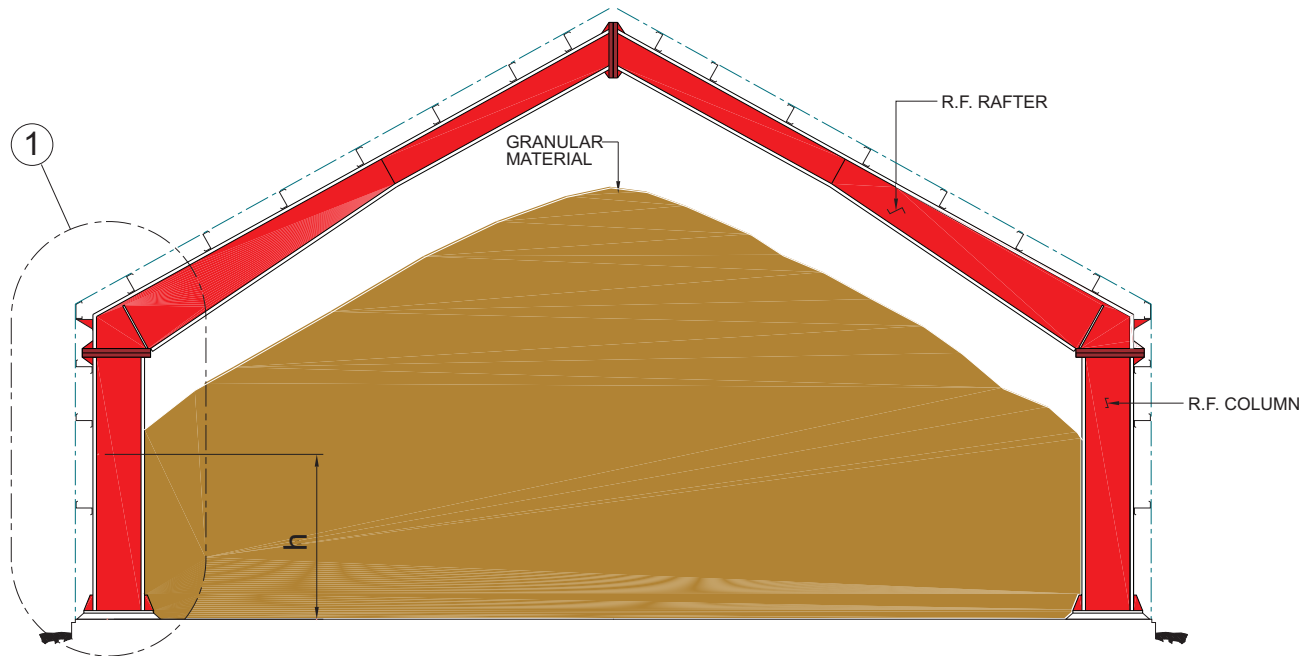

**SECTION** : BULK STORAGE BUILDING WITH SIDEWALL PRESSURE

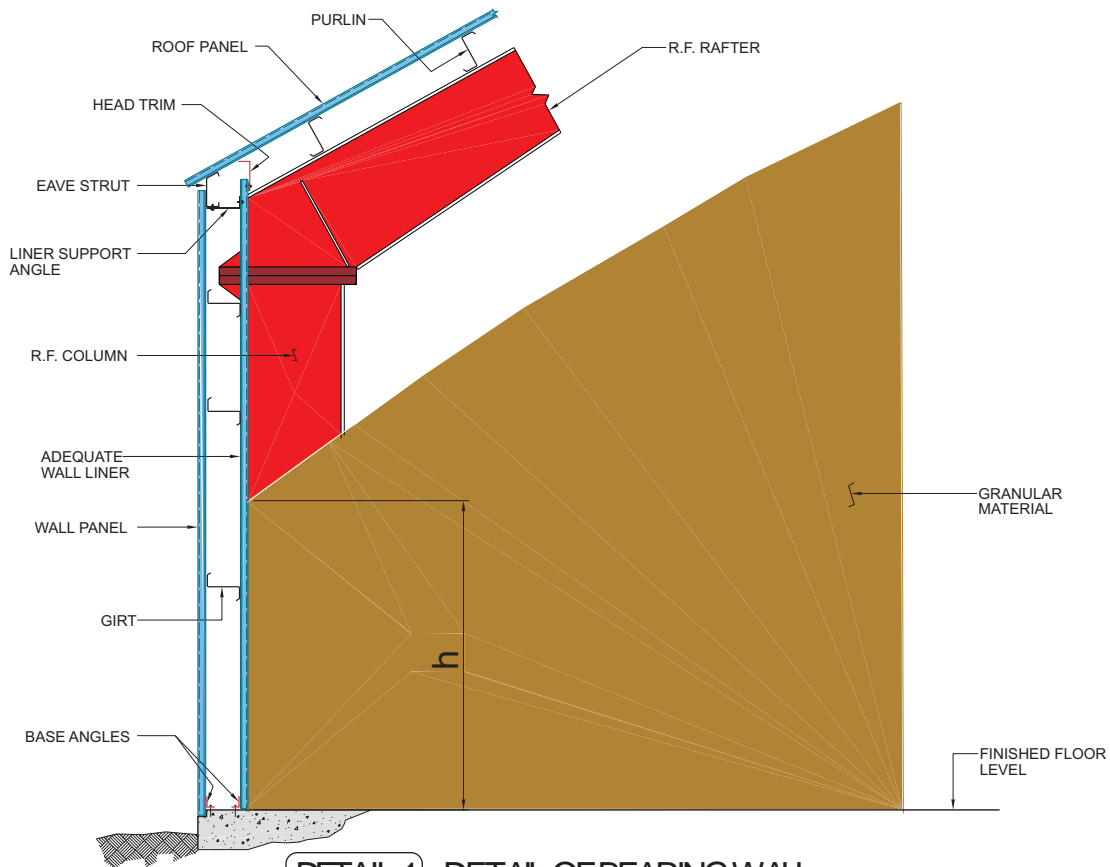

**DETAIL-1** : DETAIL OF BEARING WALL

Pre-engineered steel buildings are often used to shelter and/or maintain commercial, civilian and military aircraft.

### Hangar Building Structures

Aircraft hangar buildings are characterized by large clear span widths (ranging from 48 m to 96 m) and very high eave heights (ranging between 24 m and 36 m).

Pre-engineered buildings can be efficiently utilized for building widths up to 84 m. For wider spans, structural steel truss systems become more practical. Zamil Steel's expertise in hangar buildings extends beyond the use of only pre-engineered buildings. Zamil Steel has designed, manufactured and supplied spans up to 96 m for aircraft hangar buildings using structural trusses.

The following pages are intended to illustrate typical details incorporated in hangar buildings using the pre-engineered building approach. Actual building details may differ depending on the specific requirements of the project and the actual live load, wind load, collateral loads, deflection criteria, etc. that are specified. The dimensions of aircraft shown are intended as a guide only; owners should contact aircraft manufacturers to verify these dimensions for their specific requirements.



### Hangar Doors

A hangar door typically consists of several electrically controlled steel framed door leaves which telescope into covered **pockets** on one side or both sides of the building. The weight of a hangar door is supported on wheels traveling on a steel rail that is recessed below the finished floor level.

The design of a hangar door is a complex exercise and is considered as a major input in the design of a hangar building. Furthermore, since the supporting system of the hangar door is an integral part of the main structure of the building, the system must be considered in the structural analysis and design of the complete building. Zamil Steel recommends that hangar doors be ordered directly from a specialized hangar door manufacturer who will be responsible for coordinating the design and interface of the door with the Zamil Steel Engineering Department.

Wind load and gravity load deflections are major factors in the design of a building with a hangar door. Deflection values of the supporting frames of the door are extremely important and must be defined to the door manufacturer as they represent an important design input for the hangar door. Vertical end frame deflection is normally limited to a maximum of 100 mm.

The insulation of the hangar door, the exterior wall panel and the interior wall liner panel are normally supplied by Zamil Steel in order to match the color and profile of the exterior wall panel of the building.

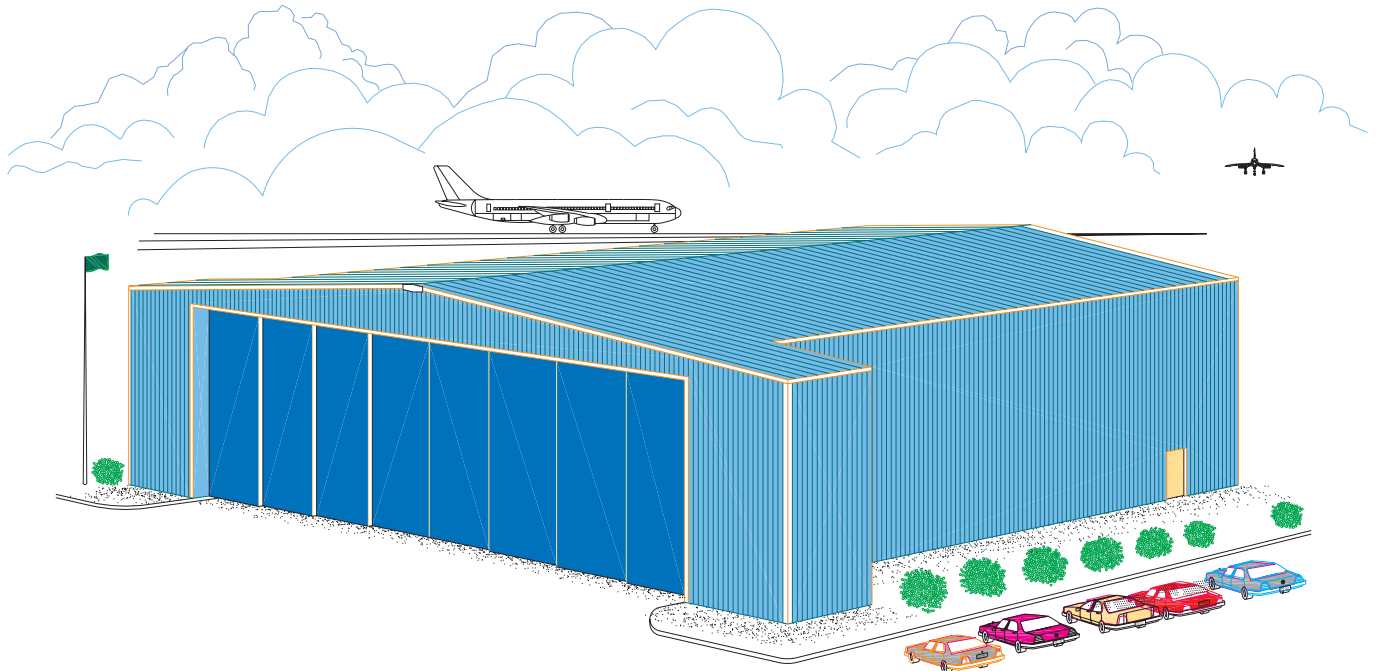

PERSPECTIVE

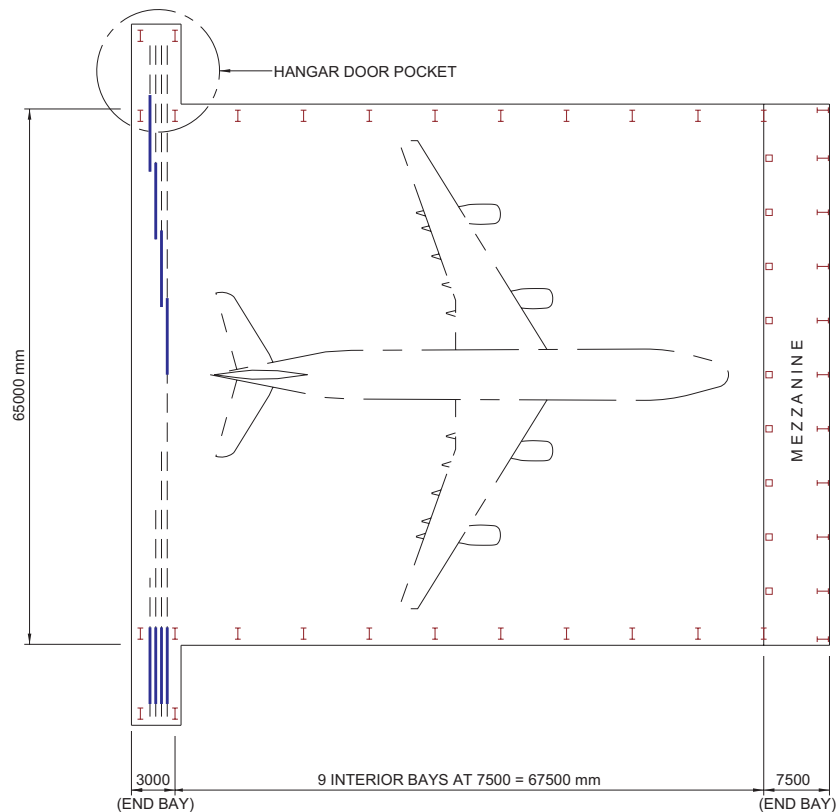

PLAN : AIRCRAFT HANGAR WITH EXAMPLE DIMENSIONS

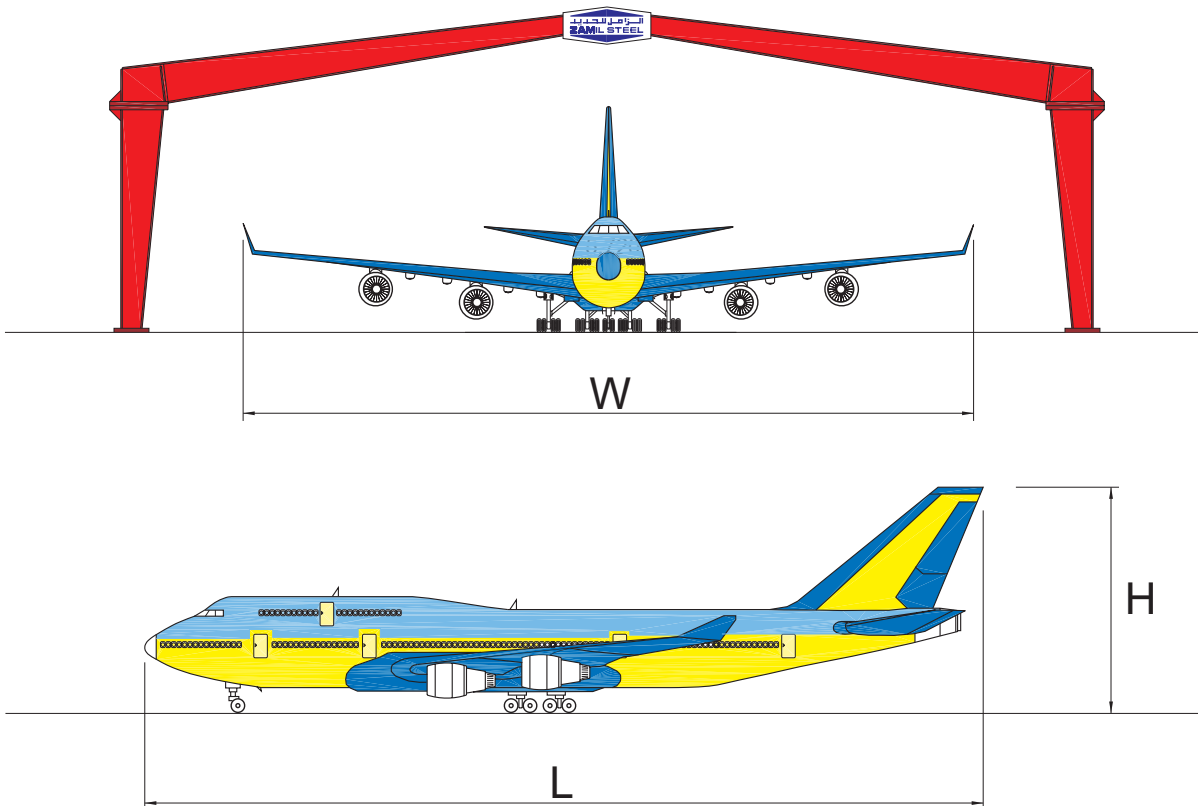

TYPE OF AIRCRAFT	W (WING SPAN)	L (OVERALL LENGTH)	H (OVERALL HEIGHT)
BOEING 727-200	32.920	46.680	8.660
BOEING 737-500	28.890	29.790	8.660
BOEING 747-400 COMBI	64.940	68.600	19.580
BOEING 757-200	38.049	47.320	13.564
BOEING 767-300	47.574	54.940	15.849
AIRBUS A340-200	58.640	59.422	16.918
AIRBUS A340-300	60.304	63.658	16.828
McDONNELL-DOUGLAS DC-8-70	45.237	57.125	12.929
McDONNELL-DOUGLAS DC-9-80	32.850	45.020	9.200
McDONNELL-DOUGLAS DC-10	50.394	55.499	17.704
FALCON 900	19.330	19.550	7.550
LOCKHEED C-5A GALAXY	67.882	75.540	19.850
LOCKHEED C-130 HERCULES	40.411	29.794	11.659
LOCKHEED C-141 STARLIFTER	48.743	51.308	11.976
LOCKHEED L-1011	47.346	54.178	16.866
CONCORDE	25.552	62.103	11.405

Note: All dimensions are in meters unless specified otherwise.

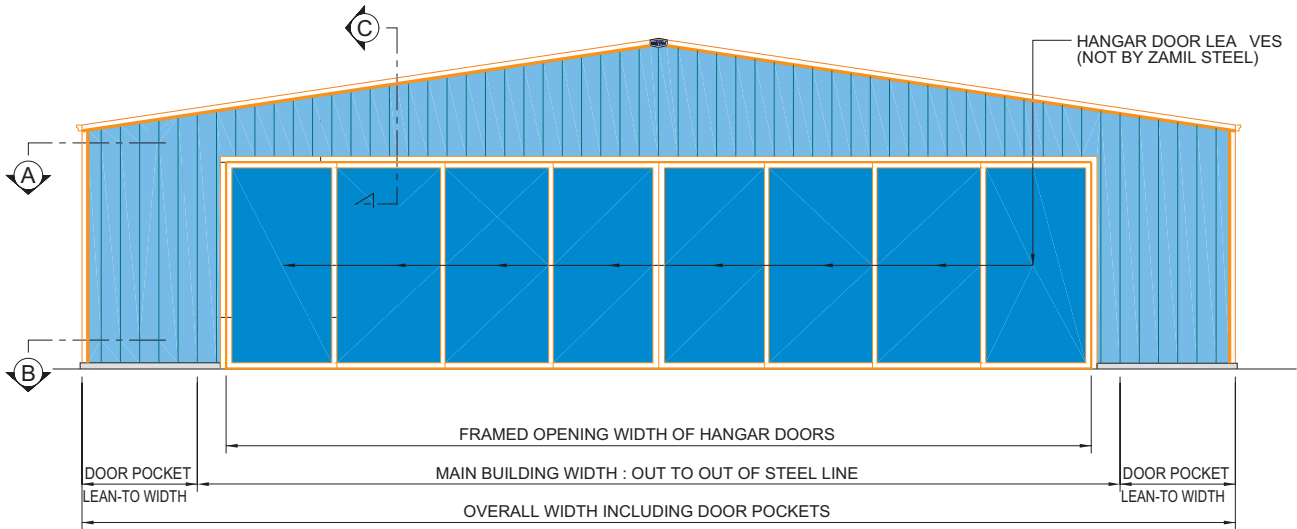

**ELEVATION** : FACADE OF AIRCRAFT HANGAR WITH HANGAR DOORS

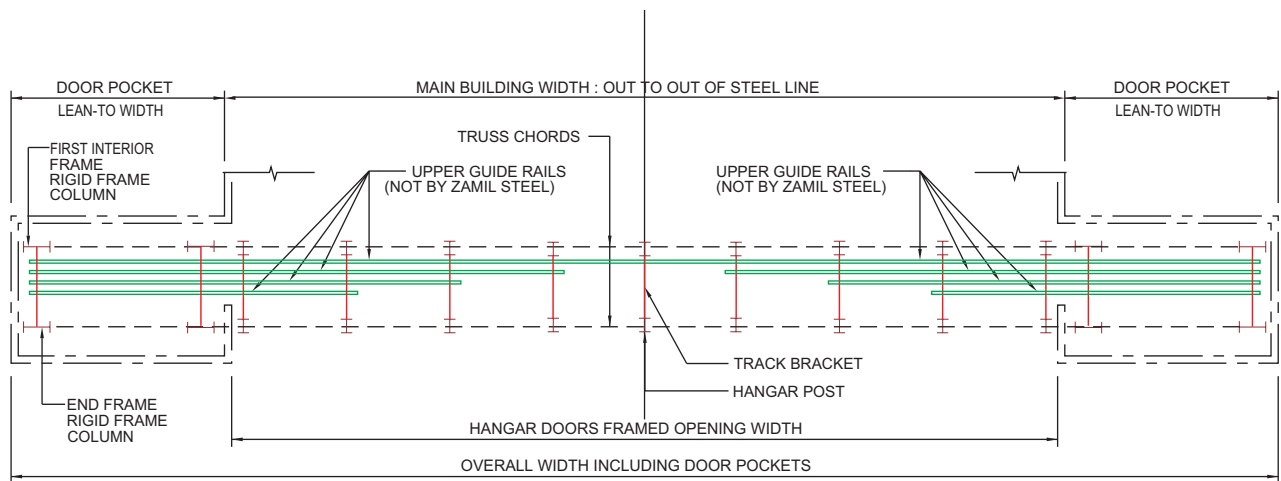

**SECTION-A** : UPPER GUIDE RAIL LAYOUT

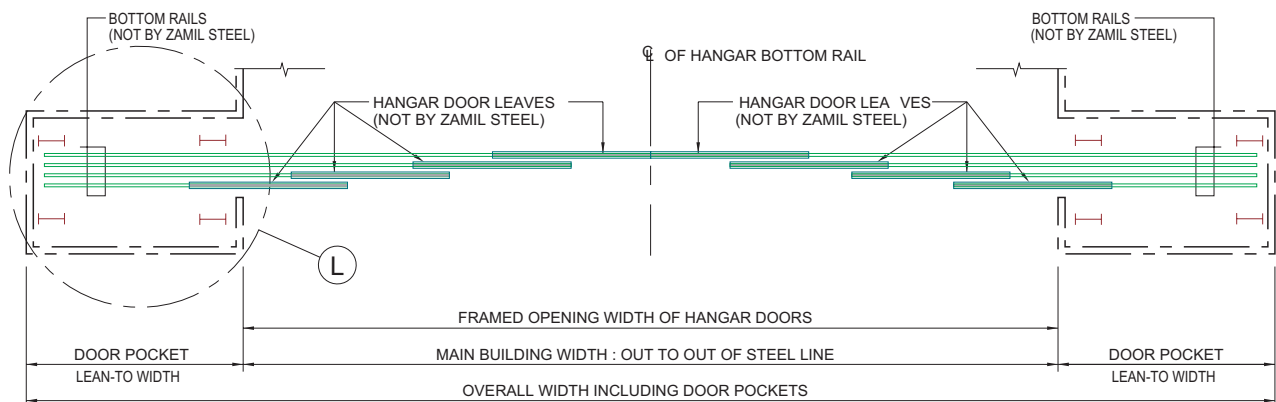

**SECTION-B** : LOWER GUIDE RAIL LAYOUT



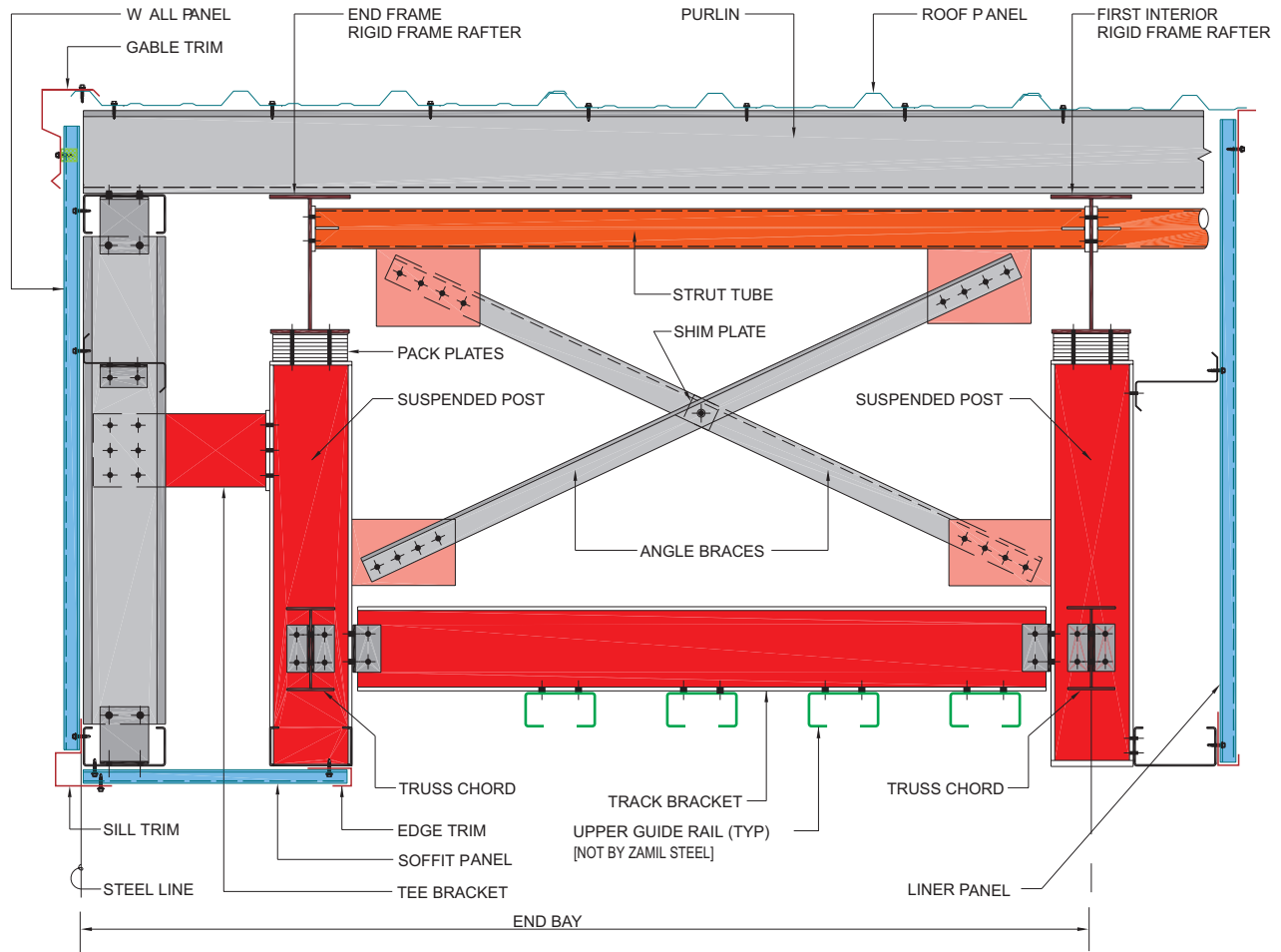

**SECTION-C** : HANGAR DOOR SUPPORT

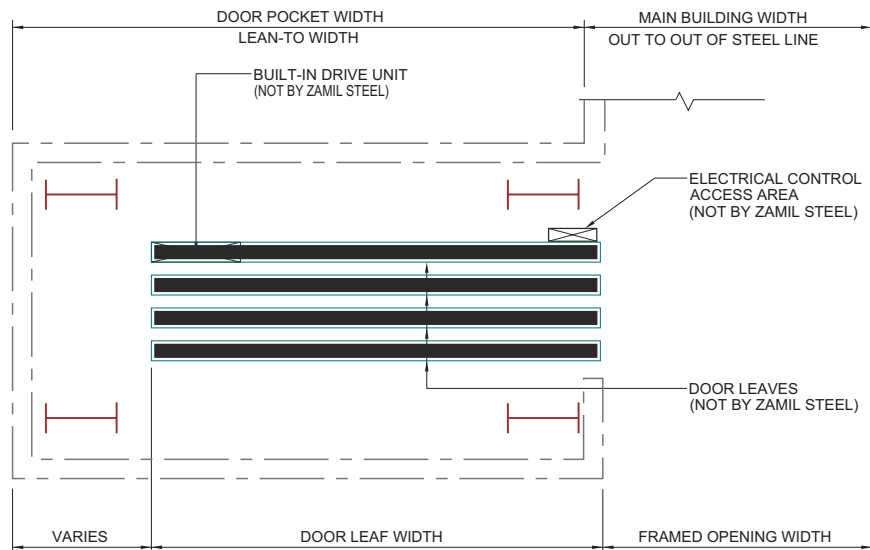

**DETAIL-L** : DOOR LEAVES STORED INSIDE OF POCKET



**STRUCTURAL  
CORROSION  
PROTECTION**

C  
H  
A  
P  
T  
E  
R

18

# Structural Corrosion Protection

18.1	General .....	437
18.2	Elements of Corrosion Protection .....	438
18.3	Surface Preparation .....	442
18.4	Paint Systems .....	447

The steel structures of pre-engineered buildings need to be protected from corrosive environmental factors such as moisture, salt, dust and chemicals. The degree of exposure of the steel structure to a particular environment often determines the most cost-effective corrosion protection system. The enduser of a pre-engineered building must be able to define what his building will be used for, what climatic and environmental conditions will prevail at the building site and how long does he expect to use his building. Based on this input Zamil Steel can then recommend a cost effective corrosion protection system based on the vast experience it has acquired during the past 20 years in most end-use applications of pre-engineered buildings from simple enclosed warehouses to chemical plants; and in all types of environments from dry inland areas to tropical coastlines.

The choice for a corrosion protection system needs not be the most expensive. What is required is the provision of adequate corrosion protection throughout the planned usage period of the building. There is no reason to protect the steel structure of a building with a coating system that will last 30 years when the building itself will become redundant in 20 years.

Over-specifying a corrosion protective system will result in unnecessary high cost implications. On the other hand, under estimating the required degree of corrosion protection can cause a problem especially when proper care of the steel while it is stored at the jobsite and during erection, is not taken. A poor choice of the corrosion protection system, improper site storage conditions, rough handling, and improper application of finish coats at the site (when required) is a sure way of shortening the service life of the steel structure.



A corrosion protection system is generally composed of three elements:

- Steel surface preparation
- Shop primer
- Paint system

Although Zamil Steel is in a position to recommend a complete corrosion protection system, we generally limit ourselves to the steel surface preparation and the application of a shop primer.

The Zamil Steel standard 25 microns Sigmazam red-oxide primer (conforming to SSPC-PS-7.00 1982 (or equivalent), applied over solvent cleaned steel, is intended to protect the steel against excessive rusting during transport (from factory to jobsite) and during the relatively short period of erecting the steel. The performance of this red oxide primer on its own and without the application of any further coatings has proven to be adequate in the majority of applications, particularly when the erected building is enclosed, ventilated and is not exposed to a corrosive environment. It is strongly recommended that the owner or specifier of a pre-engineered building evaluate the necessity for additional site painting and ensure that any paint, applied at the site, is compatible with this primer.

In a Zamil Steel pre-engineered building the structural components that require corrosion protection comprise of primary built-up plate members and hot rolled members such as columns, rafters, mezzanine beams, crane runway beams, etc. and secondary cold-formed members such as roof purlins, wall girts, etc. As part of its standard product line, Zamil Steel offers galvanized and Zinalume coated secondary members, which provide maximum service life, under almost all service conditions, at a very reasonable cost.

Zamil Steel is in a position to help customers to specify the most cost-effective corrosion protection

system for almost all building usage applications. To enable us to do that the customer must follow these steps:

- Determine the building's exterior and interior environmental conditions.  
Refer to Table 1 : Environment Categories According to BS 6150.
- Choose the degree of protection desired and determine the typical painting system applicable based on the internal and external environmental conditions of the building.  
Refer to Table 2 : Typical Paint Systems Used for Corrosion Protection.
- Choose a generic paint system (which matches the applicable paint system) that results in an acceptable cost, serviceability (i.e. over-coatability after a period of time) and other desired features.  
Refer to Table 3 : Main Generic Types of Paint and Their Properties.
- Make a generic specification based on the above steps.

Consequently Zamil Steel can then recommend a detailed specification of surface preparation, primer and additional paint coats (if required) in addition to recommending a paint manufacturer and the manufacturer's product number. If a specific paint manufacturer and product is desired by the customer, Zamil Steel will use that paint system as long as that product satisfies the quality and application requirements of Zamil Steel.

**Table 1 : Environment Categories According to BS 6150**

Severity of Exposure	Typical Exterior Conditions	Typical Interior Conditions
<b>Mild</b>	Inland areas (more than 10 km from the coast), non-industrial and with average rainfall.	Dry, well ventilated environments, e.g. most domestic, commercial and light industrial buildings. Possible occasional light condensation.  Little soiling, abrasion or handling of surfaces.
<b>Moderate</b>	Semi-coastal areas (3 km to 10 km inland), non-industrial, with average rainfall. Inland area (more than 10 km from the coast), urban or light industrial, with mild atmospheric pollution but not in close proximity to industrial plants or similar sources of significant pollution.	As for "mild" but with more frequent moderate condensation. Possible mild atmospheric pollution in light industrial environments.  Moderate soiling, abrasion or handling of surfaces.
<b>Severe</b>	Coastal areas subject to salt spray (e.g. up to 3 km inland), non-industrial, with average rainfall.  Inland industrial areas with significant atmospheric pollution.  Areas with a driving rain index of 7 or more, see BRE Digest No. 127(1).	Environments subject to frequent high humidity or heavy condensation, especially if pollutants, e.g. sulphur dioxide or ammonia, are present.  Environments in which heavy soiling or hygiene requirements necessitate frequent cleaning of surfaces.  Surfaces subject to heavy abrasion or impact.
<b>Very Severe</b>	Coastal/Industrial areas with significant atmospheric pollution.	Buildings in which processes or activities give rise to continuous high humidity or heavy condensation or are a source of aggressive fumes, dusts or waste products.  Surfaces in contact with chemicals, chemical solutions, and other aggressive agents.

Table 2 : Typical Paint Systems Used for Corrosion Protection

Environment	Indoor Environment		Outdoor Environment			
	Dry	Wet <sup>1</sup>	Rural <sup>2</sup>	Industrial	Coastal	Coastal Industrial <sup>3</sup>
Minimum (Usual)	A0 <sup>4</sup>	A1	A2 B1 B2	B3 C1 D1	C2 D1	C2
Better	–	A2 A3	B2 B3	C2 D2	C3 D2	D3
Best	–	A3 or B3	C1	C3 D3	D3	E

- A0 : No treatment  
A1 : Hand clean to St2 + primer  
A2 : Blast clean Sa 2<sup>1</sup>/<sub>2</sub> + corrosion preventive paint  
A3 : Blast clean Sa 2<sup>1</sup>/<sub>2</sub> + corrosion preventive paint + top coat

- B(B1 to B3) : Oil drying types (100 - 130 microns)  
C(C1 to C3) : One pack chlorinated rubber and vinyl types (130 - 280 microns)  
D(D1 to D3) : Epoxy system (150 - 300 microns)  
E : Polyurethane (300 - 400 microns)

<sup>1</sup> Wet means condensation for short periods. The longer the wet periods the better the coating must be.

<sup>2</sup> Also used for frequently wet indoor environments.

<sup>3</sup> Also used for outdoor heavy industrial environments.

<sup>4</sup> In some countries a better quality is normally required such as A1 or A2.



**Table 3 : Main Generic Types of Paint and Their Properties**

Paint Type	Cost	Tolerance of Poor Surface Preparation	Chemical Resistance	Solvent Resistance	Over-Coatability after aging	Other Comments
<b>Bituminous</b>	Low	Good	Moderate	Poor	Good with coatings of same type	Limited to black and dark colors. Thermo-plastic
<b>Oil-Based</b>	Low	Good	Poor	Poor	Good	Cannot be overcoated with paints based on stick solvent
<b>Alkyd Epoxy-Ester, etc.</b>	Low Medium	Moderate	Poor	Poor Moderate	Good	Good decorative properties
<b>Chlorinated Rubber</b>	Medium	Poor	Good	Poor	Good	High-build films remain soft and are susceptible to sticking
<b>Vinyl</b>	High	Poor	Good	Poor	Good	
<b>Epoxy</b>	Medium-High	Very Poor	Very Good	Good	Poor	Very susceptible to chalking in U.V.
<b>Urethane</b>	High	Very	Very	Good	Poor	Better decorative properties than epoxies
<b>Inorganic Silicate</b>	High	Very Poor	Moderate	Good	Moderate	May require special surface preparation

Surface preparation addresses the suitability of the steel substrate to accept a primer and additional paint coats. It involves two factors:

- A required degree of cleanliness (freedom from oil, grease, rust and other contaminants)
- A required surface profile for mechanical adhesion

No coating system will perform as intended if surface preparation is ignored or is inappropriate. On the other hand, over specifying the surface preparation will be costly and may not be of significant benefit to the desired result.

When a specification for surface preparation is not available Zamil Steel will use the recommended surface preparation given by the paint manufacturer as listed in its product data sheet.

The *cleanliness* of the steel substrate is important for proper wetting and adhesion during and after the application of the coating and for the successful long-term performance of the coating system. The presence of water, oil, grease and other contaminants prevents paint from adhering properly to the substrate. Excessive rust in the substrate results in eventual flaking and peeling of the paint. Loose mill scale results in immediate paint flaking whereas tightly adhering mill scale may allow the coating to last for several years.

Different exposure conditions and paints require different level of cleanliness. Table 4 gives the recommended surface preparation technique for various exposure conditions (this table should be used together with Table 2). The vast majority of applications will normally fall in the first and second categories of exposure conditions. Bear in mind that the exposure condition is for the *completed* building, which in the majority of cases is enclosed and well ventilated.



Table 5 is a summary of the different surface preparation specifications given by the Steel Structures Painting Council. Zamil Steel is able to perform all of these except SP4 and SP5, which are not part of our standard offering. The Zamil Steel standard of solvent cleaning (augmented when necessary by hand tool cleaning or brush-off blasting) for Zamil Steel's standard red-oxide primer is adequate for the majority of applications and has proven to be suitable even with other types of paint which do not require deep anchor profiles.

Our steel is generally clean and of a superior rust resistant grade due to our policy of storing the plate inventory of raw materials indoors and our shop flow which keeps materials in an enclosed building up to the time it is painted in a covered area.

The *surface profile* of the steel substrate is a measure of the roughness required for optimum adhesion of paint. It is important because it increases the surface area and provides a mechanical anchor. Paints with excellent wetting characteristics (and the majority of oil-based and alkyd primers) are tolerant of relatively smooth surfaces like those resulting from tightly adhering mill scale. High build epoxies and inorganic paints normally require deeper surface profiles achieved only by blasting the substrate. As a rule, thick coatings require a deeper profile than thin coatings to bond properly to the substrate.

The *profile anchor pattern* or *roughness* is the average depth (or height) from peak to valley caused by the impact of the abrasive onto the substrate. Figure 1 is an illustration, which shows “R” as the roughness. Excessive roughness should be avoided since corrosion can easily occur on peaks where the paint coating is thinner. Furthermore, the deeper the anchor profile, the more paint is required to achieve a desired **Dry Film Thickness (DFT)**.

Zamil Steel uses a combination of shot and grit blasting in an enclosed cabinet when a blasted surface is necessary. This allows us to achieve the level of cleanliness and roughness required for almost all types of paint applications. Many specifiers often ask for a specific type of abrasive blasting either sand, shot or grit. For cleaning purposes, there is no significant difference between the three except for the media and method of application.



**Table 4 : Surface Preparation Recommended for Various Service Conditions**

Exposure Condition	Surface Preparation	Minimum required for
<i>Atmosphere:</i> uncontaminated; interior	Solvent cleanser SSPC-SP 1	Oil-base, water-base, alkyds
<i>Atmosphere:</i> uncontaminated; exterior and interior	Power tool and hand tool SSPC-SP 3, 7	Oil-base, water-base, alkyds, bituminous
<i>Atmosphere:</i> uncontaminated; humid	Power tool or brush blast SSPC-SP 2, 3	Oil-base, alkyds, epoxy esters, bituminous, coal-tar epoxies
<i>Atmosphere:</i> industrial; humid; marine	Commercial blast SSPC-SP 6	Coal-tar epoxies, epoxy esters, phenolic varnishes, chlorinated rubbers
<i>Immersion:</i> water; brine; oils <i>Atmosphere:</i> chemical	Near-white blast SSPC-SP 10	Organic zinc-rich, vinyls, phenolic varnishes, epoxies, coal-tar epoxies, chlorinated rubbers
<i>Immersion:</i> chemicals; acids	White-metal blast SSPC-SP 5	Zinc silicates (inorganic zinc-rich), vinyls, phenolics, silicones, chlorinated rubbers

Comments on other surface preparation methods:

1. *Solvent and chemical:* Employed for special contamination, coatings, or service conditions. Quality of preparation varies widely.
2. *Flame cleaning:* May be substituted for brush blast cleaning, most paints are satisfied by this surface preparation quality.
3. *Pickling and phosphatizing:* May be substituted for white metal blast, near-white metal blast, or commercial blast, depending upon quality and service condition.

**Table 5 : Abstract of Surface Preparation Specifications\***

Specification & Subject	Purpose
SSPC-SP 1 Solvent cleaning	Removal of oil, grease, dirt, soil, salts, and contaminants by cleaning with solvent, vapor, alkali, emulsion or steam.
SSPC-SP 2 Hand tool cleaning	Removal of loose rust, loose mill scale, and loose paint to a specified degree, by hand chipping, scrapping, sanding and wire brushing.
SSPC-SP 3 Power tool cleaning	Removal of loose rust, loose mill scale, and loose paint to a specified degree, by power tool chipping, descaling, sanding, wire brushing and grinding.
SSPC-SP 4 Flame cleaning of new steel	Dehydrating and removal of rust, loose mill scale and some tight mill scale by use of flame and followed by wire brushing.
SSPC-SP 5 White metal blast cleaning	Removal of all visible rust, mill scale, paint and foreign matter by blast cleaning by wheel or nozzle (dry or wet) using sand, grit or shot. (For very corrosive atmospheres where high cost of cleaning is warranted.)
SSPC-SP 10 Near-white blast cleaning	Blast cleaning nearly to white metal cleanliness, until at least 95% of each element of surface area is free of all visible residues. (For high humidity, chemical atmospheres, marine or other corrosive environments.)
SSPC-SP 6 Commercial blast cleaning	Blast cleaning until at least two-thirds of each element of surface area is free of all visible residues. (For rather severe conditions of exposure.)
SSPC-SP 7 Brush-off blast cleaning	Blast cleaning of all except tightly adhering residues of mill scale, rust and coatings, exposing numerous evenly distributed flecks of underlying metal.
SSPC-SP 8 Pickling	Complete removal of rust and mill scale by acid pickling, duplex pickling or electrolytic pickling. May passify surface.
SSPC-SP 9 Weathering followed by blast cleaning	Weathering to remove all or part of mill scale followed by blast cleaning to one of the above standards as required.

\* Steel Structures Painting Manual, Volume 2, 1969 Printing, Steel Structures Painting Council, Pittsburgh, Pa. 15213.

Figure 1 : Surface Profile

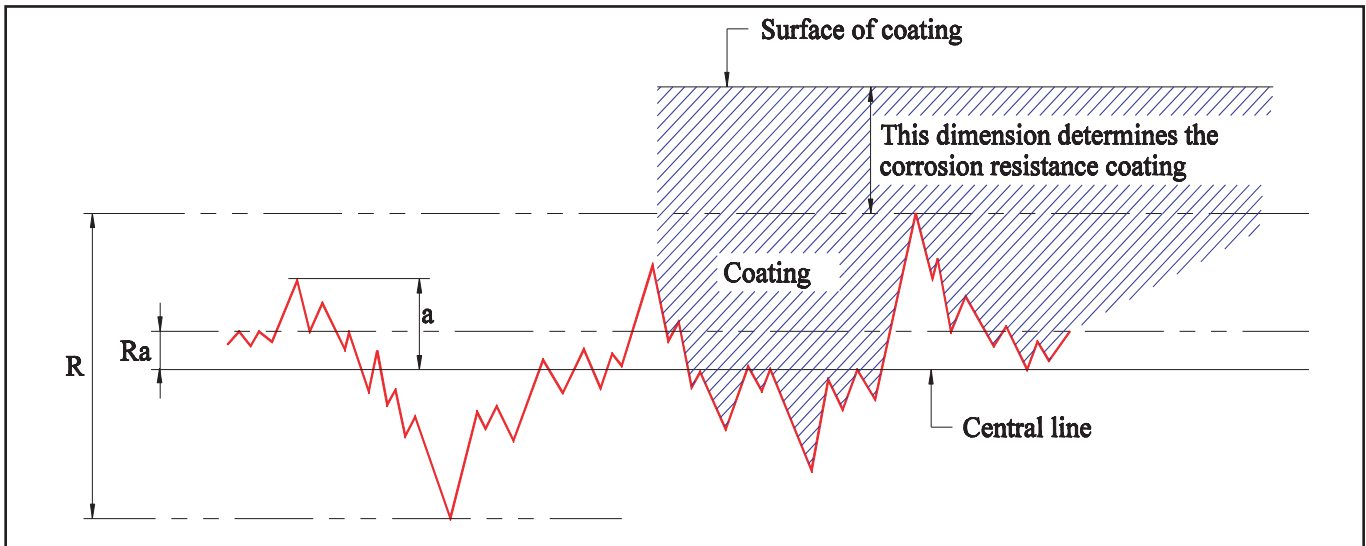

R = Distance between maximum peak to deepest valley (roughness).

Ra = Average distance of central line =  $\frac{\sum (a)}{n}$  where,

a = Height of individual peak from central line

N = Number of peaks measured

The average roughness is usually 1/6 of R.

Paints are composed primarily of pigments dispersed in a film form, or binder, which is either dissolved in solvent or emulsified in water to make the paint fluid enough to apply by brush, roller or spray. The basic composition of paint dictates its suitability to a particular combination of application conditions and protection requirements. Paints are normally used in combination with other paints to create a paint system.

A paint system generally consists of a primer, an intermediate coat and a finish coat applied in different thicknesses to achieve the total desired film thickness. For most painting systems, increasing the film thickness decreases permeability and improves performance and durability. Zamil Steel generally applies only a shop primer to the steel structures of its buildings in order to provide adequate protection during transport, storage at site for a limited period, and erection. Finish coats and intermediate coats are preferably applied at the job site just before the steel is erected in order to minimize handling damage.

Shop applied primers reduce the risk of corrosion of steel by preventing direct contact between moisture and air and the surface of the steel. Zinc-rich primers prevent the rusting of steel even if water gets through missed spots, breaks or pinholes in the coating. With the exception of zinc-rich paints, primers are not formulated to be exposed to the environment and require a finish coat for protection. However, if there is a risk of exposure to very acidic or alkaline chemicals, even zinc-rich primers, with all their durability attributes, must be finish-coated.

Zamil Steel has the capability to apply many types of primers from different paint manufacturers. Over the years, certain paints have proven to be reliable under different combinations of building applications and environmental exposures. Specifying these systems assures the owner of having proven paint products from reputed paint manufacturers with expert primer application.

When intermediate and finish coats are specified for a certain project, Zamil Steel consults with the paint manufacturer on compatibility and ease of application of the coat before a recommendation is made.

The following recommended paint systems, for the primary and secondary steel, are a result of Zamil Steel's extensive experience in this field. The actual paint system may be changed depending on the buyer's definition of the specific application. Zamil Steel Area Offices will guide the buyer in specifying the exact painting system required. When a customer specifies a different painting system or paint manufacturer, Zamil Steel reserves the right to review the specifications against the quality and application requirements of Zamil Steel.



### Primary Steel

Category	Building Environment	Primary Steel			
		Surface Preparation	Primer Coat	Intermediate Coat	Top Coat
1	Enclosed buildings with mild, well ventilated interior conditions	SP1/SP2 solvent and hand tool cleaning	Sigma 606P red oxide alkyd primer	Alkyd, acrylic or chlorinated rubber based paints (Recommended)	Alkyd, acrylic or chlorinated rubber based paints (Recommended)
2	Mild atmospheric exposure, interior and exterior	P1/SP2 solvent and hand tool cleaning	Sigma 606P red oxide alkyd primer	Alkyd, acrylic or chlorinated rubber based paints (Required)	Alkyd, acrylic or chlorinated rubber based paints (Required)
		SP7 brush-off blast cleaning	Sigma 7413 general purpose epoxy primer	Alkyd, acrylic or chlorinated rubber based paints (Recommended)	Alkyd, acrylic or chlorinated rubber based paints (Required)
3	Mild to moderately corrosive coastal and industrial atmospheres	SP10-Sa2-1/2 near-white metal blasting	Sigma 7402 zinc epoxy	For compatible systems see paint specs. (Recommended)	(Required)
			Hempel 1205-9A zinc chromate		(Recommended)
4	Polluted or coastal atmospheres	SP10-Sa2 _ near-white metal blasting	Sigma 7412 2-pack epoxy	For compatible systems see paint specs. (Recommended)	For compatible systems see paint specs.
			Sigma 7558 inorganic zinc		(Required)

### Secondary Steel

For all categories we recommend pre-galvanized coated steel. However, for categories 3 and 4, an expensive but viable option is to use the same paint system as the one recommended for the primary steel.



# **STRUCTURAL FIRE PROTECTION**

**C  
H  
A  
P  
T  
E  
R**

**19**

# Structural Fire Protection

19.1	General .....	451
19.2	Passive Fire Protection Systems .....	452
19.3	Fixed Fire Protection Systems .....	455
19.4	Fire Detection and Alarm Systems .....	456

Modern building codes specify minimum fire resistance requirements based on studies by fire protection engineers. The fire resistance rating is expressed as the number of hours a structural assembly is able to withstand when exposed to a standard time temperature test, ASTM E119, before the first critical point in its behavior is reached.

Steel begins to lose its stiffness at temperatures in the neighborhood of 538°C (1000°F). ASTM E119 standard fire test requires that average temperature readings do not exceed 538°C (1000°F) for columns, and 593°C (1100°F) for beams. Individual readings must not exceed 538°C (1000°F) for columns and 649°C (1200°F) for beams.

A fire exposure of a severity and duration sufficient to raise the temperature of steel above the fire criteria temperature will seriously impair the steel's ability to sustain loads above unit stresses or plasticity load factors permitted by the AISC specifications.

Under such an exposure, the members upon which the stability of the structure depends, should be protected by fire resistant materials or systems. These must be capable of holding the average temperature of the steel below the limits specified for the fire test standard: Fire Protection Methods and Materials.

A wide range of products and systems are available to detect and protect structural steelwork from fire. They are divided into three major categories;

- Passive Fire Protection
- Fixed Fire Protection
- Fire Detection and Alarm

To select the appropriate system(s) for fire protection and detection, the following factors should be considered;

- Appearance
- Mechanical Durability
- Compatibility with the Environment
- Compatibility with any Corrosion Protection System
- Space Requirements
- Construction Program
- Application or Fixing Rate
- Cost

This section is intended to educate the reader about the available fire protection systems. For further details, you need to contact fire protection specialists directly.

In recent years passive fire protection systems have been extended to incorporate the fire protection of structural steel beams, columns, floor slabs and other building components such as firewalls, wall linings, partition walls and ducting systems.

All passive products comply with BS 476 part 22 or equivalent. The fire resistance varies from half-an-hour up to four hours depending upon the type of product and its application. The main passive fire protection systems are: *boarded systems*, *intumescent products*, *spray applied systems* and *concrete encasements*.

### Boarded Systems

These are pre-formed boards usually made from gypsum, mineral fibers or naturally occurring plate-like materials such as vermiculite and mica using cement and/or silicate binders.

The thickness of such boards range from 6 to 80 mm depending on the material they are made of. Their fire resistance ranges from one hour to four hours.

Boards may be fixed to steelwork using mechanical methods, (screws, straps and/or galvanized angles) or they may be glued and pinned. A box configuration is generally used, except for very deep sections (above 800 mm) where it is advisable to have the board fire protection follow the section profile.

Boarded systems are particularly suitable for the protection of columns where smooth surfaces are required to achieve a neat appearance. They provide the most suitable finish for accommodating other trades.

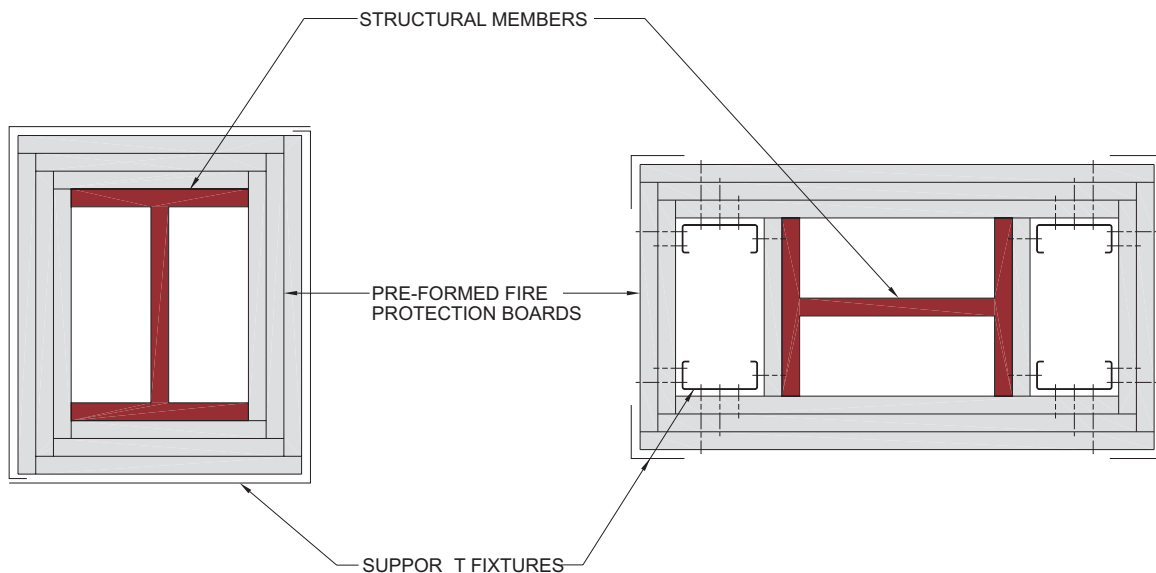

(PLAN) : BOARDED SYSTEMS

**Intumescent Products**

Intumescent products are designed to seal bulkheads, small gaps or airline cracks where mechanical and electrical utilities pass from one area of a building to another. The products range from intumescent coating, applied to a substrate as a thin film, to mastic and pipe collars.

At ambient temperature the ingredients are perfectly stable and non-reactive. When the temperature increases (usually above 200°C) the intumescent ingredients undergo a chemical reaction and produce an expanded char layer sometimes fifty times thicker than the original film thickness. This char has low thermal conductivity and good insulating characteristics which produce good thermal protection to the substrate.

**Spray Applied Systems**

These are lightweight fire protection materials that are divided into two main classes:

- Based on vermiculite or perlite plus a binder, often cement.
- Based on mineral fibers such as rockwool.

This form of protection is generally applied directly to the steel surface and follows its profile. In some situations it is applied to an expanded steel lathing to form a hollow box protection. Many of the



products designed for internal usage can be applied directly to unpainted steel.

However, only few materials are suitable for use in externally exposed situations where it is necessary to provide the steel with an adequate corrosion protection. Depending on their thickness, such products can achieve up to four hours of fire resistance. Some require mesh reinforcement to achieve longer periods of fire resistance.

Spray applied systems provide the cheapest and fastest method of protection and are particularly suitable for protection of beams which are generally concealed by suspended ceilings.

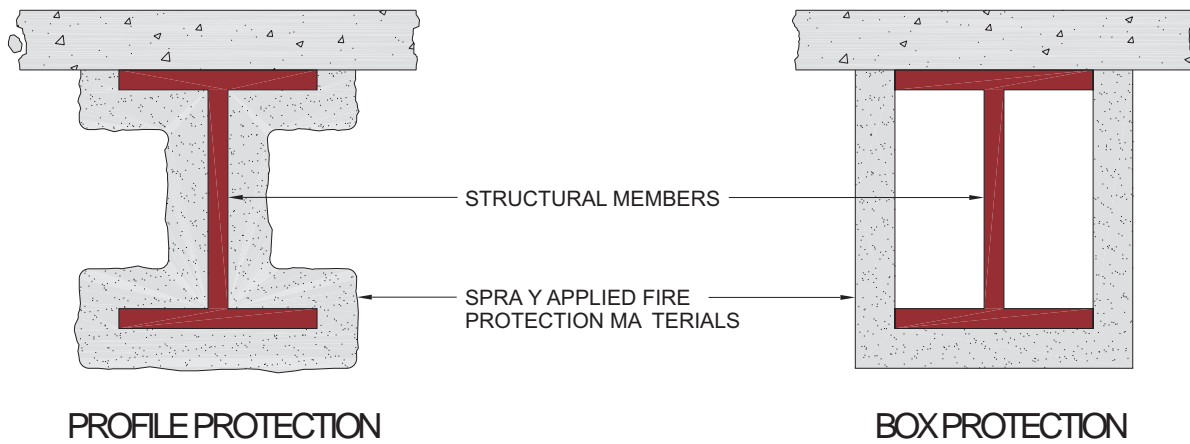

**(PLAN) : SPRAY APPLIED SYSTEMS**

### Concrete Encasements

One of the advantages of concrete is that it is a fire resistant material. When subjected to high temperatures it slowly releases its retained water. The temperature on the concrete face opposite to the fire does not exceed 100°C until all the water in the concrete has been released.

The selection of aggregate is critical to the fire-resistance of concrete. Aggregate containing 60% or more of quartz, chert or granite is not as fire resistant as those containing limestone. Therefore,

concrete with such aggregate must be increased in thickness to obtain a comparable fire resistance. The use of lightweight aggregates instead of stone greatly improves the concrete's fire resistance.

Concrete with at least 60% limestone, shale or trap rock aggregates can provide up to 4 hours of fire-resistance with only 50 mm thick encasement thickness.

Due to its heavy weight concrete is mainly used to fire protect columns although it is widely used to protect steel floors and roof decks.

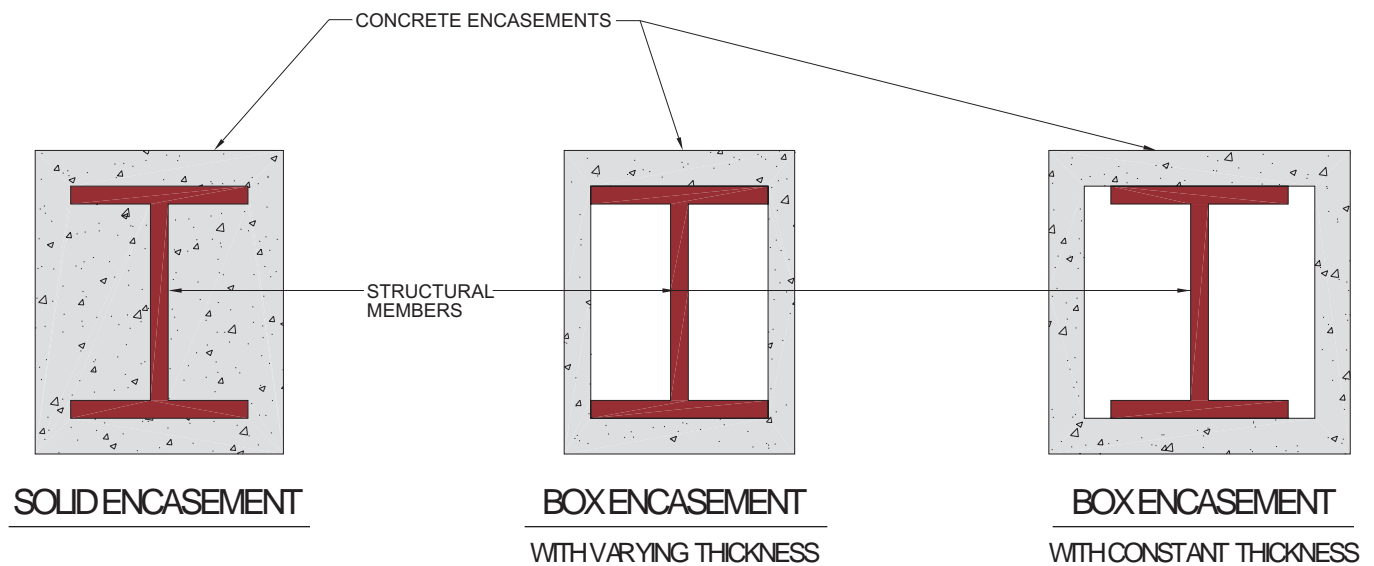

PLAN : CONCRETE ENCASEMENT

Fixed fire protection systems installed in buildings or structures are activated once any signs of fire appear. Their main purpose is to extinguish fire at its early stages. There are several fixed fire protection systems of which the three most popular are: *sprinkler systems*, *gaseous extinguishing systems* and *foam systems*.

### Sprinkler Systems

Sprinklers have long been acknowledged as the first line of attack in a fire situation. Some records show that, in fully sprinklered premises, 99% of all fires have been controlled by sprinkler systems.

The reason sprinklers are so effective is because they attack the seat of the fire before it has time to spread. There is no excessive use of water to extinguish the fire; 65% of fires in sprinklered locations have been controlled by five or fewer heads.

### Gaseous Extinguishing System

There will always be risk areas where there is a need to extinguish a fire at the earliest possible stage, to minimize damage to extremely valuable or sensitive equipment, and without risk to personnel. In such instances the use of a gaseous extinguishing system is a good choice.

One type of gaseous extinguishing systems is CO<sub>2</sub> systems. Although carbon dioxide fire protection is not new, its unique fire protection benefits have enabled it not only to survive, but evolve over the years. Today's CO<sub>2</sub> systems utilize sophisticated detectors, hi-tech control panels and computer aided design of agent pipe network.

Gaseous systems are normally used in *computer rooms*, *control rooms* and *switch-gear rooms*, etc.

### Foam Systems

Low, medium or high expansion foam is now available for any industry that involves the use of highly flammable liquids that could be subject to a variety of intense fires.

When mixed with proper amounts of fresh or salt water and air in foam hardware, the system produces foam bubbles that are light enough to float on the surface of hydrocarbon fuels.

Fire fighting foam extinguishes and secures fuels in three stages. It creates a foam blanket, which deprives the fire of oxygen, it significantly reduces vaporization by up to 95% and the water content helps cool the fuel.

The latest foam systems have a long storage life. They normally are non-corrosive to most common construction materials and have minimal effect on the environment. Foam systems have a proven track record in protecting hazards in buildings such as *process areas* and *aircraft hangers*.

The installation of fire detection and alarm systems is essential especially in buildings that contain a large number of people at one time such as offices, hospitals, shopping centers, factories, etc., to help in immediate and speedy evacuation of the building.

Generally, a fire detection and control system is temperature sensitive. It will respond to moderate temperature changes in the building. Such systems are normally designed so as not to respond to gradual increase in temperature, seasonal changes in ambient temperature, arc lights, welding torches, infrared light or ultraviolet rays.

Furthermore, different alarm and communication systems are available and can be used depending on the type and function of the building. Such systems include *voice alarm systems* that provide manually or automatically, relayed instructions to aid evacuation; *public address systems* that provide general paging and announced facilities including music and speech reinforcement; and *integrated systems* used to complement and operate with fire detection systems.



# FOUNDATIONS

# C H A P T E R

20

# Foundations

20.1	General .....	459
20.2	Typical Footing Details .....	460
20.3	Footing Design .....	461
20.4	Slab Design .....	463

This chapter is intended to serve as a guide for determining the size and the steel reinforcement of footings supporting the primary columns of pre-engineered steel buildings.

The design of a foundation requires two major inputs:

1. The bearing capacity ( $\text{kg}/\text{cm}^2$ ) of the soil, which is the ability of the soil to resist applied loads.
2. The columns reactions (kN) of the steel building, which are the loads transferred from the structure to the base of the columns.

Zamil Steel's input is restricted only to the provision of column reactions. These column reactions are provided in the anchor bolt plan furnished with both approval drawings and erection drawings. The reactions provided in the approval drawings can be used as a starting point for the design of foundations. But the construction of foundations must not start before the final anchor bolt plan is received and verified against the data used in the design of foundations. The soil bearing capacity must be obtained through a specialist in soil investigation.

**The suggested foundation details in this chapter are intended for reference only. Final foundation design requires a qualified foundation engineer.**

A typical foundation structure consists of spread footings and a slab on grade. The footings must be designed for vertical and horizontal loads caused by gravity loads (dead, live, collateral, etc.), wind (pressure or uplift), earthquake loads, etc.

When a ground slab is used, it is possible to make use of it structurally by transmitting the horizontal loads into the slab and dissipating them into the subsurface soil by means of frictional forces between the ground slab and the soil beneath it. This technique requires the provision of horizontal

V-shaped reinforcing bars (called hairpins) anchored around the anchor bolts and protruding into the slab. See the following pages for more details. The provision of hairpins results in more economy in the design of foundations.

The details and design tables in this chapter pertain to spread footings for pin connected columns only (i.e. columns with no moment reactions). The soil capacities used are typical for sand and clay type of land. No soil stability problems are assumed in the soil.



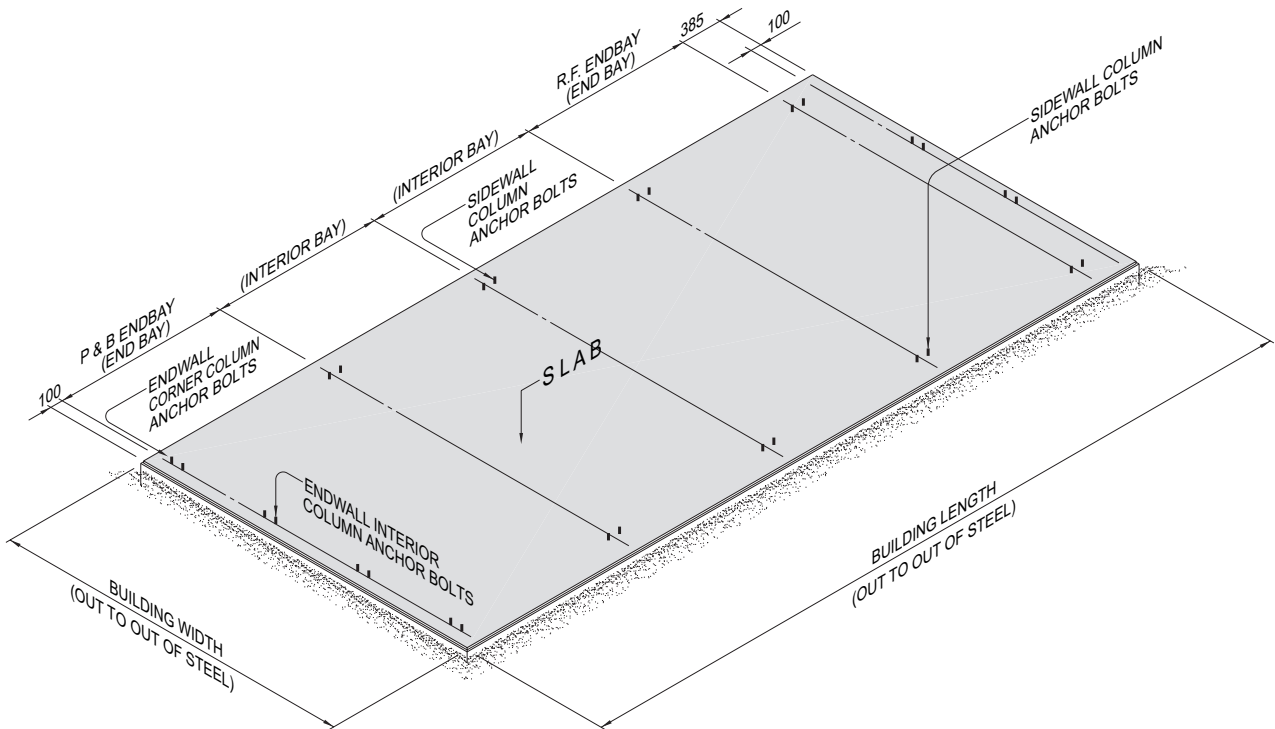

### ANCHOR BOLTS LAYOUT

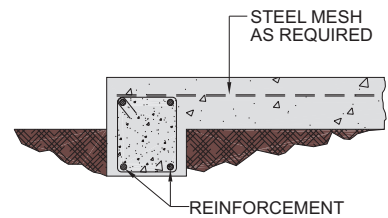
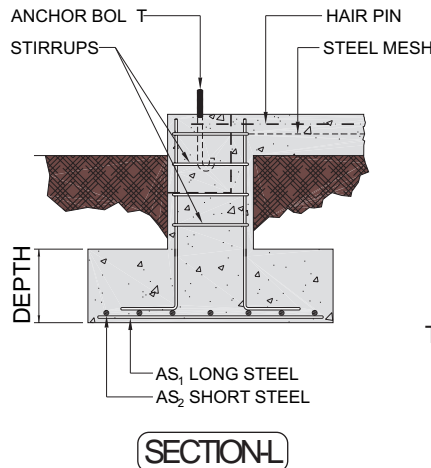
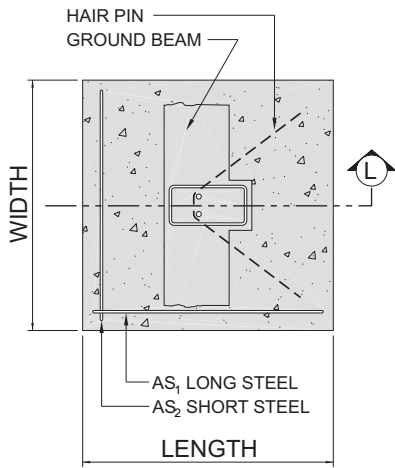

### PERIMETER FOOTING

TYPICALLY PROVIDED FOR ENDWALL COLUMN

### SPREAD FOOTING

NOTE: FOOTING SIZES, REINFORCING BAR DESIGN AND THE USE OF HAIR PINS SHOULD BE OBTAINED FROM THE DESIGN TABLES IN SECTION 20.3, PAGE 1 AND 2 OF THIS CHAPTER.

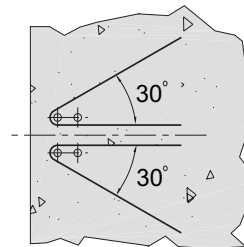

MULTIPLE HAIR PINS

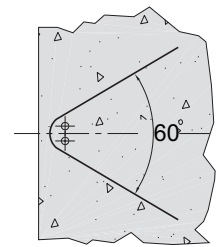

SINGLE HAIR PIN

### HAIR PIN ARRANGEMENT

### Spread footing design with hair pins

The following tables present guidelines for sizing spread footings and their steel reinforcements.

Soil Bearing Capacity = 0.75 kg/cm <sup>2</sup>						
Vertical Reaction (kN)	Uplift Capacity (kN)	Footing Size			Footing Reinforcement	
		Length (cm)	Width (cm)	Depth (cm)	Steel Grade 60	
					AS <sub>1</sub>	AS <sub>2</sub>
40	4	80	80	35	4 Nos. 14 mm ø	4 Nos. 14 mm ø
60	6	100	100	35	5 Nos. 14 mm ø	5 Nos. 14 mm ø
70	11	140	120	35	5 Nos. 14 mm ø	6 Nos. 14 mm ø
110	14	160	140	35	6 Nos. 14 mm ø	7 Nos. 14 mm ø
140	24	180	160	35	7 Nos. 14 mm ø	8 Nos. 14 mm ø
175	33	200	180	35	7 Nos. 14 mm ø	9 Nos. 14 mm ø
250	36	220	200	35	9 Nos. 14 mm ø	10 Nos. 14 mm ø
375	50	260	240	35	11 Nos. 14 mm ø	13 Nos. 14 mm ø

Soil Bearing Capacity = 1.5 kg/cm <sup>2</sup>						
Vertical Reaction (kN)	Uplift Capacity (kN)	Footing Size			Footing Reinforcement	
		Length (cm)	Width (cm)	Depth (cm)	Steel Grade 60	
					AS <sub>1</sub>	AS <sub>2</sub>
90	4	80	80	35	4 Nos. 14 mm ø	4 Nos. 14 mm ø
140	6	100	100	35	5 Nos. 14 mm ø	5 Nos. 14 mm ø
190	11	140	120	35	5 Nos. 14 mm ø	6 Nos. 14 mm ø
280	14	160	140	35	6 Nos. 14 mm ø	7 Nos. 14 mm ø
360	24	180	160	35	7 Nos. 14 mm ø	8 Nos. 14 mm ø
440	33	200	180	35	7 Nos. 14 mm ø	9 Nos. 14 mm ø
500	36	220	200	35	9 Nos. 14 mm ø	10 Nos. 14 mm ø
750	50	260	240	35	13 Nos. 14 mm ø	14 Nos. 14 mm ø

The quantity and size of hair pins required to resist horizontal reactions is noted below:

Horizontal Reaction (kN)	Hair Pin Quantity / Size
10	1 Nos. 10 mm ø
20	1 Nos. 13 mm ø
30	1 Nos. 13 mm ø
40	1 Nos. 16 mm ø
50	1 Nos. 19 mm ø
75	1 Nos. 22 mm ø
100	2 Nos. 19 mm ø
150	2 Nos. 22 mm ø
200	3 Nos. 19 mm ø
250	3 Nos. 22 mm ø

The design recommendations in these tables are based on the following assumptions:

- Horizontal reactions are transferred to the ground slab and subsequently dissipated into the subsurface soil through the use of HAIR PINS.
- Concrete compressive strength = 3,000 psi (210 kg/cm<sup>2</sup>).
- Minimum concrete protection for reinforcement 75 mm.
- AS<sub>1</sub> is the steel bars in the long direction (length). AS<sub>2</sub> is the steel bars in the short direction (width).
- Uplift capacity is based only on the concrete weight of footing. It may be increased if soil overburden is provided.
- Minimum length of hair pin must not be less than 4 m (2 m on each side of anchor bolts). The foundation engineer must calculate the required length of hair pin by determining the development length of slab reinforcement necessary to transfer the horizontal force from the hair pin to the slab.

### Spread footing design without hair pins

When a ground slab is not used as part of the foundation sub-structure, hair pins cannot be used and footings have to be designed to resist both vertical and horizontal loads.

For this condition the following table provides guidelines for determining footing size and steel reinforcement.

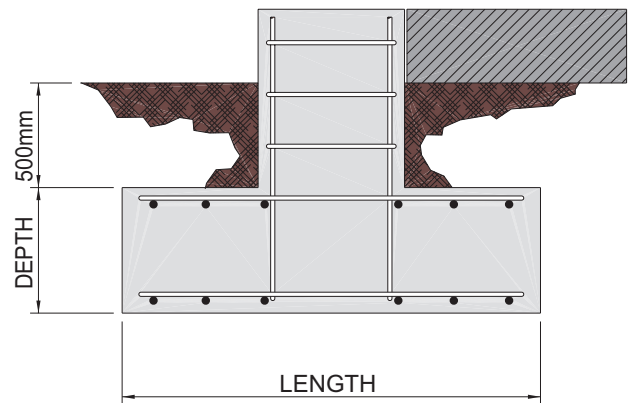
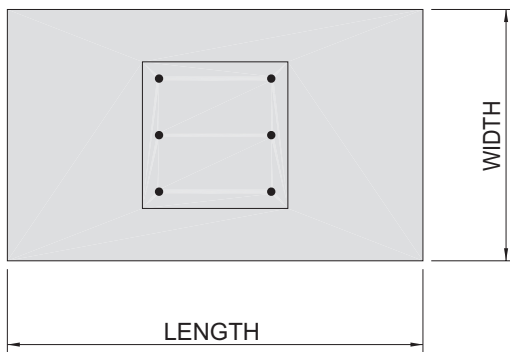

Column Reactions		Footing Size			Footing Reinforcement			
Vertical	Horizontal	Length	Width	Depth	Bottom Steel		Top Steel	
kN	kN	(cm)	(cm)	(cm)	Longitudinal	Transversal	Longitudinal	Transversal
30	15	150	150	35	6 Nos. 16 mm $\phi$	6 Nos. 16 mm $\phi$	6 Nos. 12 mm $\phi$	6 Nos. 12 mm $\phi$
45	20	180	180	35	6 Nos. 16 mm $\phi$	6 Nos. 16 mm $\phi$	6 Nos. 12 mm $\phi$	6 Nos. 12 mm $\phi$
60	60	260	180	50	7 Nos. 20 mm $\phi$	9 Nos. 20 mm $\phi$	7 Nos. 12 mm $\phi$	9 Nos. 12 mm $\phi$
75	80	300	210	50	8 Nos. 20 mm $\phi$	10 Nos. 20 mm $\phi$	8 Nos. 12 mm $\phi$	10 Nos. 12 mm $\phi$
90	100	320	210	50	8 Nos. 20 mm $\phi$	11 Nos. 20 mm $\phi$	8 Nos. 12 mm $\phi$	11 Nos. 12 mm $\phi$
105	160	360	280	50	10 Nos. 20 mm $\phi$	13 Nos. 20 mm $\phi$	13 Nos. 12 mm $\phi$	13 Nos. 12 mm $\phi$

The above table is based on the following assumptions:

1. Reinforcing bars are made of Grade 60 / deformed (60,000 psi tensile strength or 42 kg/mm<sup>2</sup>) steel.
2. Concrete compressive strength is 210 kg/cm<sup>2</sup>
3. Soil bearing capacity = 1.0 kg/cm<sup>2</sup>



The design of a concrete slab on ground must be carried by a qualified foundation engineer. The following table is provided only for guidance. The

capacity of the slab depends on the thickness and quality of concrete, the reinforcement and the type of composition of the soil.

Type of Occupancy	Load (kN/m <sup>2</sup> )	Minimum Slab Thickness (mm)	Reinforcement	
			No. of Layers	Size
Sub-Slab under other slabs	-	50	None	
Residential or Light Commercial	< 5	100	One	150x150-4/4 WWF
Commercial, Institutional, Barns	10	125	One	150x150-5/5 WWF
Light Industrial, Gas Stations, Garages	20	150	One	150x150-6/6 WWF
Industrial and Heavy Pavement for Industrial Plants, Gas Stations, Garages	35	150	Two	150x150-6/6 WWF
Heavy Industrial	70	175	Two	12mm $\phi$ bars at 300mm c/c each way
Extra Heavy Industrial	120	200	Two	16mm $\phi$ bars at 300mm c/c each way

Notes:

1. **WWF** denotes "Welded Wire Fabric"
2. The above table is based on 210 kg/cm<sup>2</sup> compressive strength concrete.
3. For loads in excess of 20 kN/m<sup>2</sup>, investigate subsoil conditions with extra care. Proper compaction should be made to achieve the loading capacities provided in the table.
4. When one layer of reinforcement is required place it 50 mm below the top of the slab. When two layers of reinforcement are required place the second layer 50 mm above the bottom of the slab.

*At Zamil Steel we aim not only to obtain your current business but to make you a lifetime partner of ours.*

*We make sure that your business interests are perceived by our people, at all levels, to be as important to us as they are to you.*

*Our goal is to earn your trust, your confidence and all your future business.*

*If we were to describe Zamil Steel in just one sentence it would be:*

*"Zamil Steel is a pleasure to do business with". We invite you to work with us.*







# Chapters

1. INTRODUCTION
2. NOMENCLATURE
3. ENGINEERING PRACTICES
4. STANDARD STRUCTURAL SYSTEMS
5. OTHER STRUCTURAL SYSTEMS
6. SECONDARY STRUCTURAL FRAMING
7. BASIC STRUCTURAL SUBSYSTEMS
8. SINGLE SKIN PANELS
9. INSULATED SANDWICH PANELS
10. PANEL RELATED ACCESSORIES
11. OTHER STRUCTURAL SUBSYSTEMS
12. FLOOR SYSTEMS
13. BUILDING ACCESSORIES
14. INSULATION
15. SUNDRY PARTS
16. SPECIAL BUYOUTS
17. SPECIALTY BUILDINGS
18. STRUCTURAL CORROSION PROTECTION
19. STRUCTURAL FIRE PROTECTION
20. FOUNDATIONS

# TABLE OF CONTENTS

<b>1. Introduction</b>		<b>6. Secondary Structural Framing</b>	
1.1 Aims of this Manual	3	6.1 General	101
1.2 The Role of the Architect/Consultant	4	6.2 Cold-Formed “Z” Sections	102
1.3 The Pre-Engineered Building Concept	6	6.3 Cold-Formed “C” Sections	104
1.4 The Merits of Pre-Engineered Buildings	7	6.4 Cold-Formed Eave Strut Section	107
1.5 Applications of Pre-Engineered Buildings	11	6.5 Secondary Framing Details	108
1.6 The Zamil Steel Organization	16		
1.7 The Zamil Steel Advantage	19	<b>7. Basic Structural Subsystems</b>	
1.8 Zamil Steel Literature	22	7.1 General	115
1.9 Initiating a Request for Quotation	24	7.2 Bracing	116
1.10 Placing and Tracking an Order	25	7.3 Endwalls	119
		7.4 Jack Beams	134
<b>2. Nomenclature</b>		7.5 Expansion Joints	139
2.1 Basic Terms	31	7.6 Masonry Conditions	144
2.2 Abbreviations	50	7.7 Pre-cast Panels	146
<b>3. Engineering Practices</b>		<b>8. Single Skin Panels</b>	
3.1 General	55	8.1 General	151
3.2 Design Codes and Building Codes	56	8.2 Steel Panels	152
3.3 Design Loads	57	8.3 Steel Panel Paint Systems	154
3.4 Collateral Loads	59	8.4 Steel Panel Coating Tests	165
3.5 Mezzanine Live Loads	60	8.5 Steel Panels Properties & Load Tables	168
3.6 Building Material Weights	61	8.6 Aluminum Panels	176
3.7 Conversion Factors	62	8.7 Aluminum Panels Properties & Load Tables	177
3.8 Deflection Criteria	64	8.8 Exterior Roof and Wall Panel Details	182
3.9 Engineering Output	65	8.9 Interior Roof and Wall Liner Details	186
3.10 Building Design Certification	67		
<b>4. Standard Structural Systems</b>		<b>9. Insulated Sandwich Panels</b>	
4.1 General	71	9.1 General	203
4.2 Clear Span Buildings	72	9.2 Field Assembled Sandwich Panels (FASP)	204
4.3 Multi-Span Buildings	74	9.3 Factory Injected Sandwich Panels (Tempcon)	208
4.4 Space Saver Buildings	77		
4.5 Lean-To Buildings	78		
<b>5. Other Structural Systems</b>		<b>10. Panel Related Accessories</b>	
5.1 General	81	10.1 General	223
5.2 Single Slope Buildings	82	10.2 Curved Eaves	224
5.3 Multi-Gable Buildings	84	10.3 Flashing and Trims	226
5.4 Roof System Buildings	87	10.4 Gutters and Downspouts	229
5.5 Flat Roof Buildings	90		
5.6 Low Rise Buildings	93		

# TABLE OF CONTENTS

## 11. Other Structural Subsystems

11.1	General	241
11.2	Roof Extensions	242
11.3	Canopies	251
11.4	Fascias	255
11.5	Partitions	262
11.6	Cranes	267
11.7	Roof Monitors	274

## 12. Floor Systems

12.1	General	279
12.2	Mezannines	280
12.3	Open Web Steel Joists	286
12.4	Roof Platforms	295
12.5	Catwalks & Walkways	297
12.6	Staircases	304
12.7	Handrails	312
12.8	Ladders	315
12.9	Grating	318
12.10	Checkered Plates	319

## 13. Building Accessories

13.1	General	323
13.2	Personnel Walk Doors	324
13.3	Windows	328
13.4	Sliding Doors	330
13.5	Roll-Up Doors	336
13.6	Framed Openings	341
13.7	Ventilators	
13.7.1	General	345
13.7.2	Gravity Ventilators	349
13.7.3	Power Ventilators	355
13.8	Louvers	
13.8.1	General	358
13.8.2	Fixed Louvers	360
13.8.3	Adjustable Louvers	363
13.9	Roof Curbs	366
13.10	Translucent Panels	369
13.11	Suspended Ceilings	372

## 14. Insulation

14.1	General	377
14.2	Fiberglass	378
14.3	Rockwool	383
14.4	Double Faced Tape	385
14.5	Patching Tape	386
14.6	Stapler and Staples	387

## 15. Sundry Parts

15.1	General	391
15.2	Anchor Bolts	392
15.3	Primary Connection Bolts	393
15.4	Secondary Connection Bolts	395
15.5	Sheeting Fasteners	396
15.6	Pop Rivets	397
15.7	Foam Closures	398
15.8	Bead Mastic	399
15.9	Flowable Mastic	400
15.10	Pipe Flashing	401

## 16. Special Buyouts

16.1	General	405
16.2	Examples	406

## 17. Specialty Buildings

17.1	General	409
17.2	Vehicle Parking Shelters	410
17.3	Service/Fuel Stations	418
17.4	Poultry Buildings	424
17.5	Bulk Storage Buildings	426
17.6	Aircraft Hangars	429

## 18. Structural Corrosion Protection

18.1	General	437
18.2	Elements of Corrosion Protection	438
18.3	Surface Preparation	442
18.4	Paint Systems	447

## 19. Structural Fire Protection

19.1	General	451
19.2	Passive Fire Protection Systems	452
19.3	Fixed Fire Protection Systems	455
19.4	Fire Detection and Alarm Systems	456

## 20. Foundations

20.1	General	459
20.2	Typical Footing Details	460
20.3	Footing Design	461
20.4	Slab Design	463



## Technical Manual



*A pleasure to do business with*

**ZAMIL STEEL, SAUDI ARABIA**  
**Pre-Engineered Buildings Division**

*January 1999*